

INSTALLATION and OPERATING INSTRUCTIONS for

Display Freezers

Style
ZONE
SERIES



KTB Series



DFR-63 Series



Zero Zone, Inc. • 110 N. Oakridge Dr. • North Prairie, WI 53153-9792
1-800-247-4496 • FAX: 1-414-392-6450 • <http://www.zero-zone.com>

CRMA
Certified

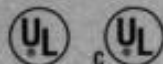

TABLE OF CONTENTS

Subject	
GENERAL INFORMATION	1
INTRODUCTION	1
INSPECTION	1
LOCATION	1
INSTALLATION	1
LEVELING	1
JOINING FREEZERS	1-2
DRAIN LINE	2-3
CART BUMPER	3
REFRIGERATION	3
GENERAL	3
REFRIGERANT PIPING	3
TEMPERATURE CONTROL	4
TEMPERATURE CONTROL ADJUSTMENT	4
LEAK CHECK-EVACUATION-CHARGING	4
ELECTRICAL	4-5
DEFROSTING	5
GENERAL	5
ELECTRIC DEFROST	5
GAS DEFROST	5-6
LIMIT THERMOSTAT	6
USER INFORMATION	6
CLEANING	6
SHELF LOCATION	6
LOADING THE FREEZER	6
LIGHT SWITCH	6
SERVICE	6
CART BUMPER	6-7
EVAPORATOR	7
EXPANSION VALVE	7
DEFROST HEATER ELEMENT	7
SZ HEATER ELEMENT REMOVAL	7
KTB, DFR-63 HEATER ELEMENT REMOVAL	7
EVAPORATOR FANS	7
SZ FAN REMOVAL	7
KTB-DFR-63 FAN REMOVAL	8
LIGHTS	8
BALLASTS	8
ALTERNATE LIGHTING - T8	8

FULL PAGE TABLES

TABLE 1 RI-DFR-SZ/KTB LINE SIZE -14 F R502, R404a, R507 9
 TABLE 2 RI-DFR-SZ/KTB LINE SIZE -20 F R502, R404a, R507 10
 TABLE 3 RI-DFR-SZ/KTB LINE SIZE -14 F R22 11
 TABLE 4 RI-DFR-SZ/KTB LINE SIZE -20 F R22 12
 TABLE 5 RI-DFR-63 LINE SIZE -14 F R502, R404a, R507 13
 TABLE 6 RI-DFR-63 LINE SIZE -20 F R502, R404a, R507 14
 TABLE 7 RI-DFR-63 LINE SIZE -14 F R22 15
 TABLE 8 RI-DFR-63 LINE SIZE -20 F R22 16

FULL PAGE FIGURES

FIGURE 5 KTB SPECIFICATION SHEET 17
 FIGURE 6 SZ SPECIFICATION SHEET 18
 FIGURE 7 DFR-63 SPECIFICATION SHEET 19
 FIGURE 10 SZ/KTB/DFR-63 ELECTRIC DEFROST WIRING DIAGRAM 20
 FIGURE 11 SZ/KTB/DFR-63 HOT GAS DEFROST WIRING DIAGRAM 21
 FIGURE 12 SZ/KTB/DFR-63 WIRING DIAGRAM FOR TIME/TEMPERATURE DEFROST 22
 FIGURE 13 SZ/KTB/DFR-63 ELECTRICAL VALUES 23
 FIGURE 16 SZ ELECTRIC DEFROST ASSEMBLY 24
 FIGURE 17 SZ HOT GAS DEFROST ASSEMBLY 25
 FIGURE 18 KTB/DFR-63 ELECTRIC DEFROST ASSEMBLY 26
 FIGURE 19 KTB/DFR-63 HOT GAS DEFROST 27
 FIGURE 21 SZ/KTB/DFR-63 LIGHT/BALLAST WIRING DIAGRAM 28

WARRANTY 29

GENERAL INFORMATION

Introduction

The information contained in this manual pertains to the following display freezers: RI-DFR-SZ, RI-DFR-KTB, and RI-DFR-63. These are used for merchandising frozen food or ice cream. These display freezers are designed to operate in an air-conditioned store where the temperature is maintained at 75°F or lower and the relative humidity is at 55% or lower.

Inspection

These display freezers were carefully inspected and properly packed to ensure delivery in the best possible condition. The equipment should be uncrated and checked for damage immediately upon delivery. **ALL CLAIMS FOR DAMAGES MUST BE FILED WITH THE TRANSPORTATION COMPANY - NOT WITH ZERO ZONE.** The carrier will supply necessary report and claim forms.

Location

Do not locate this equipment where it will be exposed to the direct rays of the sun or near a source of radiant heat or air flow.

Be certain that the floor under the installation is of sufficient strength to prevent sagging. Out of level conditions will result in reduced performance.

Wall cases, and back to back cases, should be positioned to allow a minimum 2 - 4 inch space behind the back of a unit. This will allow air to circulate behind the unit.

INSTALLATION

Leveling (See Figure 1)

Refrigeration equipment must be installed level to allow efficient operation of the refrigeration coils and complete drainage of defrost water. Since a level area is seldom available, the following steps are recommended to insure a level installation.

1. Measure off and mark on floor the exact dimensions of the case line-up. (Check blueprints).
2. Snap a chalk line at the locations for the front and back positions of the base rails.

3. Mark locations of all joints (front and back).

4. Using a transit, find the highest point along both base rail position lines. Using the high point as a reference, mark the difference directly on the floor at each joint (front and back).

5. If a transit is not available, a water level can be used to mark reference elevation points. Water levels can be purchased from a contractor supply house for a minimal cost.

6. A string level can also be used to mark elevation points. The string level should only be used on short line-ups to avoid string sag.

7. Place the required number of shims (supplied) at each joint (front and back) to equal the highest point. Tape all shims in place.

8. Place additional support shims at the center of four and five door case base rails (front and back).

9. Use a carpenter's level to check installation as you go. The case should be level from front to back and side to side. Install the case at the highest point first if part of a line-up.

Joining Freezers

These Reach-Ins have been engineered for continuous display. This means that any number of Reach-In freezers can be joined together to create a display of any desired length. Reach-In freezers are built on permanent steel skids to promote easy installation. The case can be moved on pipe rollers or with a Johnson Bar. The ends of the case are protected with a removable steel plate.

To install Reach-Ins, perform the following steps.

1. Set the first Reach-In into the desired position and level it. Run a 3/8 inch diameter bead of Butyl caulk 1/2 inch in from both the inner and outer surfaces of the case end. (See Figure 2)
2. Push the second Reach-In against the end of the first. Level the second Reach-In. Remove the left and right end coil covers and the rectangular pocket hole covers, accessing the holes in the end panels of each freezer as shown. (See Figure 3).
3. Start the joining bolts, but do not tighten them. Begin tightening the bolts at the top rear, working down the back of the case and up the front making sure that the front seams are flush.

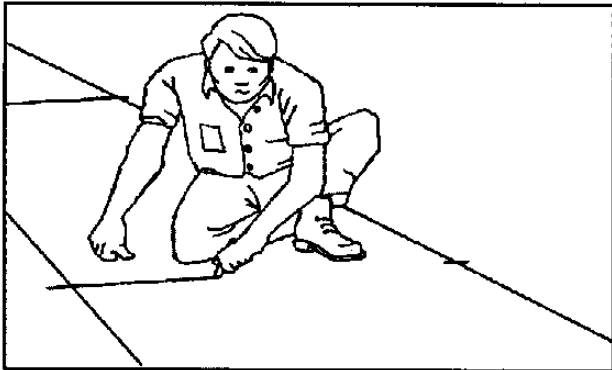

Measure and mark exact case outline

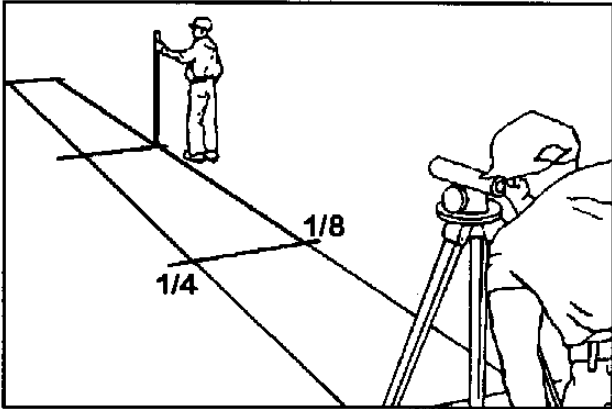

Mark floor level differences

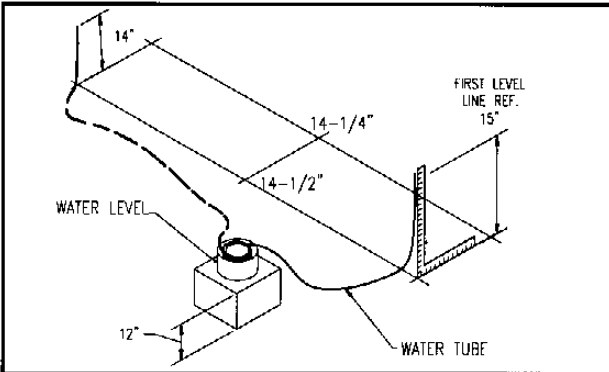

Water level elevation points

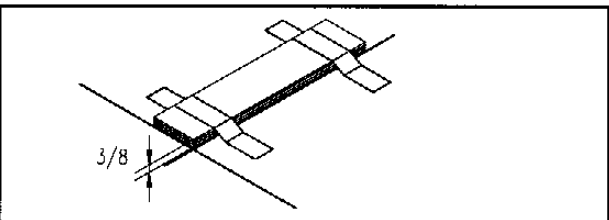

Shim joints to equal highest points

Figure 1: Leveling cases prior to joining

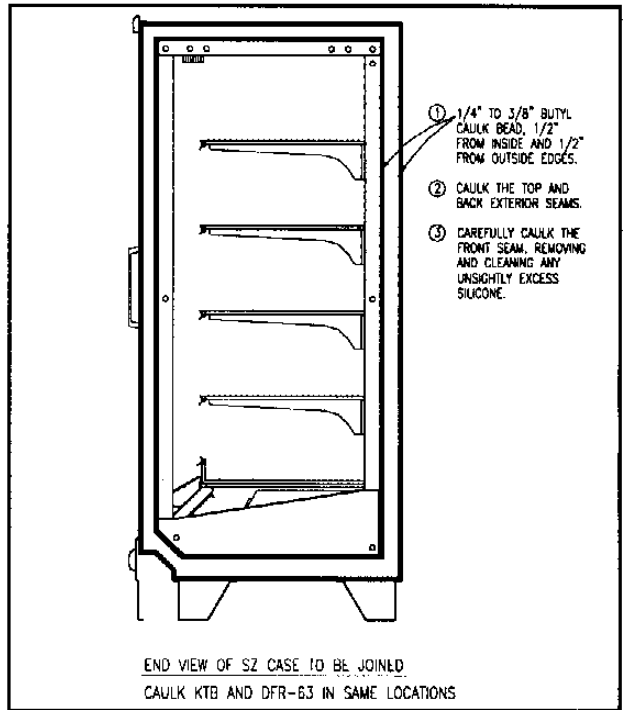

Figure 2: Caulking cases to be joined

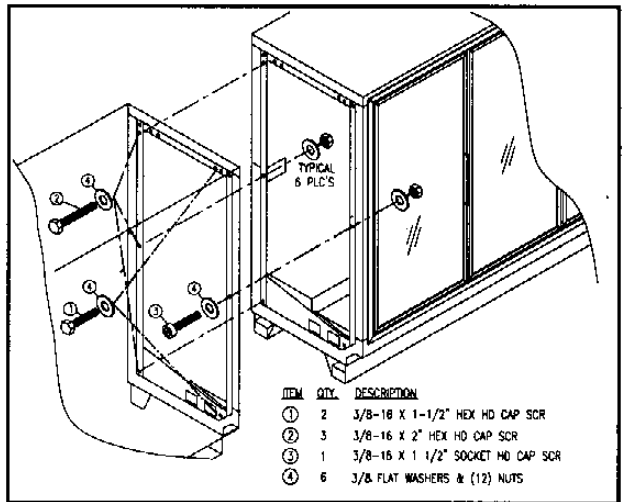

Figure 3 Joining Reach-In Freezers

Drain Line

The drain is located at the center of the freezer in the floor pan. On 3 and 5 door SZ cases, it can be reached by removing the center insulated coil cover.

On 2 and 4 door SZ cases, it can be reached by removing the left of center insulated coil cover. A plastic access cover can then be removed from the fan housing. On KTB and DFR-63 cases, a small center cover can be removed to access the drain. The 1 inch PVC drain outlet is located at the center front of the freezer behind the kick plate.

Install a tee to the outlet pipe and a PVC drain trap to the tee. Plug the open end of the tee using the clean-out plug supplied with the drain trap kit. The drain line must be pitched away from the case a minimum of 1/4 inch per foot. The tee, drain trap, and plug are supplied standard with the case.

Cart Bumper

The cart bumper should be installed at the bottom front of the case. (See Figure 4) The assembly is adjustable to compensate for uneven floors.

Center and hook the bumper assembly on the hangers provided.

In continuous line-ups, place a kick plate joint strip at each joint. On case ends, line-up an end kick plate with the front mounting holes. Fasten the rear of the end kick plate to the case using tech screws.

Slide the front kick plate behind the bumper assembly and in front of the end kick plate or kick plate joint strip. Install three screws (two screws on two door only) to hold the kick plate and bumper in place.

A bumper joint strip can be installed over the bumper

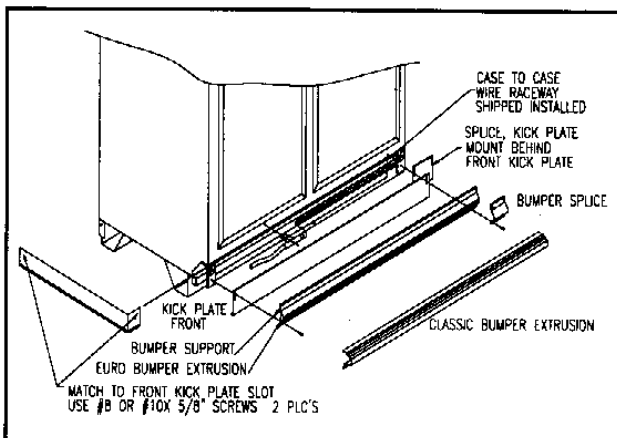

Figure 4: Case Bumper Assembly

at the joints. This is standard on Euro Style Trim and optional on Classic Style Trim.

REFRIGERATION

General

Unless otherwise specified, the liquid and suction connections are made inside the case under the evaporator fan cover on the left side of the freezer. Refrigerant piping enters the case through the front bottom. (See Figure 5, 6, and 7) Alternate locations are out the back of case or left rear top of case. After connections have been made, the refrigeration access hole in the freezer must be sealed completely with aerosol-dispensed Urethane insulation or equivalent.

Refrigerant Piping

Correct refrigeration line sizing and installation is essential for proper system operation. The following tables (Tables 1 through 8) list R502, R404A, R507, and R-22 line sizes for different combinations of frozen food and ice cream freezers. A P-trap must be installed at the bottom of all vertical suction risers.

When two or more freezer sections are connected to one compressor, the main liquid and suction line for the group should be run through the freezers under the fan housing and brought out through the refrigeration outlet of one freezer only.

The compressor should be installed as close as possible to the freezers to reduce pressure drop. If the compressor is located above the freezer, use one size smaller tube for the suction tube riser only and install a shallow trap at the bottom of the riser. Use a flexible connection (vibration eliminator) between the suction line and compressor.

The suction and liquid lines may be taped together to form an external heat exchanger. Insulate the tubing for at least 20 feet from the freezer outlet.

The best location for the liquid line drier is inside the freezing compartment. However, it may be installed near the compressor for easy maintenance. Install a moisture indicating sight glass at the outlet end of the drier.

Temperature Control

A low pressure or temperature control can be used to control freezer temperature. The control should be selected with adequate contact capacity for the switching load. In rack systems, an evaporator pressure regulating valve may be used to control the evaporating temperature.

	Frozen Food				
	Pressure (psig)				RETURN AIR Temp.
	R-22	R502	R404A	R507	
Cut In	22	28	30	35	0°F
Cut Out	10	15	16	18	-6°F
	Ice Cream				
	Pressure (psig)				RETURN AIR Temp.
	R-22	R-502	R404A	R507	
Cut In	22	28	30	32	-6°F
Cut Out	8	12	13	14	-12°F

Figure 8

The settings (See Figure 8) are approximate due to variations in gauge accuracy, differences in compressor efficiency, and line pressure drop. These should be adjusted as store or stocking conditions change.

Temperature Control Adjustment

When factory installed, the temperature control is located toward the right end of the freezer behind the black kick plate. The sensing bulb is located under the coil cover inside the cabinet. It should be wired in place of the low pressure (L.P.) control. The wiring diagram shows use of the thermostat in a pump down system. See applicable wiring diagrams. (Figure 9 shows a typical temperature control.)

Leak Check-Evacuation-Charging

After all of the refrigeration piping and system components have been assembled, the entire system must be pressurized and checked for leaks. Use nitrogen and refrigerant vapor to check for leaks. A Halide leak detector or an electronic leak detector is recommended.

If the system is sealed, evacuate with a high vacuum pump. Triple evacuation to a minimum of 500 microns

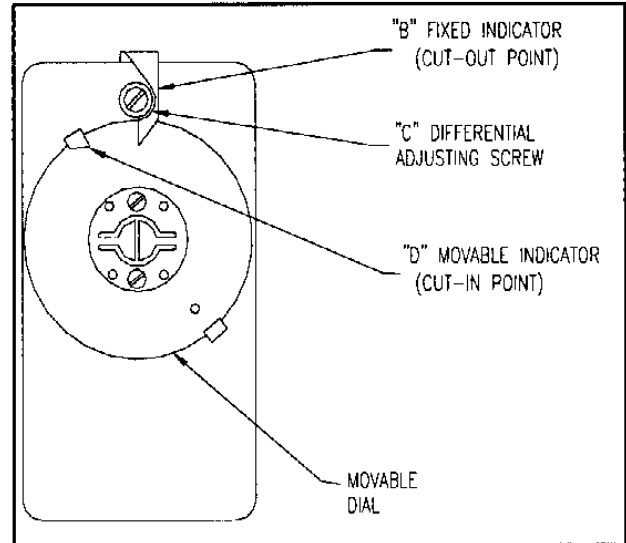

Figure 9: Typical Temperature Control

and nitrogen sweep is recommended. After the system has been thoroughly evacuated of all moisture and non-condensable gas, charge the system with the proper refrigerant, using "hi-side/low-side" charging techniques.

ELECTRICAL

Figure 10 shows the typical wiring diagram for a freezer equipped with electric defrost. Figure 11 shows the typical wiring diagram for a freezer equipped with hot gas defrost. Each case is provided with a wiring diagram located in the electric box that shows the exact wiring of the case.

Figure 12 shows the typical wiring of one case with the standard temperature terminating defrost control. The defrost heaters will de-energize when the defrost termination control has been satisfied.

There are many control options available for multiple case defrost systems. Wiring diagrams and instructions can be obtained by calling Zero Zone's Service Department.

External wiring should be sized according to the amperage rating stamped on the serial plate. The serial plate is located on the ceiling inside the left hand door. Typical electrical values are shown in Figure 13. All internal wiring has been done at the

factory, and has been terminated in the electrical compartment located behind the kick rail at the right end of the case.

A terminal block has been used to simplify field connections. The terminal block, an insulation displacement type, features an internal self-stripping wire mechanism. The cutting blades eliminate the need for manual wire stripping on the pre-wired side of the block. A wire can only be inserted in the block two times before the cutting blades become dull. Wire insertion tools can be purchase from the factory, or a small screw driver can be used. The customer's side of the block utilizes a screw clamp connection to accommodate multiple wire insertions. See Figure 14 for standard wire size range per terminal block.

The 115 volt circuits in the freezer are energized at all times except during defrost. The 220 volt defrost element is OFF at all times except during defrost. The time clock is in operation at all times.

TERMINAL BLOCK WIRE SIZE SPECIFICATIONS		
TERMINAL BLOCK DESCRIPTION	CURRENT RATING (AMP)	CUSTOMER WIRE SIZE
SELF-STRIPPING 6MM (1/4")	18A	22-12 AWG.
SELF-STRIPPING 8MM (5/16")	25A	22-8 AWG.
COMPRESSION CLAMP 8MM (5/16")	50A	22-8 AWG.

Figure 14: Terminal Block Chart

Note: All wiring must comply with the National Electrical Code and all local codes.

DEFROSTING

General

Periodic defrosting to keep the coil free of frost is accomplished automatically by a time clock used in conjunction with an electric, hot gas, or reduced temperature gas injection defrost system. The most reliable and efficient defrost system for a single case uses a time clock that incorporates a defrost termination device. Time clocks can be purchased that terminate on coil temperature or case coil pressure. These clocks have the ability to match the defrost time to the frost load on the coil. Coil temperature is sensed by the defrost termination thermostat supplied

as standard on all Zero Zone freezers. Pressure terminating clocks generally have the pressure switch built into the time clock. A time clock can be purchased from Zero Zone or from a local refrigeration supply house.

Electric Defrost

When the pin in the 24 hour dial reaches the TIME arrow, the clock will trip and the defrost cycle will start. At that time, the clock will stop the compressor, energize the 220 volt defrost heater, and energize the normally closed 220 volt contactor. This de-energizes the 115 volt fans, lights, and anti-sweat heaters.

After the defrost period, the compressor will operate. When the coil temperature reaches +5°F, the fan, light and anti-sweat heater limit thermostats will close, starting the fans, lights and anti-sweat heaters.

Gas Defrost

Several types of gas defrost methods in conjunction with time actuated, time or temperature terminated defrost timers can be used to defrost the evaporator.

The refrigeration system designer and installer are responsible for correct line sizing for effective gas defrost and liquid return from the freezers. Sizing and component selection depend on the type of defrost, size, and location of high side refrigeration system.

Zero Zone freezers equipped for gas defrost consist of a side port, distributor and check valve for coil defrost, and a check valve and serpentine coil attached to the bottom of the pan to ensure pan and drain defrost.

Liquid and suction line connections are made inside the case, through the refrigeration access hole located in the floor pan on the left side of the freezer.

The timer starts the gas defrost cycle by energizing a solenoid, reversing valve, or directional valve. The gas is injected from the source into the suction line of the evaporator to be defrosted. The gas flows into the serpentine coil attached to the floor of the case and into the evaporator. Condensed liquid leaves the evaporator through the side port distributor, through a check valve into the liquid line. Liquid condensed in the serpentine passes through a check valve into the liquid line. (See Figure 17 & 19).

Refer to the defrost frequency and termination rec-

TEMPERATURE/PRESSURE TERMINATION			
	Reduced Temp. Gas Defrost	Hot Gas	Electric
Frequency	1	1	1
Temp.(°F)**	50	50	50
Pressure	Saturated Suction Pressure Equal to 50 ° F.		
Fail Safe			
Time (Min.)	40	30	60
Drain			
Time (Min.)	0-3	0-3	0
TIME ONLY TERMINATION			
Time (Min.)	14-22 min.	12-20 min.	45-50 min.
Drain Time	0-3	0-3	0

ommendations that follow.

Figure 15: Defrost Frequency and Termination

* Refrigeration technician should recheck coil condition after one week of operation to be certain that the frequency and duration of defrost is adequate for the particular store and locality.

** Temperature termination thermostats should be wired in series for multiple evaporator installations.

Limit Thermostat

Each freezer has factory set limit thermostats attached to the return bends of the coil on the right end of the freezer to regulate the operation of the evaporator fans, freezer lights, and anti-sweat heaters.

OPERATION OF THE LIMIT THERMOSTATS CAUSES THE EVAPORATOR FANS, FREEZER LIGHTS, AND ANTI-SWEAT HEATERS TO REMAIN OFF UNTIL THE COMPRESSOR IS OPERATING AND THE COIL TEMPERATURE IS BROUGHT BELOW THE THERMOSTAT CUT-IN SETTING (+5°F).

When the freezer first operates, the fans and lights may cycle off and on a few times until coil temperature is below +5°F.

USER INFORMATION

Cleaning

The freezer should be thoroughly cleaned before start-up and routinely thereafter to maintain a clean appearance. Use a mild detergent and warm water (never an abrasive cleaner) to wipe out the inside of the freezer. Wash down all glass doors with glass cleaner. The freezer will remain bright and sparkling with just a few minutes of cleaning each week. The case drain should be regularly cleared of debris and price tags.

Note: Do not use high pressure water or steam to clean the interior.

Shelf Location

The shelves are adjustable in 1 inch increments on SZ cases and 1/2 inch increments on KTB and DFR-63 cases and may be located in any position for best display advantage. Due to the air discharge arrangement, it is suggested that the uppermost shelf be placed 11 inches down from the ceiling. Place the remaining shelves approximately 10 1/2 inches apart.

Be sure shelf clips or brackets are completely seated before installing the shelf.

Loading the Freezer

The freezer may be loaded with merchandise after it has been operated for at least 24 hours with correct case temperature and proper control operation. While loading the shelves, leave at least 1 1/2 inch between the top of the merchandise and the shelf above it so the customer can remove the merchandise. The 1 1/2 inch space allows an air curtain on the top of the product.

For proper display, the products should be placed on edge and slanted to the back so the customer sees the face of the packages. Rotate inventory on a regular basis.

Light Switch

The light switch is located inside the freezer in the upper right corner of the door frame. Turn the light switch off during the initial freezer temperature pull-down to prevent the freezer lights from cycling off and on. Always turn the lights off when replacing lamps.

SERVICE

See Figures 16 and 17 for the typical component layout of the SZ case. See Figures 18, and 19 for the typical component layout of the KTB and DFR-63 cases.

Cart Bumper

The cart bumper must be removed to gain access to the drain connection, electrical connection, and refrigeration outlet sleeve. Disassemble the bumper and black kick rail by removing the 2 or 3 metal screws located in the kick rail. The bumper assembly

can be lifted up and removed from the case. The kick plate can be removed, exposing the electrical connection and refrigeration outlet. (Figure 4 shows the bumper assembly)

Evaporator

The evaporator coil, located at the rear bottom of the freezer, is factory assembled with distributor, expansion valve, and heat exchanger. To inspect the SZ coil, remove the center or left of center - insulated coil cover. A small inspection port is located at the rear of the case. To inspect the entire SZ coil remove the remaining insulated coil covers. Pull the top edge of the fan housing forward and then raise the coil cover.

The coil on KTB and DFR-63 cases is accessed by removing the screws from the coil cover. The cover can be raised by rotating it at the rear integral hinge.

Expansion Valve

Unless otherwise specified, an externally equalized thermostatic expansion valve with pressure limiting ZP charge, adjustable super-heat, and thermal bulb is mounted to the evaporator coil. Under certain conditions, it may be necessary to adjust the super-heat setting for maximum coil effectiveness. Typical super heat settings are between 6°F and 12°F. To adjust the expansion valve, remove the right end insulated coil cover. Remove the cap from the bottom of the valve. When looking at the valve stem end, turn the valve stem counterclockwise to decrease super heat. Turn the valve stem clockwise to increase super heat. Measure the suction line temperature at the expansion valve sensing bulb and compare it to the suction temperature corresponding to the saturated pressure. Make sure that line pressure drop is taken into account.

Turn the valve stem only 1/4 turn at a time and allow sufficient time (20 to 30 minutes) for the valve to settle before making any further adjustments. Replace the valve stem cap after the valve super-heat has been adjusted. **BE CERTAIN THE VALVE STEM CAP IS WIPED DRY FIRST.**

! CAUTION !
DISCONNECT POWER TO THE CASE BEFORE
SERVICING ELECTRICAL COMPONENTS

Defrost Heater Element

The heater element is located under the coil. The electric wire leads are connected in the junction box behind the front kick rail.

SZ Heater Element Removal

To remove the defrost element, remove the insulated coil covers. Next, tip the fan housing forward and lift the inner coil cover upward. This will expose the coil. Remove both of the fan housing end brackets, then slide out the complete heater pan assembly from under the coil. Slowly lift the heater pan assembly between the coil and fan housing, turning it on edge while lifting.

KTB, DFR-63 Heater Element Removal

To remove the defrost element, remove the right, left, and center coil covers. Next, remove the fan housing legs and air baffle assembly fastened to the rear edge of the fan housing with sheet metal screws. Turn the metal clips holding the heater pan from both ends of the coil end plates so they disengage the heater pan. Then slide out the complete heater pan assembly from under the coil and under the fan housing. Slowly lift the heater pan assembly between coil and fan housing, turning it in edge while lifting.

Evaporator Fans

Air is circulated throughout the freezer with 115 volt low temperature shaft up fan motors. These motors must be operating at all times except during defrost. To service the fan:

SZ Fan Removal

1. Turn off power to fans.
2. Remove insulated coil cover.
3. Unplug fan from fan power supply plug located on the front face of the fan housing.
4. Remove the two mounting bolts and remove the fan assembly from the fan housing.

KTB - DFR-63 Fan Removal

1. Turn off power to fans.
2. Remove wire fan guard.
3. Remove fan motor mounting bracket screws.
4. Set motor fan assembly on floor of case.
5. Unplug power supply plug.
6. Lift and rotate motor fan assembly from case.

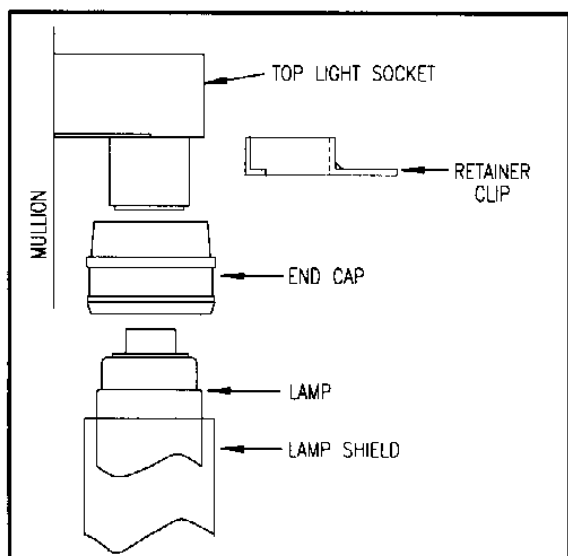

Figure 20: Socket detail

Lights

Very high output 1500 milliamp lamps are standard with KTB and DFR-63 freezers and optional on SZ freezers. To ensure maximum component life, always replace with 1500 milliamp lamps. Use retainer clips and lamp shields.

To change a lamp, turn off the light switch and remove the retainer clip located between the top socket and end cap. Carefully push the lamp up into the spring-loaded lamp socket to allow the lamp to be removed from the bottom socket. (See Figure 20.) Remove the end caps and shield. All lamps must use end caps and shields.

Ballast

Zero Zone freezer ballasts are located either behind the kick plate or in the door mullions. Figure 21 shows which ballast is connected to which lamp when the ballasts are located behind the kick plate.

Alternate Lighting -T8

T-8 lighting is standard on the SZ case and optional on the KTB and DFR-63 freezers. Many door manufacturers provide premium lighting systems. These systems use a lens to direct light output evenly across the shelves. The lamp used is a Osram FO40W/41K (5ft). The lens must be removed to access the lamp. The lamp may be removed by turning it 90 degrees and sliding the lamp pins out of the lamp socket slot. The jacket must be installed over the lamp. Detailed information is contained in the door instruction booklet.

Table 1

ZERO ZONE

REMOTE REACH-IN FREEZER W/ 30" X 63" DOORS
MODEL RI-DFR-SZ/KTB
REFRIGERANT R-502, R-404a, R-507 @ -14 °F
EVAPORATOR FOR FROZEN FOOD

NO. OF DOORS	FREEZER COMBINATIONS	TOTAL LENGTH W/ENDS	BTU/HR	RECOMMENDED LIQUID LINE SIZES EQUIVALENT LENGTH, FEET			RECOMMENDED SUCTION LINE SIZES EQUIVALENT LENGTH, FEET		
				50	100	150	50	100	150
2	(1) 2-DR	5'-9"	3720	3/8	3/8	3/8	7/8	7/8	7/8
3	(1) 3-DR	8'-3 1/2"	4990	3/8	3/8	3/8	7/8	7/8	7/8
4	(1) 4-DR	10'-11"	6265	3/8	3/8	3/8	7/8	7/8	7/8
5	(1) 5-DR	13'-6 1/2"	7575	3/8	3/8	3/8	7/8	7/8	7/8
6	(2) 3-DR	16'-2"	9090	3/8	3/8	3/8	7/8	7/8	1 1/8
7	(1) 3-DR & (1) 4-DR	18'-9 1/2"	10605	3/8	1/2	1/2	7/8	1 1/8	1 1/8
8	(2) 4-DR	21'-5"	12120	3/8	1/2	1/2	1 1/8	1 1/8	1 1/8
9	(1) 4-DR & (1) 5-DR	24'-1/2"	13635	3/8	1/2	1/2	1 1/8	1 1/8	1 1/8
10	(2) 5-DR	26'-8"	15150	3/8	1/2	1/2	1 1/8	1 1/8	1 1/8
11	(1) 3-DR & (2) 4-DR	29'-3 1/2"	16665	1/2	1/2	1/2	1 1/8	1 3/8	1 3/8
12	(3) 4-DR	31'-11"	18180	1/2	1/2	1/2	1 1/8	1 3/8	1 3/8
13	(2) 4-DR & (1) 5-DR	34'-6 1/2"	19695	1/2	1/2	1/2	1 1/8	1 3/8	1 3/8
14	(1) 4-DR & (2) 5-DR	37'-2"	21210	1/2	1/2	1/2	1 1/8	1 3/8	1 3/8
15	(3) 5-DR	39'-9 1/2"	22725	1/2	5/8	5/8	1 1/8	1 3/8	1 3/8
16	(4) 4-DR	42'-5"	24240	1/2	5/8	5/8	1 1/8	1 3/8	1 3/8
17	(3) 4-DR & (1) 5-DR	45'-1/2"	25755	1/2	5/8	5/8	1 1/8	1 3/8	1 3/8
18	(2) 4-DR & (2) 5-DR	47'-8"	27270	1/2	5/8	5/8	1 1/8	1 3/8	1 3/8
19	(1) 4-DR & (3) 5-DR	50'-3 1/2"	28785	1/2	5/8	5/8	1 3/8	1 3/8	1 3/8
20	(4) 5-DR	52'-11"	30300	1/2	5/8	5/8	1 3/8	1 3/8	1 5/8
21	(4) 4-DR & (1) 5-DR	55'-6 1/2"	31815	1/2	5/8	5/8	1 3/8	1 3/8	1 5/8
22	(3) 4-DR & (2) 5-DR	58'-2"	33330	1/2	5/8	5/8	1 3/8	1 5/8	1 5/8
23	(2) 4-DR & (3) 5-DR	60'-9 1/2"	34845	1/2	5/8	5/8	1 3/8	1 5/8	1 5/8
24	(1) 4-DR & (4) 5-DR	63'-5"	36360	1/2	5/8	5/8	1 3/8	1 5/8	1 5/8
25	(5) 5-DR	66'-1/2"	37875	1/2	5/8	5/8	1 3/8	1 5/8	1 5/8
26	(4) 4-DR & (2) 5-DR	68'-8"	39390	1/2	5/8	5/8	1 3/8	1 5/8	1 5/8
27	(3) 4-DR & (3) 5-DR	71'-3 1/2"	40905	1/2	5/8	5/8	1 3/8	1 5/8	1 5/8
28	(2) 4-DR & (4) 5-DR	73'-11"	42420	1/2	5/8	5/8	1 3/8	1 5/8	1 5/8
29	(1) 4-DR & (5) 5-DR	76'-6 1/2"	43935	5/8	5/8	5/8	1 3/8	1 5/8	1 5/8
30	(6) 5-DR	79'-2"	45450	5/8	5/8	5/8	1 3/8	1 5/8	1 5/8

BTU/HR RATING BASED ON 1500 mA T-10 LIGHTING. CASE DESIGNED TO OPERATE IN AN AMBIENT OF 75 °F OR LOWER AND RELATIVE HUMIDITY OF 55% OR LOWER

REMOTE REACH-IN FREEZER W/ 30" X 63" DOORS
MODEL RI-DFR-SZ/KTB
REFRIGERANT R-502, R-404a, R-507 @ -20 °F
EVAPORATOR FOR ICE CREAM

NO. OF DOORS	FREEZER COMBINATIONS	TOTAL LENGTH W/ENDS	BTU/HR	RECOMMENDED LIQUID LINE SIZES EQUIVALENT LENGTH, FEET			RECOMMENDED SUCTION LINE SIZES EQUIVALENT LENGTH, FEET		
				50	100	150	50	100	150
2	(1) 2-DR	5'-9"	4000	3/8	3/8	3/8	7/8	7/8	7/8
3	(1) 3-DR	8'-3 1/2"	5355	3/8	3/8	3/8	7/8	7/8	7/8
4	(1) 4-DR	10'-11"	6720	3/8	3/8	3/8	7/8	7/8	1 1/8
5	(1) 5-DR	13'-6 1/2"	8125	3/8	3/8	3/8	7/8	7/8	1 1/8
6	(2) 3-DR	16'-2"	9750	3/8	3/8	3/8	7/8	1 1/8	1 1/8
7	(1) 3-DR & (1) 4-DR	18'-9 1/2"	11375	3/8	1/2	1/2	1 1/8	1 1/8	1 1/8
8	(2) 4-DR	21'-5"	13000	3/8	1/2	1/2	1 1/8	1 1/8	1 3/8
9	(1) 4-DR & (1) 5-DR	24'-1/2"	14625	3/8	1/2	1/2	1 1/8	1 1/8	1 3/8
10	(2) 5-DR	26'-8"	16250	3/8	1/2	1/2	1 1/8	1 3/8	1 3/8
11	(1) 3-DR & (2) 4-DR	29'-3 1/2"	17875	1/2	1/2	1/2	1 1/8	1 3/8	1 3/8
12	(3) 4-DR	31'-11"	19500	1/2	1/2	1/2	1 1/8	1 3/8	1 3/8
13	(2) 4-DR & (1) 5-DR	34'-6 1/2"	21125	1/2	1/2	1/2	1 1/8	1 3/8	1 3/8
14	(1) 4-DR & (2) 5-DR	37'-2"	22750	1/2	5/8	5/8	1 3/8	1 3/8	1 3/8
15	(3) 5-DR	39'-9 1/2"	24375	1/2	5/8	5/8	1 3/8	1 3/8	1 5/8
16	(4) 4-DR	42'-5"	26000	1/2	5/8	5/8	1 3/8	1 3/8	1 5/8
17	(3) 4-DR & (1) 5-DR	45'-1/2"	27625	1/2	5/8	5/8	1 3/8	1 3/8	1 5/8
18	(2) 4-DR & (2) 5-DR	47'-8"	29250	1/2	5/8	5/8	1 3/8	1 5/8	1 5/8
19	(1) 4-DR & (3) 5-DR	50'-3 1/2"	30875	1/2	5/8	5/8	1 3/8	1 5/8	1 5/8
20	(4) 5-DR	52'-11"	32500	1/2	5/8	5/8	1 3/8	1 5/8	1 5/8
21	(4) 4-DR & (1) 5-DR	55'-6 1/2"	34125	1/2	5/8	5/8	1 3/8	1 5/8	1 5/8
22	(3) 4-DR & (2) 5-DR	58'-2"	35750	1/2	5/8	5/8	1 3/8	1 5/8	1 5/8
23	(2) 4-DR & (3) 5-DR	60'-9 1/2"	37375	1/2	5/8	5/8	1 3/8	1 5/8	2 1/8
24	(1) 4-DR & (4) 5-DR	63'-5"	39000	1/2	5/8	5/8	1 3/8	1 5/8	2 1/8
25	(5) 5-DR	66'-1/2"	40625	1/2	5/8	5/8	1 3/8	1 5/8	2 1/8
26	(4) 4-DR & (2) 5-DR	68'-8"	42250	5/8	5/8	5/8	1 5/8	1 5/8	2 1/8
27	(3) 4-DR & (3) 5-DR	71'-3 1/2"	43875	5/8	5/8	5/8	1 5/8	1 5/8	2 1/8
28	(2) 4-DR & (4) 5-DR	73'-11"	45500	5/8	5/8	5/8	1 5/8	2 1/8	2 1/8
29	(1) 4-DR & (5) 5-DR	76'-6 1/2"	47125	5/8	5/8	5/8	1 5/8	2 1/8	2 1/8
30	(6) 5-DR	79'-2"	48750	5/8	5/8	5/8	1 5/8	2 1/8	2 1/8

BTU/HR RATING BASED ON 1500 ma T-10 LIGHTING. CASE DESIGNED TO OPERATE IN AN AMBIENT OF 75 °F OR LOWER AND RELATIVE HUMIDITY OF 55% OR LOWER

Table 3



REMOTE REACH-IN FREEZER W/ 30" X 63" DOORS
MODEL RI-DFR-SZ/KTB
REFRIGERANT R-22 @ -14 °F
EVAPORATOR FOR FROZEN FOOD

NO. OF DOORS	FREEZER COMBINATIONS	TOTAL LENGTH W/ENDS	BTU/HR	RECOMMENDED LIQUID LINE SIZES EQUIVALENT LENGTH, FEET			RECOMMENDED SUCTION LINE SIZES EQUIVALENT LENGTH, FEET		
				50	100	150	50	100	150
2	(1) 2-DR	5'-9"	3720	3/8	3/8	3/8	5/8	7/8	7/8
3	(1) 3-DR	8'-3 1/2"	4990	3/8	3/8	3/8	7/8	7/8	7/8
4	(1) 4-DR	10'-11"	6265	3/8	3/8	3/8	7/8	7/8	7/8
5	(1) 5-DR	13'-6 1/2"	7575	3/8	3/8	3/8	7/8	7/8	7/8
6	(2) 3-DR	16'-2"	9090	3/8	3/8	3/8	7/8	7/8	1 1/8
7	(1) 3-DR & (1) 4-DR	18'-9 1/2"	10605	3/8	3/8	1/2	7/8	1 1/8	1 1/8
8	(2) 4-DR	21'-5"	12120	3/8	3/8	1/2	7/8	1 1/8	1 1/8
9	(1) 4-DR & (1) 5-DR	24'-1/2"	13635	3/8	1/2	1/2	7/8	1 1/8	1 1/8
10	(2) 5-DR	26'-8"	15150	3/8	1/2	1/2	7/8	1 1/8	1 1/8
11	(1) 3-DR & (2) 4-DR	29'-3 1/2"	16665	3/8	1/2	1/2	7/8	1 1/8	1 1/8
12	(3) 4-DR	31'-11"	18180	1/2	1/2	1/2	1 1/8	1 1/8	1 3/8
13	(2) 4-DR & (1) 5-DR	34'-6 1/2"	19695	1/2	1/2	1/2	1 1/8	1 1/8	1 3/8
14	(1) 4-DR & (2) 5-DR	37'-2"	21210	1/2	1/2	1/2	1 1/8	1 3/8	1 3/8
15	(3) 5-DR	39'-9 1/2"	22725	1/2	1/2	1/2	1 1/8	1 3/8	1 3/8
16	(4) 4-DR	42'-5"	24240	1/2	1/2	1/2	1 1/8	1 3/8	1 3/8
17	(3) 4-DR & (1) 5-DR	45'-1/2"	25755	1/2	1/2	1/2	1 1/8	1 3/8	1 3/8
18	(2) 4-DR & (2) 5-DR	47'-8"	27270	1/2	1/2	1/2	1 1/8	1 3/8	1 3/8
19	(1) 4-DR & (3) 5-DR	50'-3 1/2"	28785	1/2	1/2	1/2	1 1/8	1 3/8	1 3/8
20	(4) 5-DR	52'-11"	30300	1/2	1/2	1/2	1 3/8	1 3/8	1 5/8
21	(4) 4-DR & (1) 5-DR	55'-6 1/2"	31815	1/2	1/2	5/8	1 3/8	1 3/8	1 5/8
22	(3) 4-DR & (2) 5-DR	58'-2"	33330	1/2	1/2	5/8	1 3/8	1 3/8	1 5/8
23	(2) 4-DR & (3) 5-DR	60'-9 1/2"	34845	1/2	1/2	5/8	1 3/8	1 3/8	1 5/8
24	(1) 4-DR & (4) 5-DR	63'-5"	36360	1/2	5/8	5/8	1 3/8	1 5/8	1 5/8
25	(5) 5-DR	66'-1/2"	37875	1/2	5/8	5/8	1 3/8	1 5/8	1 5/8
26	(4) 4-DR & (2) 5-DR	68'-8"	39390	1/2	5/8	5/8	1 3/8	1 5/8	1 5/8
27	(3) 4-DR & (3) 5-DR	71'-3 1/2"	40905	1/2	5/8	5/8	1 3/8	1 5/8	1 5/8
28	(2) 4-DR & (4) 5-DR	73'-11"	42420	1/2	5/8	5/8	1 3/8	1 5/8	1 5/8
29	(1) 4-DR & (5) 5-DR	76'-6 1/2"	43935	1/2	5/8	5/8	1 3/8	1 5/8	1 5/8
30	(6) 5-DR	79'-2"	45450	1/2	5/8	5/8	1 3/8	1 5/8	1 5/8

BTU/HR RATING BASED ON 1500 ma T-10 LIGHTING. CASE DESIGNED TO OPERATE IN AN AMBIENT OF 75 °F OR LOWER AND RELATIVE HUMIDITY OF 55% OR LOWER



Table 4

REMOTE REACH-IN FREEZER W/ 30" X 63" DOORS
MODEL RI-DFR-SZ/KTB
REFRIGERANT R-22 @ -20 °F
EVAPORATOR FOR ICE CREAM

NO. OF DOORS	FREEZER COMBINATIONS	TOTAL LENGTH W/ENDS	BTU/HR	RECOMMENDED LIQUID LINE SIZES EQUIVALENT LENGTH, FEET			RECOMMENDED SUCTION LINE SIZES EQUIVALENT LENGTH, FEET		
				50	100	150	50	100	150
2	(1) 2-DR	5'-9"	4000	3/8	3/8	3/8	5/8	7/8	7/8
3	(1) 3-DR	8'-3 1/2"	5355	3/8	3/8	3/8	7/8	7/8	7/8
4	(1) 4-DR	10'-11"	6720	3/8	3/8	3/8	7/8	7/8	7/8
5	(1) 5-DR	13'-6 1/2"	8125	3/8	3/8	3/8	7/8	7/8	1 1/8
6	(2) 3-DR	16'-2"	9750	3/8	3/8	3/8	7/8	1 1/8	1 1/8
7	(1) 3-DR & (1) 4-DR	18'-9 1/2"	11375	3/8	3/8	1/2	7/8	1 1/8	1 1/8
8	(2) 4-DR	21'-5"	13000	3/8	3/8	1/2	7/8	1 1/8	1 1/8
9	(1) 4-DR & (1) 5-DR	24'-1/2"	14625	3/8	1/2	1/2	1 1/8	1 1/8	1 1/8
10	(2) 5-DR	26'-8"	16250	3/8	1/2	1/2	1 1/8	1 1/8	1 3/8
11	(1) 3-DR & (2) 4-DR	29'-3 1/2"	17875	3/8	1/2	1/2	1 1/8	1 1/8	1 3/8
12	(3) 4-DR	31'-11"	19500	1/2	1/2	1/2	1 1/8	1 3/8	1 3/8
13	(2) 4-DR & (1) 5-DR	34'-6 1/2"	21125	1/2	1/2	1/2	1 1/8	1 3/8	1 3/8
14	(1) 4-DR & (2) 5-DR	37'-2"	22750	1/2	1/2	1/2	1 1/8	1 3/8	1 3/8
15	(3) 5-DR	39'-9 1/2"	24375	1/2	1/2	1/2	1 1/8	1 3/8	1 3/8
16	(4) 4-DR	42'-5"	26000	1/2	1/2	1/2	1 1/8	1 3/8	1 3/8
17	(3) 4-DR & (1) 5-DR	45'-1/2"	27625	1/2	1/2	1/2	1 1/8	1 3/8	1 3/8
18	(2) 4-DR & (2) 5-DR	47'-8"	29250	1/2	1/2	1/2	1 3/8	1 3/8	1 5/8
19	(1) 4-DR & (3) 5-DR	50'-3 1/2"	30875	1/2	1/2	1/2	1 3/8	1 3/8	1 5/8
20	(4) 5-DR	52'-11"	32500	1/2	1/2	1/2	1 3/8	1 3/8	1 5/8
21	(4) 4-DR & (1) 5-DR	55'-6 1/2"	34125	1/2	1/2	5/8	1 3/8	1 5/8	1 5/8
22	(3) 4-DR & (2) 5-DR	58'-2"	35750	1/2	1/2	5/8	1 3/8	1 5/8	1 5/8
23	(2) 4-DR & (3) 5-DR	60'-9 1/2"	37375	1/2	1/2	5/8	1 3/8	1 5/8	1 5/8
24	(1) 4-DR & (4) 5-DR	63'-5"	39000	1/2	5/8	5/8	1 3/8	1 5/8	1 5/8
25	(5) 5-DR	66'-1/2"	40625	1/2	5/8	5/8	1 3/8	1 5/8	1 5/8
26	(4) 4-DR & (2) 5-DR	68'-8"	42250	1/2	5/8	5/8	1 3/8	1 5/8	1 5/8
27	(3) 4-DR & (3) 5-DR	71'-3 1/2"	43875	1/2	5/8	5/8	1 3/8	1 5/8	2 1/8
28	(2) 4-DR & (4) 5-DR	73'-11"	45500	1/2	5/8	5/8	1 3/8	1 5/8	2 1/8
29	(1) 4-DR & (5) 5-DR	76'-6 1/2"	47125	1/2	5/8	5/8	1 3/8	1 5/8	2 1/8
30	(6) 5-DR	79'-2"	48750	1/2	5/8	5/8	1 3/8	1 5/8	2 1/8

BTU/HR RATING BASED ON 1500 mA T-10 LIGHTING. CASE DESIGNED TO OPERATE IN AN AMBIENT OF 75 °F OR LOWER AND RELATIVE HUMIDITY OF 55% OR LOWER

Table 5

ZERO ZONE

REMOTE REACH-IN FREEZER W/ 24" X 63" DOORS
MODEL RI-DFR-63
REFRIGERANT R-502, R-404a, R-507 @ -14 °F
EVAPORATOR FOR FROZEN FOOD

NO. OF DOORS	FREEZER COMBINATIONS	TOTAL LENGTH W/ENDS	BTU/HR	RECOMMENDED LIQUID LINE SIZES EQUIVALENT LENGTH, FEET			RECOMMENDED SUCTION LINE SIZES EQUIVALENT LENGTH, FEET		
				50	100	150	50	100	150
2	(1) 2-DR	4'-8 7/8"	3375	3/8	3/8	3/8	5/8	5/8	7/8
3	(1) 3-DR	6'-8 5/8"	4455	3/8	3/8	3/8	5/8	7/8	7/8
4	(1) 4-DR	8'-8 3/8"	5530	3/8	3/8	3/8	7/8	7/8	7/8
5	(1) 5-DR	10'-8 1/8"	6625	3/8	3/8	3/8	7/8	7/8	7/8
6	(2) 3-DR	13'-1 1/4"	7950	3/8	3/8	3/8	7/8	7/8	7/8
7	(1) 3-DR & (1) 4-DR	15'-0"	9275	3/8	3/8	3/8	7/8	7/8	1 1/8
8	(2) 4-DR	16'-11 3/4"	10600	3/8	1/2	1/2	7/8	1 1/8	1 1/8
9	(1) 4-DR & (1) 5-DR	18'-11 1/2"	11925	3/8	1/2	1/2	7/8	1 1/8	1 1/8
10	(2) 5-DR	20'-11 1/4"	13250	3/8	1/2	1/2	7/8	1 1/8	1 1/8
11	(1) 3-DR & (2) 4-DR	22'-10 3/8"	14575	3/8	1/2	1/2	7/8	1 1/8	1 1/8
12	(3) 4-DR	25'-3 1/4"	15900	3/8	1/2	1/2	1 1/8	1 1/8	1 1/8
13	(2) 4-DR & (1) 5-DR	27'-2 7/8"	17225	1/2	1/2	1/2	1 1/8	1 1/8	1 3/8
14	(1) 4-DR & (2) 5-DR	29'-2 5/8"	18550	1/2	1/2	1/2	1 1/8	1 1/8	1 3/8
15	(3) 5-DR	31'-2 3/8"	19875	1/2	1/2	1/2	1 1/8	1 1/8	1 3/8
16	(4) 4-DR	33'-6 1/2"	21200	1/2	1/2	1/2	1 1/8	1 3/8	1 3/8
17	(3) 4-DR & (1) 5-DR	35'-6 1/4"	22525	1/2	1/2	1/2	1 1/8	1 3/8	1 3/8
18	(2) 4-DR & (2) 5-DR	37'-6"	23850	1/2	1/2	5/8	1 1/8	1 3/8	1 3/8
19	(1) 4-DR & (3) 5-DR	39'-5 3/4"	25175	1/2	1/2	5/8	1 1/8	1 3/8	1 3/8
20	(4) 5-DR	41'-1 1/2"	26500	1/2	1/2	5/8	1 1/8	1 3/8	1 3/8
21	(4) 4-DR & (1) 5-DR	43'-9 5/8"	27825	1/2	1/2	5/8	1 1/8	1 3/8	1 3/8
22	(3) 4-DR & (2) 5-DR	45'-9 3/8"	29150	1/2	5/8	5/8	1 3/8	1 3/8	1 5/8
23	(2) 4-DR & (3) 5-DR	47'-9 1/8"	30475	1/2	5/8	5/8	1 3/8	1 3/8	1 5/8
24	(1) 4-DR & (4) 5-DR	49'-8 7/8"	31800	1/2	5/8	5/8	1 3/8	1 3/8	1 5/8
25	(5) 5-DR	51'-8 5/8"	33125	1/2	5/8	5/8	1 3/8	1 3/8	1 5/8
26	(4) 4-DR & (2) 5-DR	54'-3 1/4"	34450	1/2	5/8	5/8	1 3/8	1 3/8	1 5/8
27	(3) 4-DR & (3) 5-DR	56'-1 1/2"	35775	1/2	5/8	5/8	1 3/8	1 5/8	1 5/8
28	(2) 4-DR & (4) 5-DR	58'-1 1/4"	37100	1/2	5/8	5/8	1 3/8	1 5/8	1 5/8
29	(1) 4-DR & (5) 5-DR	60'-0"	38425	1/2	5/8	5/8	1 3/8	1 5/8	1 5/8
30	(6) 5-DR	61'-11 3/4"	39750	1/2	5/8	5/8	1 3/8	1 5/8	1 5/8

BTU/HR RATING BASED ON 1500 mA T-10 LIGHTING. CASE DESIGNED TO OPERATE IN AN AMBIENT OF 75 °F OR LOWER AND RELATIVE HUMIDITY OF 55% OR LOWER

REMOTE REACH-IN FREEZER W/ 24" X 63" DOORS
MODEL RI-DFR-63
REFRIGERANT R-502, R-404a, R-507 @ -20 °F
EVAPORATOR FOR ICE CREAM

NO. OF DOORS	FREEZER COMBINATIONS	TOTAL LENGTH W/ENDS	BTU/HR	RECOMMENDED LIQUID LINE SIZES EQUIVALENT LENGTH, FEET			RECOMMENDED SUCTION LINE SIZES EQUIVALENT LENGTH, FEET		
				50	100	150	50	100	150
2	(1) 2-DR	4'-8 7/8"	3620	3/8	3/8	3/8	5/8	7/8	7/8
3	(1) 3-DR	6'-8 5/8"	4775	3/8	3/8	3/8	7/8	7/8	7/8
4	(1) 4-DR	8'-8 3/8"	5930	3/8	3/8	3/8	7/8	7/8	7/8
5	(1) 5-DR	10'-8 1/8"	7100	3/8	3/8	3/8	7/8	7/8	1 1/8
6	(2) 3-DR	13'-1/4"	8520	3/8	3/8	3/8	7/8	1 1/8	1 1/8
7	(1) 3-DR & (1) 4-DR	15'-0"	9940	3/8	1/2	1/2	7/8	1 1/8	1 1/8
8	(2) 4-DR	16'-11 3/4"	11360	3/8	1/2	1/2	7/8	1 1/8	1 1/8
9	(1) 4-DR & (1) 5-DR	18'-11 1/2"	12780	3/8	1/2	1/2	1 1/8	1 1/8	1 1/8
10	(2) 5-DR	20'-11 1/4"	14200	3/8	1/2	1/2	1 1/8	1 1/8	1 3/8
11	(1) 3-DR & (2) 4-DR	22'-10 3/8"	15620	3/8	1/2	1/2	1 1/8	1 1/8	1 3/8
12	(3) 4-DR	25'-3 1/4"	17040	1/2	1/2	1/2	1 1/8	1 3/8	1 3/8
13	(2) 4-DR & (1) 5-DR	27'-2 7/8"	18460	1/2	1/2	1/2	1 1/8	1 3/8	1 3/8
14	(1) 4-DR & (2) 5-DR	29'-2 5/8"	19880	1/2	1/2	1/2	1 1/8	1 3/8	1 3/8
15	(3) 5-DR	31'-2 3/8"	21300	1/2	1/2	1/2	1 1/8	1 3/8	1 3/8
16	(4) 4-DR	33'-6 1/2"	22720	1/2	1/2	5/8	1 1/8	1 3/8	1 3/8
17	(3) 4-DR & (1) 5-DR	35'-6 1/4"	24140	1/2	1/2	5/8	1 3/8	1 3/8	1 5/8
18	(2) 4-DR & (2) 5-DR	37'-6"	25560	1/2	1/2	5/8	1 3/8	1 3/8	1 5/8
19	(1) 4-DR & (3) 5-DR	39'-5 3/4"	26980	1/2	1/2	5/8	1 3/8	1 3/8	1 5/8
20	(4) 5-DR	41'-1/2"	28400	1/2	5/8	5/8	1 3/8	1 3/8	1 5/8
21	(4) 4-DR & (1) 5-DR	43'-9 5/8"	29820	1/2	5/8	5/8	1 3/8	1 5/8	1 5/8
22	(3) 4-DR & (2) 5-DR	45'-9 3/8"	31240	1/2	5/8	5/8	1 3/8	1 5/8	1 5/8
23	(2) 4-DR & (3) 5-DR	47'-9 1/8"	32660	1/2	5/8	5/8	1 3/8	1 5/8	1 5/8
24	(1) 4-DR & (4) 5-DR	49'-8 7/8"	34080	1/2	5/8	5/8	1 3/8	1 5/8	1 5/8
25	(5) 5-DR	51'-8 5/8"	35500	1/2	5/8	5/8	1 3/8	1 5/8	1 5/8
26	(4) 4-DR & (2) 5-DR	54'-3/4"	36920	1/2	5/8	5/8	1 3/8	1 5/8	1 5/8
27	(3) 4-DR & (3) 5-DR	56'-1/2"	38340	1/2	5/8	5/8	1 3/8	1 5/8	2 1/8
28	(2) 4-DR & (4) 5-DR	58'-1/4"	39760	1/2	5/8	5/8	1 3/8	1 5/8	2 1/8
29	(1) 4-DR & (5) 5-DR	60'-0"	41180	5/8	5/8	5/8	1 3/8	1 5/8	2 1/8
30	(6) 5-DR	61'-11 3/4"	42600	5/8	5/8	7/8	1 5/8	1 5/8	2 1/8

BTU/HR RATING BASED ON 1500 mA T-10 LIGHTING. CASE DESIGNED TO OPERATE IN AN AMBIENT OF 75 °F OR LOWER AND RELATIVE HUMIDITY OF 55% OR LOWER

REMOTE REACH-IN FREEZER W/ 24" X 63" DOORS
MODEL RI-DFR-63
REFRIGERANT R-22 @ -14 °F
EVAPORATOR FOR FROZEN FOOD

NO. OF DOORS	FREEZER COMBINATIONS	TOTAL LENGTH W/ENDS	BTU/HR	RECOMMENDED LIQUID LINE SIZES EQUIVALENT LENGTH, FEET			RECOMMENDED SUCTION LINE SIZES EQUIVALENT LENGTH, FEET		
				50	100	150	50	100	150
2	(1) 2-DR	4'-8 7/8"	3375	3/8	3/8	3/8	5/8	5/8	5/8
3	(1) 3-DR	6'-8 5/8"	4455	3/8	3/8	3/8	5/8	7/8	7/8
4	(1) 4-DR	8'-8 3/8"	5530	3/8	3/8	3/8	5/8	7/8	7/8
5	(1) 5-DR	10'-8 1/8"	6625	3/4	3/8	3/8	7/8	7/8	7/8
6	(2) 3-DR	13'-1/4"	7950	3/4	3/8	3/8	7/8	7/8	7/8
7	(1) 3-DR & (1) 4-DR	15'-0"	9275	3/4	3/8	3/8	7/8	7/8	7/8
8	(2) 4-DR	16'-11 3/4"	10600	3/4	3/8	3/8	7/8	7/8	1 1/8
9	(1) 4-DR & (1) 5-DR	18'-11 1/2"	11925	3/4	3/8	1/2	7/8	7/8	1 1/8
10	(2) 5-DR	20'-11 1/4"	13250	3/4	3/8	1/2	7/8	1 1/8	1 1/8
11	(1) 3-DR & (2) 4-DR	22'-10 3/8"	14575	3/4	1/2	1/2	7/8	1 1/8	1 1/8
12	(3) 4-DR	25'-3 1/4"	15900	3/4	1/2	1/2	1 1/8	1 1/8	1 1/8
13	(2) 4-DR & (1) 5-DR	27'-2 7/8"	17225	3/4	1/2	1/2	1 1/8	1 1/8	1 1/8
14	(1) 4-DR & (2) 5-DR	29'-2 5/8"	18550	3/4	1/2	1/2	1 1/8	1 1/8	1 1/8
15	(3) 5-DR	31'-2 3/8"	19875	1/2	1/2	1/2	1 1/8	1 1/8	1 3/8
16	(4) 4-DR	33'-6 1/2"	21200	1/2	1/2	1/2	1 1/8	1 1/8	1 3/8
17	(3) 4-DR & (1) 5-DR	35'-6 1/4"	22525	1/2	1/2	1/2	1 1/8	1 1/8	1 3/8
18	(2) 4-DR & (2) 5-DR	37'-6"	23850	1/2	1/2	1/2	1 1/8	1 1/8	1 3/8
19	(1) 4-DR & (3) 5-DR	39'-5 3/4"	25175	1/2	1/2	1/2	1 1/8	1 3/8	1 3/8
20	(4) 5-DR	41'-1/2"	26500	1/2	1/2	1/2	1 1/8	1 3/8	1 3/8
21	(4) 4-DR & (1) 5-DR	43'-9 5/8"	27825	1/2	1/2	1/2	1 1/8	1 3/8	1 3/8
22	(3) 4-DR & (2) 5-DR	45'-9 3/8"	29150	1/2	1/2	1/2	1 1/8	1 3/8	1 3/8
23	(2) 4-DR & (3) 5-DR	47'-9 1/8"	30475	1/2	1/2	1/2	1 3/8	1 3/8	1 3/8
24	(1) 4-DR & (4) 5-DR	49'-8 7/8"	31800	1/2	1/2	1/2	1 3/8	1 3/8	1 3/8
25	(5) 5-DR	51'-8 5/8"	33125	1/2	1/2	1/2	1 3/8	1 3/8	1 3/8
26	(4) 4-DR & (2) 5-DR	54'-3/4"	34450	1/2	1/2	1/2	1 3/8	1 3/8	1 3/8
27	(3) 4-DR & (3) 5-DR	56'-1/2"	35775	1/2	1/2	5/8	1 3/8	1 3/8	1 5/8
28	(2) 4-DR & (4) 5-DR	58'-1/4"	37100	1/2	1/2	5/8	1 3/8	1 3/8	1 5/8
29	(1) 4-DR & (5) 5-DR	60'-0"	38425	1/2	1/2	5/8	1 3/8	1 3/8	1 5/8
30	(6) 5-DR	61'-11 3/4"	39750	1/2	1/2	5/8	1 3/8	1 3/8	1 5/8

BTU/HR RATING BASED ON 1500 mA T-10 LIGHTING. CASE DESIGNED TO OPERATE IN AN AMBIENT OF 75 °F OR LOWER AND RELATIVE HUMIDITY OF 55% OR LOWER

REMOTE REACH-IN FREEZER W/ 24" X 63" DOORS
MODEL RI-DFR-63
REFRIGERANT R-22 @ -20 °F
EVAPORATOR FOR ICE CREAM

NO. OF DOORS	FREEZER COMBINATIONS	TOTAL LENGTH W/ENDS	BTU/HR	RECOMMENDED LIQUID LINE SIZES EQUIVALENT LENGTH, FEET			RECOMMENDED SUCTION LINE SIZES EQUIVALENT LENGTH, FEET		
				50	100	150	50	100	150
2	(1) 2-DR	4'-8 7/8"	3620	3/8	3/8	3/8	5/8	7/8	7/8
3	(1) 3-DR	6'-8 5/8"	4775	3/8	3/8	3/8	5/8	7/8	7/8
4	(1) 4-DR	8'-8 3/8"	5930	3/8	3/8	3/8	7/8	7/8	7/8
5	(1) 5-DR	10'-8 1/8"	7100	3/8	3/8	3/8	7/8	7/8	7/8
6	(2) 3-DR	13'-1/4"	8520	3/8	3/8	3/8	7/8	7/8	1 1/8
7	(1) 3-DR & (1) 4-DR	15'-0"	9940	3/8	3/8	1/2	7/8	1 1/8	1 1/8
8	(2) 4-DR	16'-11 3/4"	11360	3/8	3/8	1/2	7/8	1 1/8	1 1/8
9	(1) 4-DR & (1) 5-DR	18'-11 1/2"	12780	3/8	3/8	1/2	7/8	1 1/8	1 1/8
10	(2) 5-DR	20'-11 1/4"	14200	3/8	1/2	1/2	7/8	1 1/8	1 1/8
11	(1) 3-DR & (2) 4-DR	22'-10 3/8"	15620	3/8	1/2	1/2	1 1/8	1 1/8	1 1/8
12	(3) 4-DR	25'-3 1/4"	17040	3/8	1/2	1/2	1 1/8	1 1/8	1 3/8
13	(2) 4-DR & (1) 5-DR	27'-2 7/8"	18460	1/2	1/2	1/2	1 1/8	1 1/8	1 3/8
14	(1) 4-DR & (2) 5-DR	29'-2 5/8"	19880	1/2	1/2	1/2	1 1/8	1 3/8	1 3/8
15	(3) 5-DR	31'-2 3/8"	21300	1/2	1/2	1/2	1 1/8	1 3/8	1 3/8
16	(4) 4-DR	33'-6 1/2"	22720	1/2	1/2	1/2	1 1/8	1 3/8	1 3/8
17	(3) 4-DR & (1) 5-DR	35'-6 1/4"	24140	1/2	1/2	1/2	1 1/8	1 3/8	1 3/8
18	(2) 4-DR & (2) 5-DR	37'-6"	25560	1/2	1/2	1/2	1 1/8	1 3/8	1 3/8
19	(1) 4-DR & (3) 5-DR	39'-5 3/4"	26980	1/2	1/2	1/2	1 1/8	1 3/8	1 3/8
20	(4) 5-DR	41'-1/2"	28400	1/2	1/2	1/2	1 1/8	1 3/8	1 3/8
21	(4) 4-DR & (1) 5-DR	43'-9 5/8"	29820	1/2	1/2	1/2	1 3/8	1 3/8	1 5/8
22	(3) 4-DR & (2) 5-DR	45'-9 3/8"	31240	1/2	1/2	1/2	1 3/8	1 3/8	1 5/8
23	(2) 4-DR & (3) 5-DR	47'-9 1/8"	32660	1/2	1/2	1/2	1 3/8	1 3/8	1 5/8
24	(1) 4-DR & (4) 5-DR	49'-8 7/8"	34080	1/2	1/2	5/8	1 3/8	1 3/8	1 5/8
25	(5) 5-DR	51'-8 5/8"	35500	1/2	1/2	5/8	1 3/8	1 3/8	1 5/8
26	(4) 4-DR & (2) 5-DR	54'-3/4"	36920	1/2	1/2	5/8	1 3/8	1 5/8	1 5/8
27	(3) 4-DR & (3) 5-DR	56'-1/2"	38340	1/2	1/2	5/8	1 3/8	1 5/8	1 5/8
28	(2) 4-DR & (4) 5-DR	58'-1/4"	39760	1/2	1/2	5/8	1 3/8	1 5/8	1 5/8
29	(1) 4-DR & (5) 5-DR	60'-0"	41180	1/2	5/8	5/8	1 3/8	1 5/8	1 5/8
30	(6) 5-DR	61'-11 3/4"	42600	1/2	5/8	5/8	1 3/8	1 5/8	1 5/8

BTU/HR RATING BASED ON 1500 ma T-10 LIGHTING. CASE DESIGNED TO OPERATE IN AN AMBIENT OF 75 °F OR LOWER AND RELATIVE HUMIDITY OF 55% OR LOWER

KTB SPECIFICATION SHEET

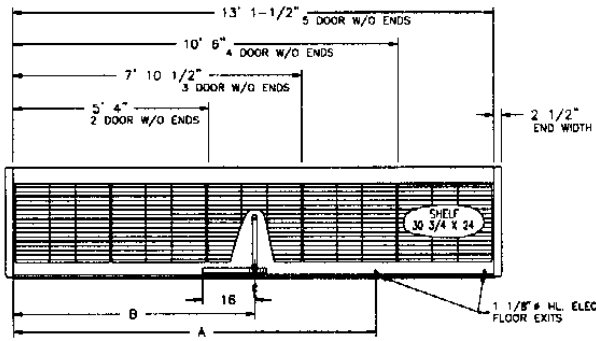

Section A-A

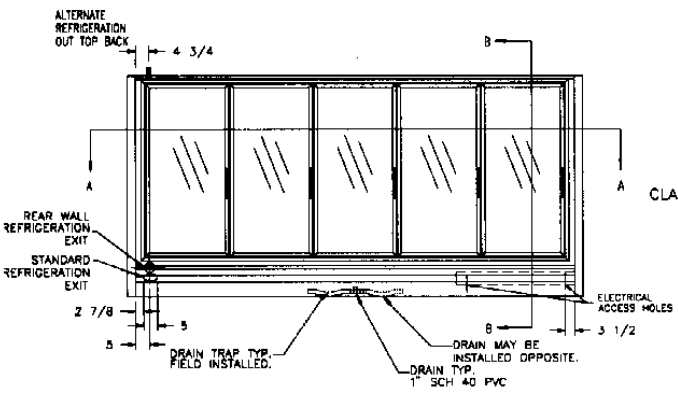

Front Elevation

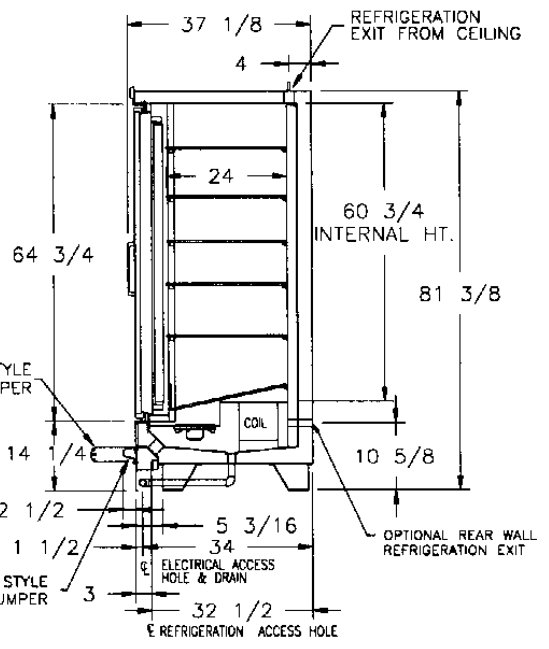

Section B-B

ELECTRICAL CONNECTION (A) & DRAIN(B) LOCATION SCHEDULE	CASE SHIPPING WEIGHT		
	A	B	POUNDS
2KTB	35 1/2	32	778
3KTB	58	47 1/4	1102
4KTB	89 1/2	63	1414
5KTB	121	78 3/4	1882

	REFRIGERATION CONNECTIONS FOR ELECTRIC DEFROST	
	SUCTION LINE O.D.	LIQUID LINE O.D.
2KTB	7/8	3/8
3KTB	7/8	1/2
4KTB	1 1/8	1/2
5KTB	1 1/8	1/2

	REFRIGERATION CONNECTIONS FOR HOT GAS DEFROST	
	SUCTION LINE O.D.	LIQUID LINE O.D.
2KTB	7/8	3/8
3KTB	7/8	3/8
4KTB	1 1/8	3/8
5KTB	1 1/8	3/8

Figure 5

SZ SPECIFICATION SHEET

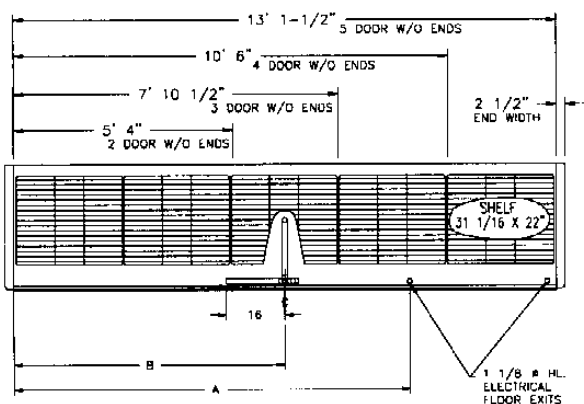

Section A-A

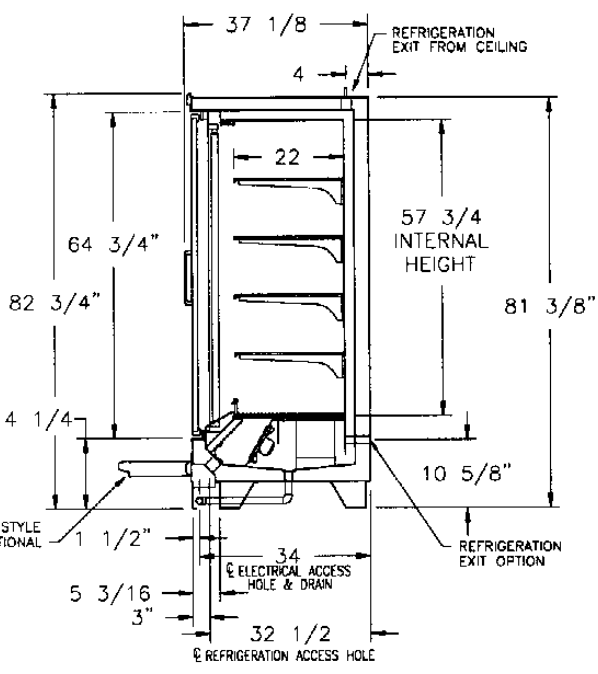

Section B-B

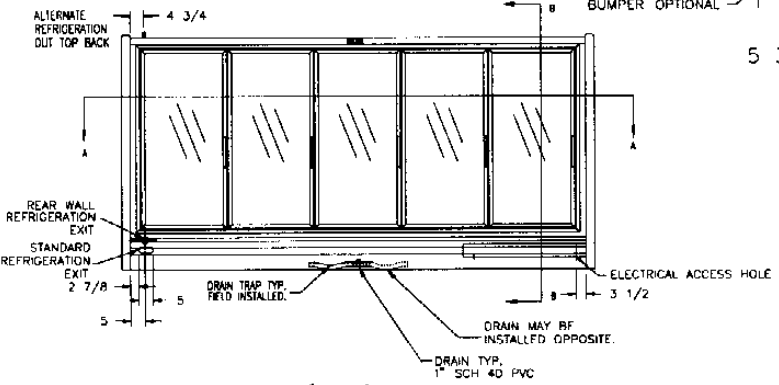

Front Elevation

	ELECTRICAL CONNECTION (A) & DRAIN(B) LOCATION SCHEDULE		CASE SHIPPING WEIGHT
	A	B	
2SZ	35 1/2	32	837
3SZ	58	47 1/4	1211
4SZ	89 1/2	63	1564
5SZ	121	78 3/4	1956

	REFRIGERANT CONNECTIONS SIZES FOR HOT GAS DEFROST	
	SUCTION LINE O.D.	LIQUID LINE O.D.
2SZ	7/8	3/8
3SZ	7/8	1/2
4SZ	1-1/8	1/2
5SZ	1-1/8	1/2

	REFRIGERANT CONNECTIONS SIZES FOR ELECTRIC DEFROST	
	SUCTION LINE O.D.	LIQUID LINE O.D.
2SZ	7/8	3/8
3SZ	7/8	3/8
4SZ	1-1/8	3/8
5SZ	1-1/8	3/8

Figure 6

DFR-63 SPECIFICATION SHEET

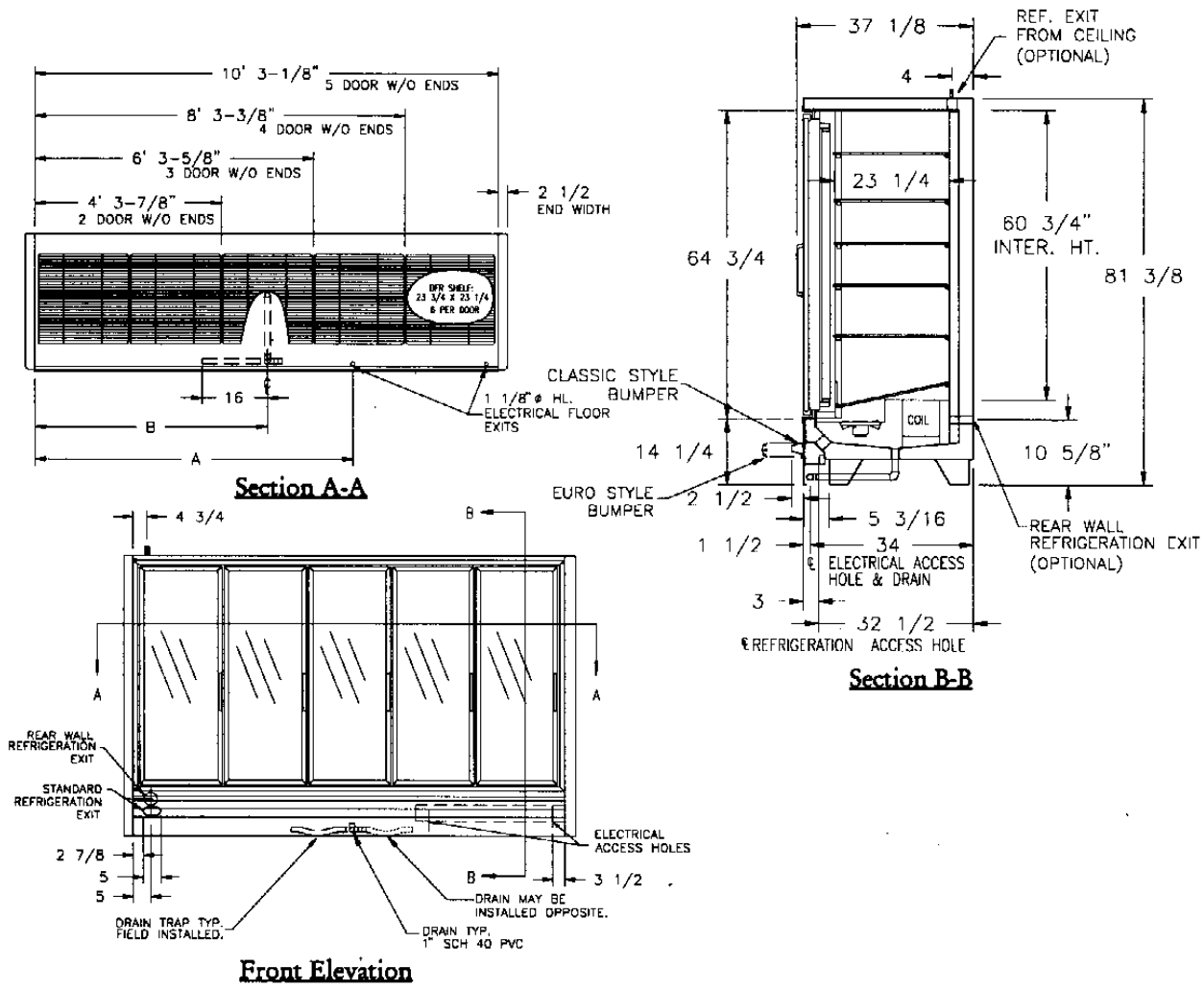

	ELECTRICAL CONNECTION (A) & DRAIN(B) LOCATION SCHEDULE		CASE SHIPPING WEIGHT POUNDS
	A	B	
2 DFR-63	23 3/8	25 15/16	608
3 DFR-63	39 1/8	37 4/5	880
4 DFR-63	62 7/8	49 11/16	1151
5 DFR-63	86 5/8	61 4/7	1431

	REFRIGERANT CONNECTIONS		
	ELECTRIC DEFROST		
	TOP SUCTION LINE O.D.	STANDARD BOTTOM SUCTION LINE O.D.	BOTTOM & TOP LIQUID LINE O.D.
2 DFR-63	5/8	7/8	3/8
3 DFR-63	7/8	7/8	3/8
4 DFR-63	7/8	7/8	3/8
5 DFR-63 R-22	7/8	1 1/8	3/8
5 DFR-63 R-502	1 1/8	1 1/8	3/8

	REFRIGERANT CONNECTIONS		
	HOT GAS DEFROST		
	TOP SUCTION LINE O.D.	STANDARD BOTTOM SUCTION LINE O.D.	BOTTOM & TOP LIQUID LINE O.D.
2 DFR-63	5/8	7/8	1/2
3 DFR-63	7/8	7/8	1/2
4 DFR-63	7/8	7/8	1/2
5 DFR-63 R-22	7/8	1 1/8	1/2
5 DFR-63 R-502	1 1/8	1 1/8	1/2

Figure 7

DOOR FRAME WIRE COLOR CODE
LIGHTS: BLK-RED/WHITE OR BLK/BRN
FRAMES: PURPLE-WHITE
MULLION: RED-WHITE
DOOR: ORANGE-WHITE
FANS: BLACK-WHITE

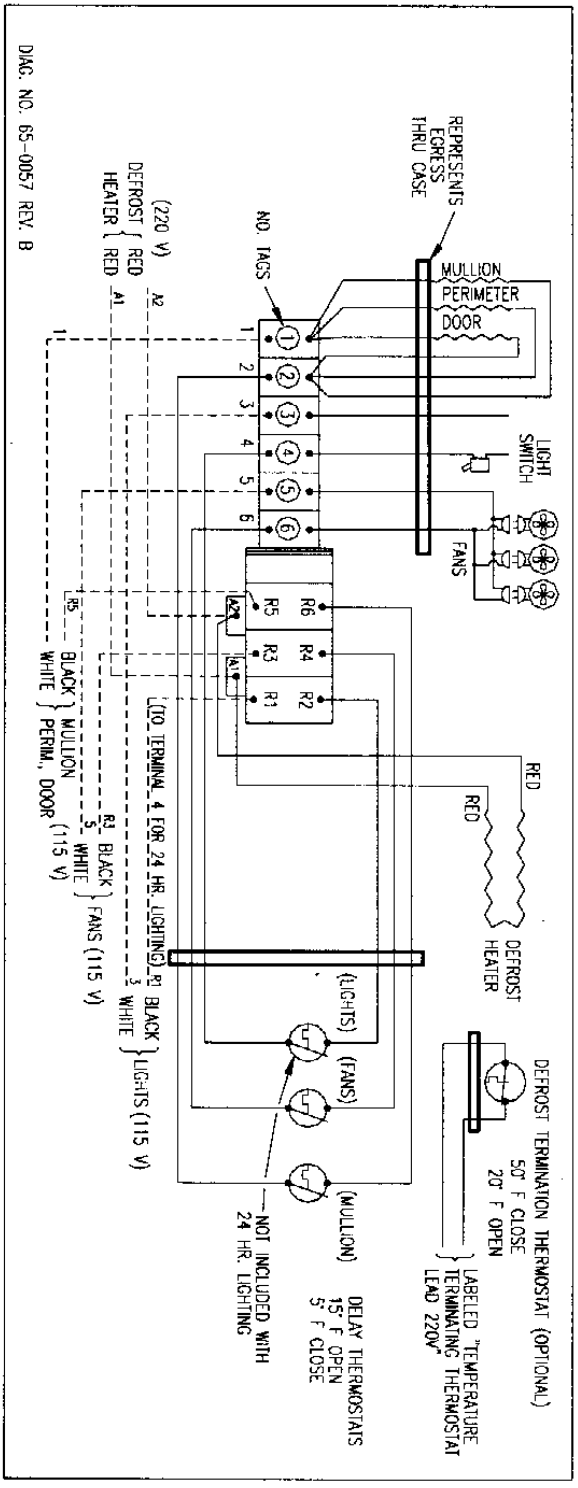

NOTES:
 DELAY THERMOSTATS (KILXON) LOCATED ON RIGHT SIDE OF CONT.
 BALLASTS LOCATED BEHIND KICKPLATE OR DOOR MULLION.

DMG. NO. 65-0057 REV. B

SZ/KTB/DFR-63 ELECTRIC DEFROST WIRING DIAGRAM

Figure 10

SZ/KTB/DFR-63 HOT GAS DEFROST WIRING DIAGRAM

Figure 11

DOOR FRAME WIRE COLOR CODE
 LIGHTS: BLK-RED/WHITE OR BLK/BRN
 FRAMES: PURPLE-WHITE
 MULLION: RED-WHITE
 DOOR: ORANGE-WHITE
 FANS: BLACK-WHITE

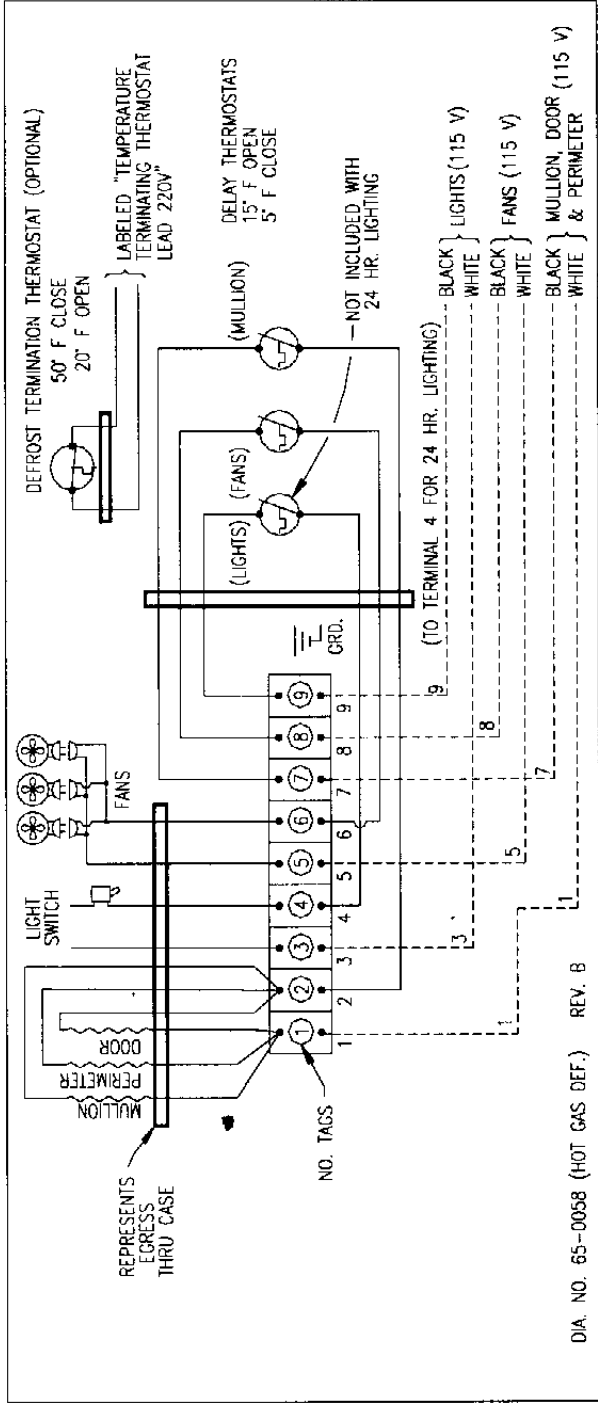

NOTES:
 DELAY THERMOSTATS (KLIXONS) LOCATED ON RIGHT SIDE OF COIL.
 BALLASTS LOCATED BEHIND KICKPLATE OR DOOR MULLION.

SZ/KTB/DFR-63 WIRING DIAGRAM FOR TIME/TEMPERATURE DEFROST

Figure 12

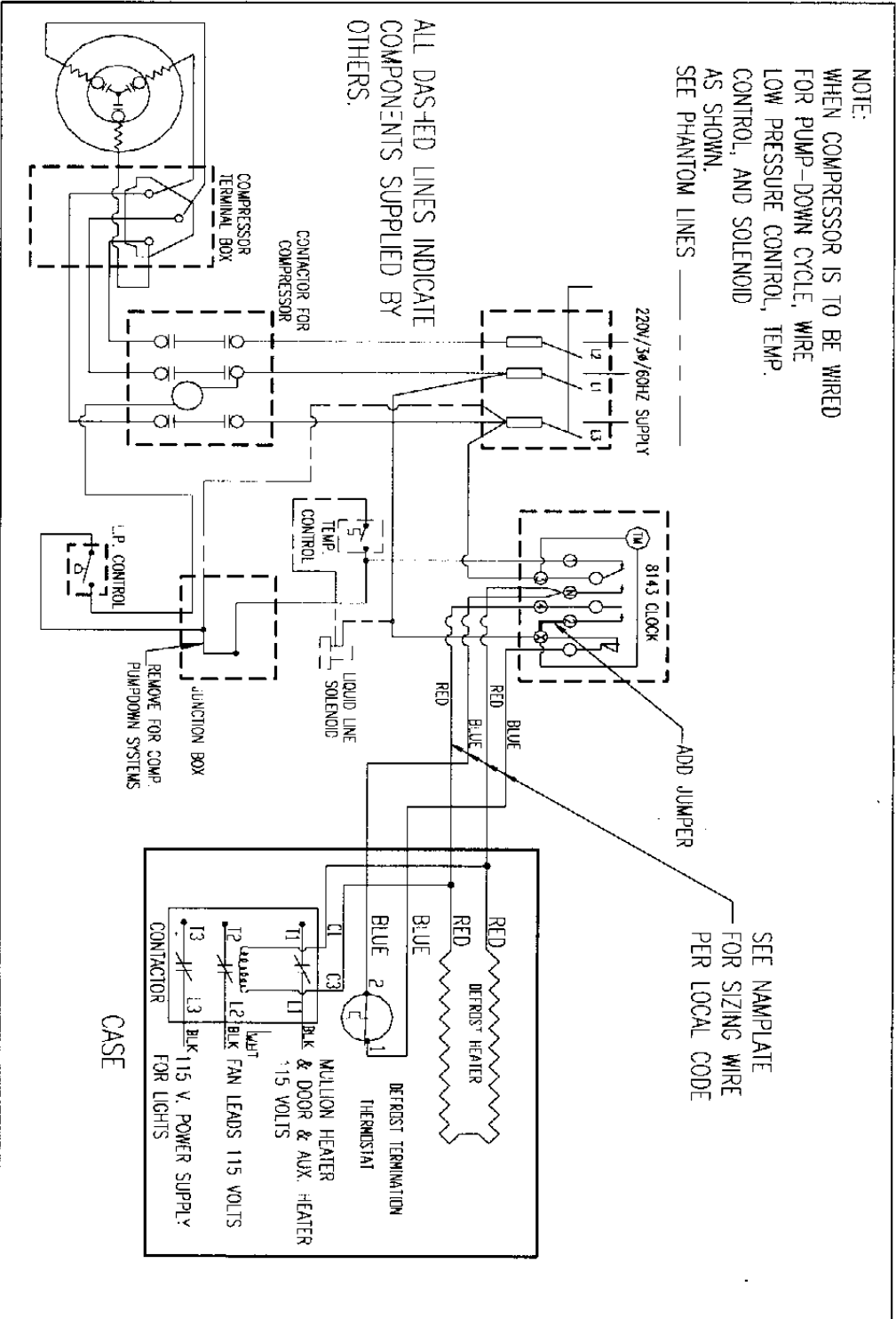

ELECTRICAL SPECIFICATIONS FOR SZ/KTB BY DOOR MANUFACTURER										
	FANS AMPS	LIGHT AMPS ONE END*	LIGHT AMPS BOTH ENDS	(T-8) LIGHTS AMPS	STD. DOOR	MULLION	FRAME	FRAMELESS DOOR	TOTAL FRAME MULLION STD. DOOR	DEFROST HEATER AMPS 220V/1/60Hz.
ANTHONY DOORS										
2-DFR-SZ/KTB	1.02	1.5	2.25	1.45	1.78	0.63	2.01	1.82	4.42	6.3
3-DFR-SZ/KTB	1.36	2.25	3	1.94	2.67	1.26	2.51	2.73	6.44	10
4-DFR-SZ/KTB	1.7	3	3.75	2.42	3.56	1.89	2.87	3.64	8.32	12.5
5-DFR-SZ/KTB	2.04	3.75	4.5	2.91	4.45	2.52	3.5	4.55	10.47	15.9
ARDCO DOORS										
2-DFR-SZ/KTB	1.02	1.5	2.25	1.89	2.2	1.22	2.1	2.2	5.52	6.3
3-DFR-SZ/KTB	1.36	2.25	3	2.34	3.3	1.83	2.7	3.3	7.83	10
4-DFR-SZ/KTB	1.7	3	3.75	3.06	4.4	2.44	3	4.4	9.84	12.5
5-DFR-SZ/KTB	2.04	3.75	4.5	3.51	5.5	3.05	3.5	5.5	12.05	15.9
COMMERCIAL DOORS										
2-DFR-SZ/KTB	1.02	1.5	2.25	N/A	2.47	0.9	1.56	N/A	4.93	6.3
3-DFR-SZ/KTB	1.36	2.25	3	N/A	3.71	1.8	1.76	N/A	7.27	10
4-DFR-SZ/KTB	1.7	3	3.75	N/A	4.95	2.7	1.84	N/A	9.49	12.5
5-DFR-SZ/KTB	2.04	3.75	4.5	N/A	6.18	3.6	2.12	N/A	11.9	15.9
* STANDARD FOR CASE IN A LINE-UP VOLTAGE: 115 Volts 1 Phase 60 Hz.										

ELECTRICAL SPECIFICATIONS FOR DFR-63 BY DOOR MANUFACTURER										
	FANS AMPS	LIGHT AMPS ONE END*	LIGHT AMPS BOTH ENDS	(T-8) LIGHT AMPS	STD. DOOR	MULLION	FRAME	FRAMELESS DOOR	TOTAL FRAME MULLION STD. DOOR	DEFROST HEATER AMPS 220V/1/60Hz.
ANTHONY DOORS										
2-DFR-63	0.68	1.5	2.25	1.45	1.48	0.62	1.89	1.56	3.99	5.5
3-DFR-63	1.02	2.25	3	1.94	2.22	1.24	2.25	2.34	5.71	8
4-DFR-63	1.36	3	3.75	2.42	2.96	1.86	2.65	3.12	7.47	10
5-DFR-63	1.7	3.75	4.5	2.91	3.7	2.48	3.1	3.9	9.28	12.5
ARDCO DOORS										
2-DFR-63	0.68	1.65	2.4	1.89	1.7	1.12	1.9	1.7	4.72	5.5
3-DFR-63	1.02	2.4	3.3	2.34	2.55	1.68	2.4	2.55	6.63	8
4-DFR-63	1.36	3.3	4.05	3.06	3.4	2.24	2.7	3.4	8.34	10
5-DFR-63	1.7	4.05	4.8	3.51	4.25	2.8	3.1	4.25	10.15	12.5
COMMERCIAL DOORS										
2-DFR-63	0.68	1.5	2.25	N/A	1.7	0.9	1.36	N/A	3.96	5.5
3-DFR-63	1.02	2.25	3	N/A	2.56	1.8	1.44	N/A	5.8	8
4-DFR-63	1.36	3	3.75	N/A	3.41	2.7	1.72	N/A	7.83	10
5-DFR-63	1.7	3.75	4.5	N/A	4.26	3.6	1.88	N/A	9.74	12.5
* STANDARD FOR CASE IN A LINE-UP VOLTAGE: 115 Volts 1 Phase 60 Hz.										

Electrical Values

Figure 13

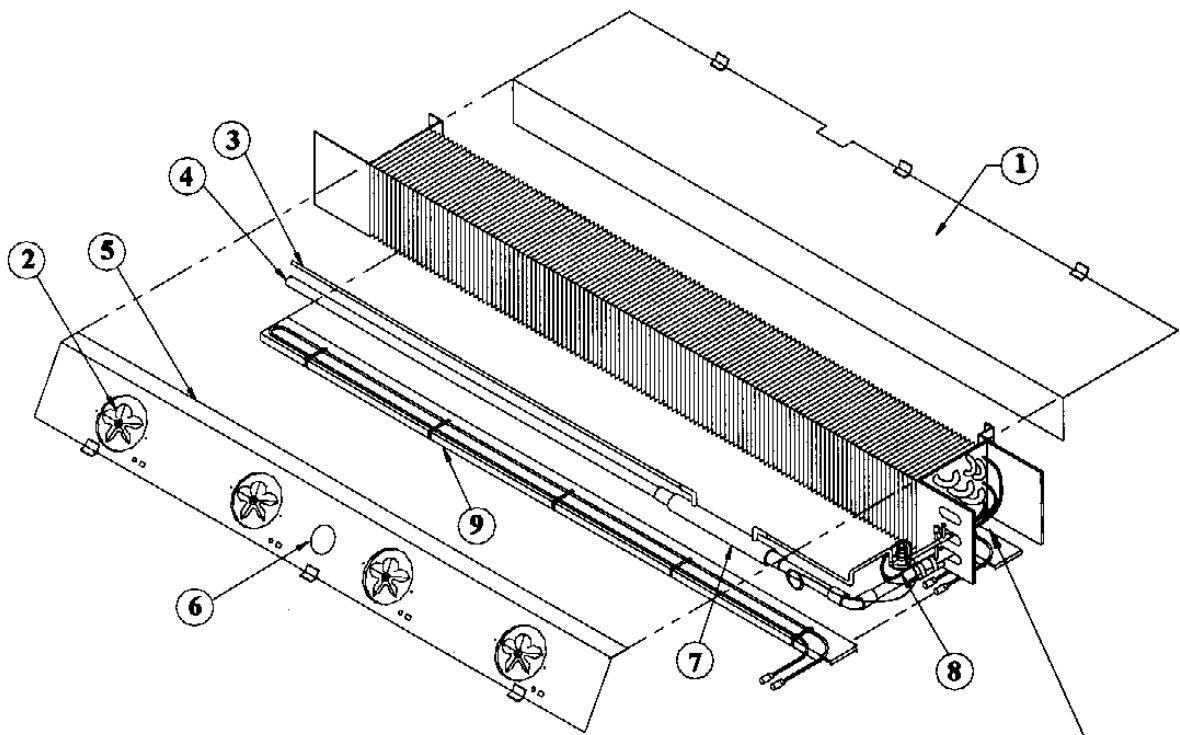

Fan, Lights, and Door
Heater Limit Thermostat
attached to return bends

1. Coil Cover
2. Fan
3. Liquid Line
4. Suction Line
5. Fan Housing
6. Drain Access Cover
7. Heat Exchanger
8. Expansion Valve
9. Heating Element

SZ Electric Defrost

Figure 16

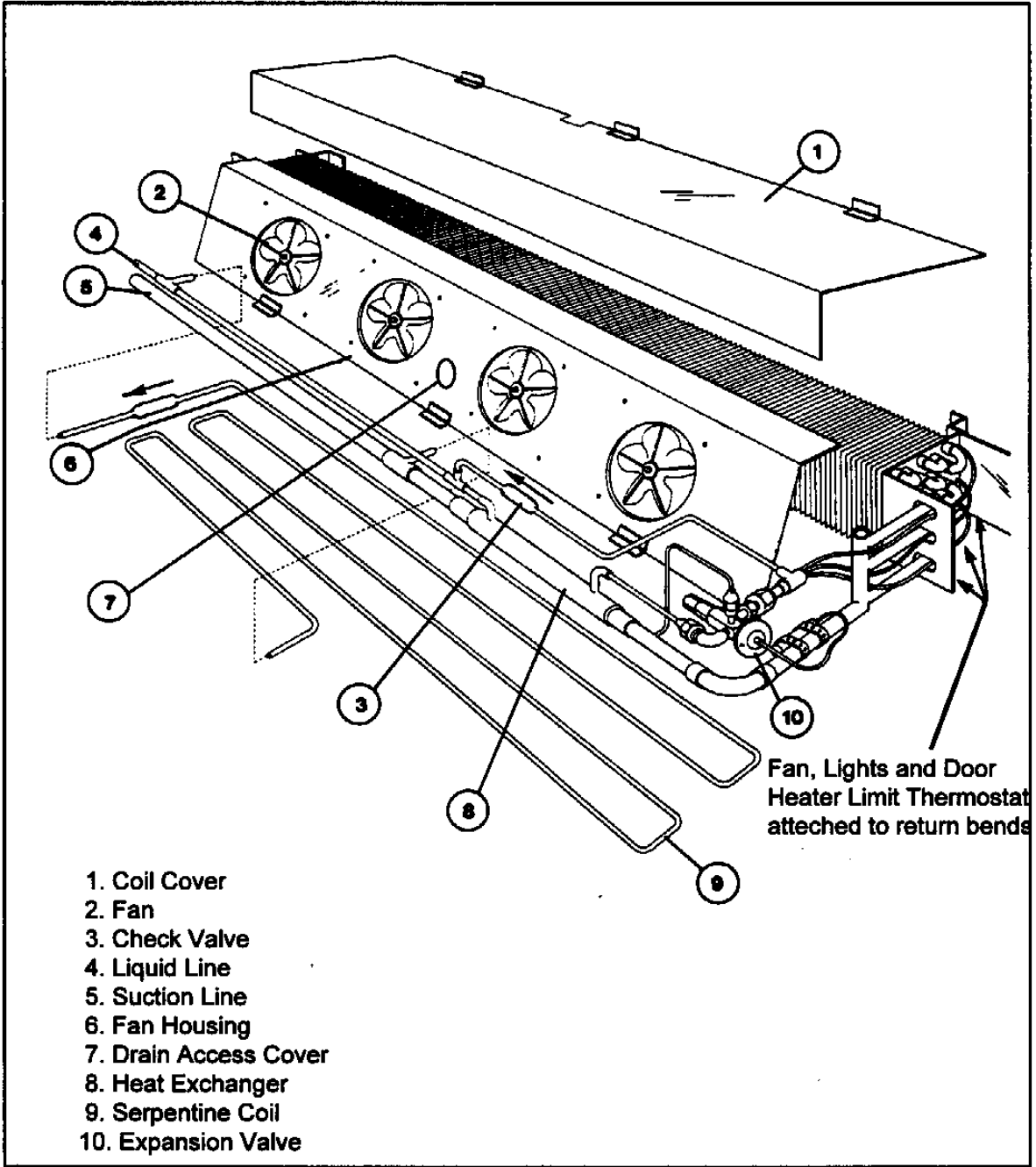

SZ Hot Gas Defrost

Figure 17

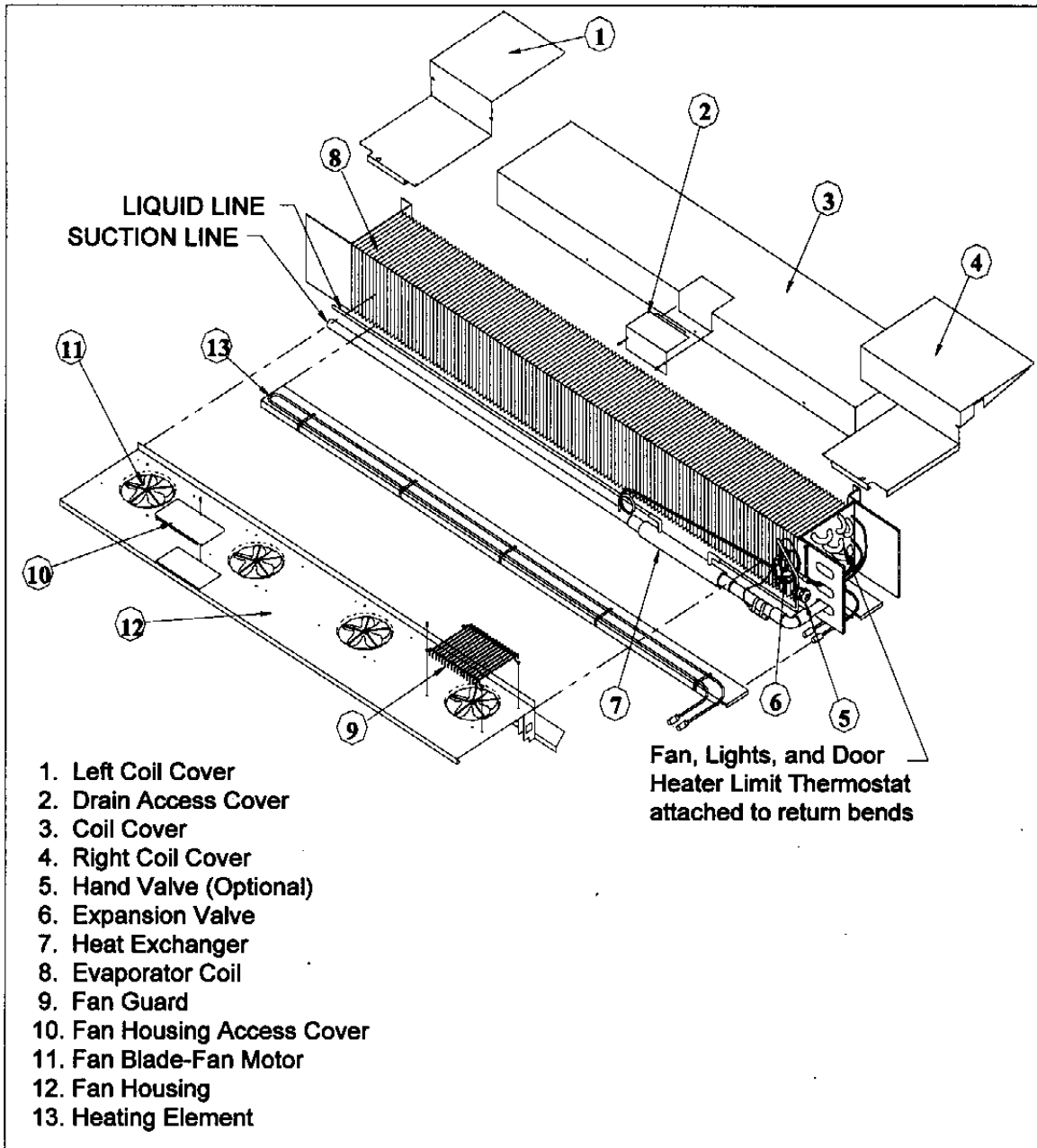

KTB/DFR-63 Electric Defrost

Figure 18

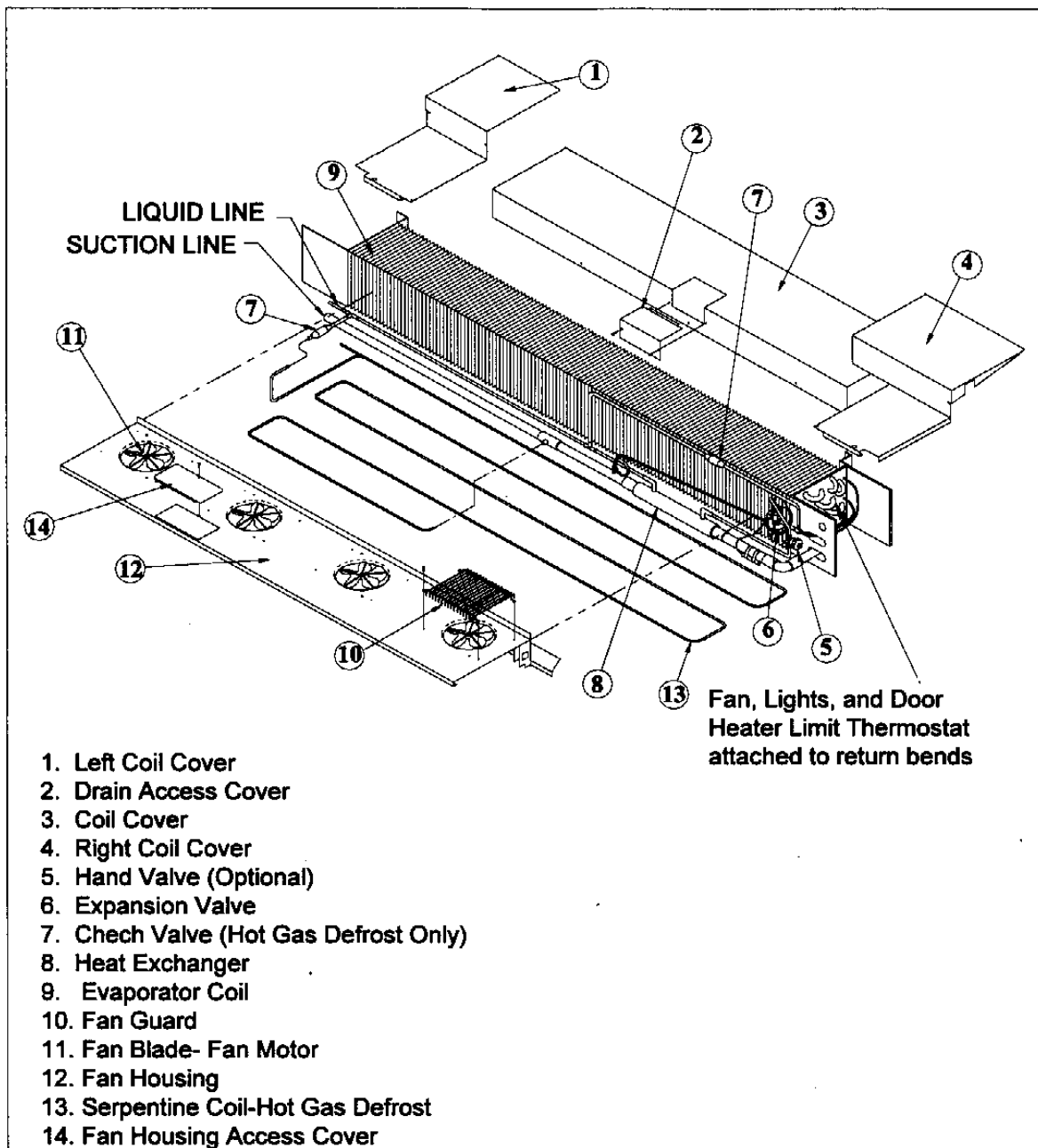

KTB/DFR-63 Hot Gas Defrost

Figure 19

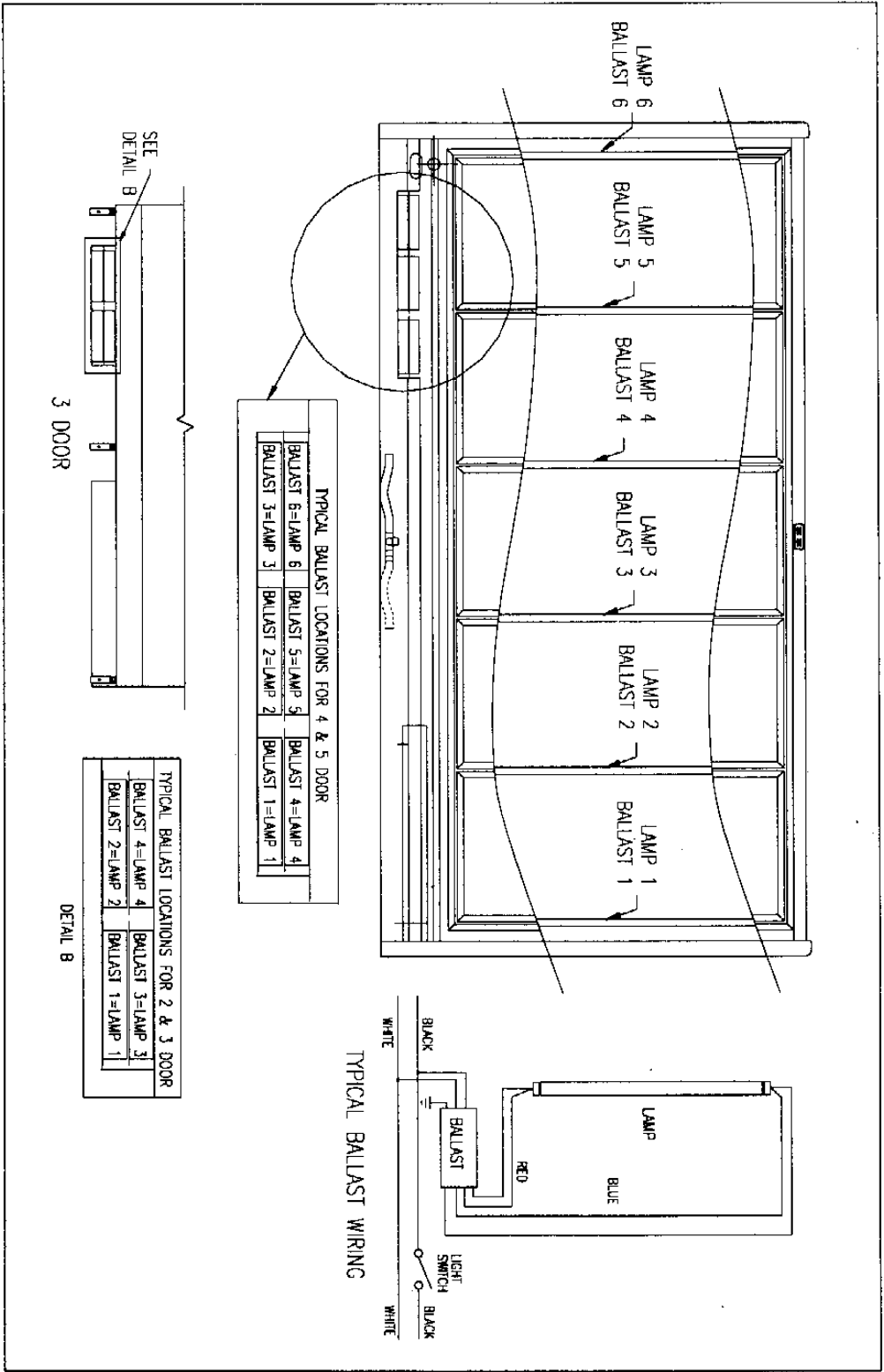

TYPICAL BALLAST LOCATIONS FOR 4 & 5 DOOR

BALLAST 6=LAMP 6	BALLAST 5=LAMP 5	BALLAST 4=LAMP 4
BALLAST 3=LAMP 3	BALLAST 2=LAMP 2	BALLAST 1=LAMP 1

TYPICAL BALLAST LOCATIONS FOR 2 & 3 DOOR

BALLAST 4=LAMP 4	BALLAST 3=LAMP 3
BALLAST 2=LAMP 2	BALLAST 1=LAMP 1

SZ/KTB/DFR-63 LIGHT/BALLAST WIRING DIAGRAM

Figure 21