

CASE CAULKING INSTRUCTIONS RHLC/RHMC

Before joining the cases, remove all packaging material on the display case, including any spacer blocks inside the bases. Repeat caulking between each case in the lineup.

CASE JOINT CAULKING (BUTYL*)

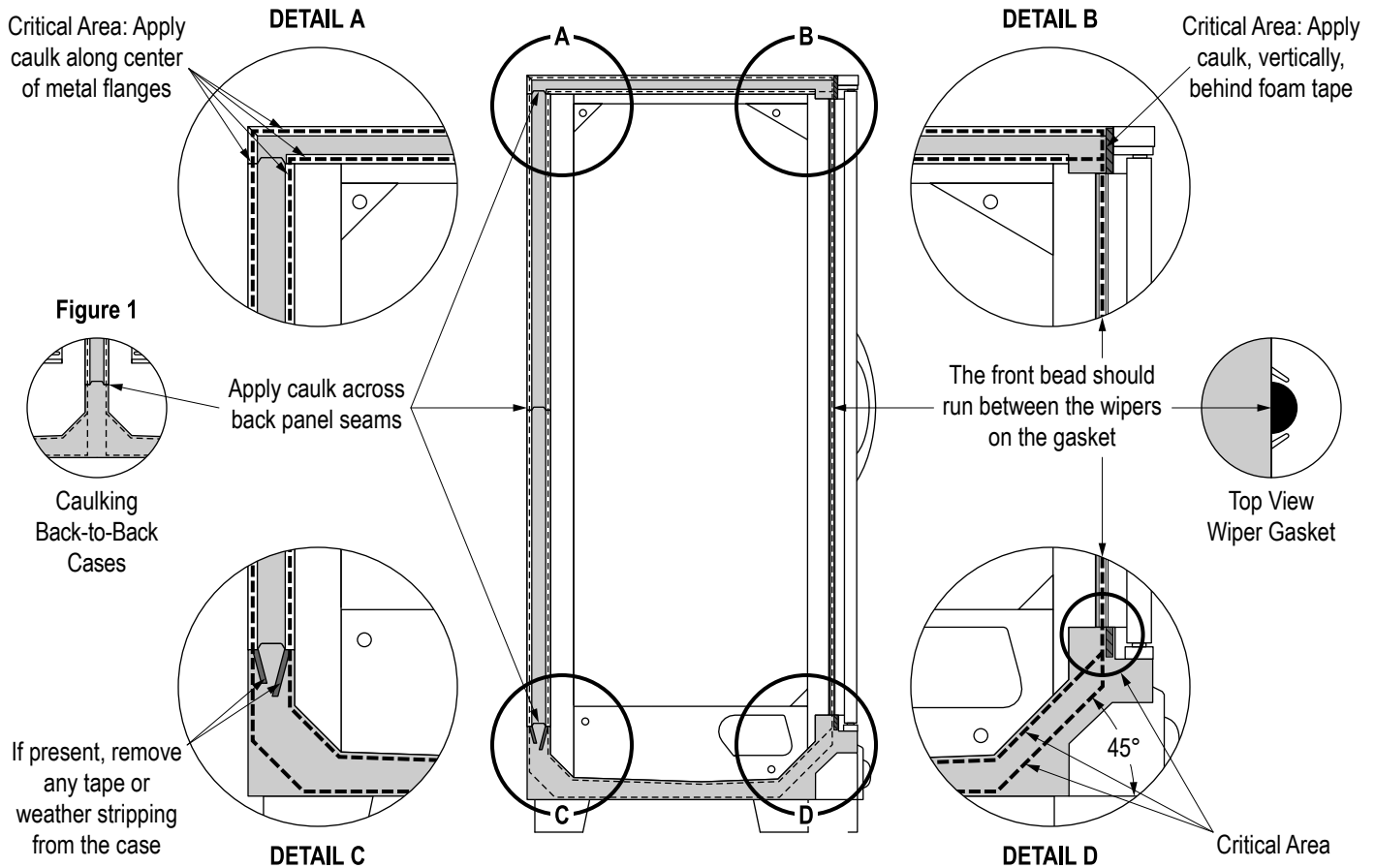

IT IS CRITICAL TO FOLLOW THIS PROCEDURE TO ENSURE CASES ARE PROPERLY SEALED.

SURFACES TO BE CAULKED MUST BE CLEAN, DRY, FREE OF TAPE/ADHESIVE, AND FREE OF FROST (ABOVE 40°F).

Note: Apply Butyl caulk to only one case—not both cases. The caulk will spread out when the cases are pushed together, and excessive caulk may squeeze out of the joint. Wipe away any caulk that squeezes out. Butyl caulk will not mix with silicone sealant (used for NSF sealing), which will affect adhesion of both.

1. Apply 3/8" thick beads of Butyl caulk* along the ceiling, rear wall, bottom of the case, and the mullion where indicated by the dashed lines in the drawing. Caulk must be continuous with no gaps. Always apply 2 beads where specified. Caulk must be applied around a plexiglass divider and not onto the divider itself, if applicable.
2. After cases are joined and tightened, caulk the top and back exterior seams, if accessible, to ensure a tight seal.
3. Back-to-Back (BB models) share the rear wall. Apply 2 beads of caulk along the shared rear wall as shown in **Figure 1**.
4. Refer to the Installation & Operation Manual for information about NSF compliance sealing with silicone sealant.

*DO NOT APPLY BUTYL CAULK ON SEAFOOD OR BAKERY CASES. Butyl caulk never cures and emits vapors that affect seafood and bakery products. Recommended alternative caulk: Polyurethane-based (full curing, durable, moisture-activated) or silicone-based (full curing).

