



# Display Freezers

**INSTALLATION  
and OPERATING INSTRUCTIONS for**



## RMZC30 Series



## RMZP30 Series



## RMZP24 Series



Zero Zone, Inc. • 110 N. Oakridge Dr. • North Prairie, WI 53153-9792  
1-800-247-4496 • FAX: 1-414-392-6450 • [www.zero-zone.com](http://www.zero-zone.com)

CRMA  
Certified



06995M21000129



## TABLE OF CONTENTS

SUBJECT	
<b>GENERAL INFORMATION</b> .....	<b>1</b>
INTRODUCTION .....	1
INSPECTION .....	1
LOCATION .....	1
<b>INSTALLATION</b> .....	<b>1</b>
LEVELING .....	1
JOINING FREEZERS .....	3
DRAIN LINE .....	3
CART BUMPER .....	3
<b>REFRIGERATION</b> .....	<b>3</b>
GENERAL .....	3
REFRIGERANT PIPING .....	5
TEMPERATURE CONTROL .....	5
TEMPERATURE CONTROL ADJUSTMENT .....	5
LEAK CHECK-EVACUATION-CHARGING .....	5
<b>ELECTRICAL</b> .....	<b>6</b>
<b>DEFROSTING</b> .....	<b>6</b>
GENERAL .....	6
ELECTRIC DEFROST .....	7
GAS DEFROST .....	7
LIMIT THERMOSTAT .....	7
<b>USER INFORMATION</b> .....	<b>8</b>
CLEANING .....	8
SHELF LOCATION .....	8
LOADING THE FREEZER .....	8
LIGHT SWITCH .....	8
<b>SERVICE</b> .....	<b>8</b>
CART BUMPER .....	8
EVAPORATOR .....	8
EXPANSION VALVE .....	8-9
DEFROST HEATER ELEMENT .....	9
RMZC/P30 HEATER ELEMENT REMOVAL .....	9
RMZP24 HEATER ELEMENT REMOVAL .....	9
EVAPORATOR FANS .....	9
RMZC/P30 FAN REMOVAL .....	9
RMZP24 FAN REMOVAL .....	9
LIGHTS .....	9-10



BALLASTS .....	10
ALTERNATE LIGHTING - T8 .....	10
<b>TABLES</b>	
TABLE 1 RMZC/P30 LINE SIZE -14 F R502, R404a, R507 .....	11
TABLE 2 RMZC/P30 LINE SIZE -20 F R502, R404a, R507 .....	12
TABLE 3 RMZC/P30 LINE SIZE -14 F R22 .....	13
TABLE 4 RMZC/P30 LINE SIZE -20 F R22 .....	14
TABLE 5 RMZP24 LINE SIZE -14 F R502, R404a, R507 .....	15
TABLE 6 RMZP24 LINE SIZE -20 F R502, R404a, R507 .....	16
TABLE 7 RMZP24 LINE SIZE -14 F R22 .....	17
TABLE 8 RMZP24 LINE SIZE -20 F R22 .....	18
<b>FIGURES</b>	
FIGURE 1 LEVELING CASES PRIOR TO JOINING .....	2
FIGURE 2 CAULKING CASES TO BE JOINED .....	2
FIGURE 3 JOINING 24" DOOR REACH-IN FREEZERS .....	2
FIGURE 4 JOINING 30" DOOR REACH-IN FREEZERS .....	4
FIGURE 5 INSTALLING TEE STRIPS .....	4
FIGURE 6 INSTALLING THE CART BUMPER .....	4
FIGURE 7 TEMPERATURE CONTROL SETTINGS .....	5
FIGURE 8 TYPICAL TEMPERATURE CONTROLS .....	6
FIGURE 9 DEFROST FREQUENCY AND TERMINATION .....	7
FIGURE 10 RMZC30 SPECIFICATION SHEET .....	19-20
FIGURE 11 RMZP30 SPECIFICATION SHEET .....	21-22
FIGURE 12 RMZP24 SPECIFICATION SHEET .....	23-24
FIGURE 13 RMZC/P30/24 ELECTRIC DEFROST WIRING DIAGRAM .....	25
FIGURE 14 RMZC/P30/24 HOT GAS DEFROST WIRING DIAGRAM .....	26
FIGURE 15 RMZC/P30/24 WIRING DIAGRAM FOR TIME/TEMPERATURE DEFROST .....	27
FIGURE 16 RMZC/P30 ELECTRIC DEFROST ASSEMBLY .....	28
FIGURE 17 RMZC/P30 HOT GAS DEFROST ASSEMBLY .....	29
FIGURE 18 RMZP24 ELECTRIC DEFROST ASSEMBLY .....	30
FIGURE 19 RMZP24 HOT GAS DEFROST .....	31
<b>WARRANTY</b> .....	32



## GENERAL INFORMATION

### Introduction

The information contained in this manual pertains to the following Maximizer display freezers: RMZC30, RMZP30 and RMZP24. These cases are used for merchandising frozen food or ice cream. The RMZC30 and RMZP30 cases have 30-inch wide doors and utilize the revolutionary new S-coil. The RMZP24 has 24" wide doors and utilizes our traditional oversized coil. Zero Zone has made every effort to produce refrigeration equipment of the highest quality using state-of-the-art components.

These display freezers were designed to operate in an air-conditioned store where the temperature is maintained at 75°F or lower and the relative humidity is 55% or lower.

### Inspection

These display freezers were carefully factory-tested, inspected and properly packed to ensure delivery in the best possible condition. The equipment should be uncrated and checked for damage immediately upon delivery. **ALL CLAIMS FOR DAMAGES MUST BE FILED WITH THE TRANSPORTATION COMPANY - NOT WITH ZERO ZONE.** The carrier will supply necessary report and claim forms.

### Location

These freezers must not be installed in the direct rays of the sun or near a source of radiant heat.

Be certain that the floor under the installation is of sufficient strength to prevent sagging. Out of level conditions will result in reduced performance.

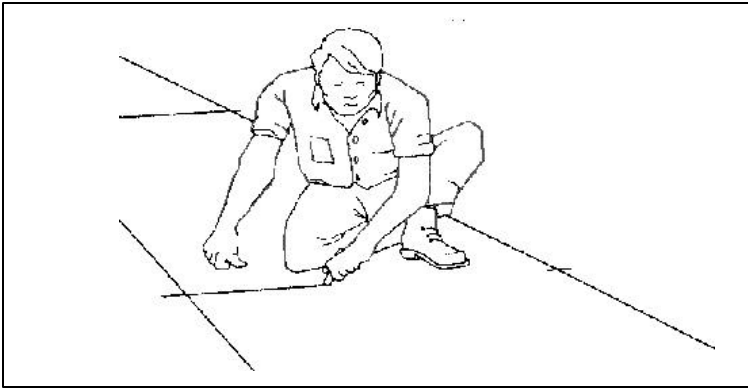
Wall cases, and back to back cases, should be positioned to allow a minimum 2 - 4 inch space behind the back of a unit. This will allow necessary air to circulate behind the unit.

## INSTALLATION

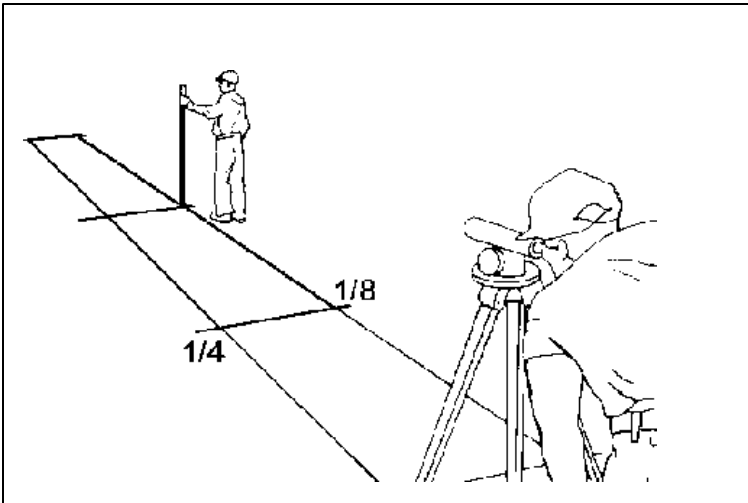
### Leveling (See Figure 1)

Refrigeration equipment must be installed perfectly level to allow efficient operation of the refrigeration coils and complete drainage of defrost water. Since a level area is seldom available, the following steps are recommended to insure a level installation.

1. Measure off and mark on floor the exact dimensions of the case line-up. (Check blueprints).
2. Snap a chalk line at the locations for the front and back positions of the base rails.
3. Mark locations of all joints (front and back).
4. Using a transit, find the highest point along both base rail position lines. Using the high point as a reference, mark the difference directly on the floor to each joint (front and back).
5. If a transit is not available, a water level can be used to mark reference elevation points. Water levels can be purchased from a contractor supply house for a minimal cost.
6. A string level can also be used to mark elevation points. The string level should only be used on short line-ups to avoid string sag.
7. Place the required number of shims (supplied) at each joint (front and back) to equal the highest point. Tape all shims in place.
8. Place additional support shims at the center of four and five door cases base rails (front and back).
9. Use a carpenter's level to check installation as you go. The case should be level from front to back and side to side. Install the case at the highest point first, if part of a line-up.



Measure and mark exact case outline



Mark floor level differences

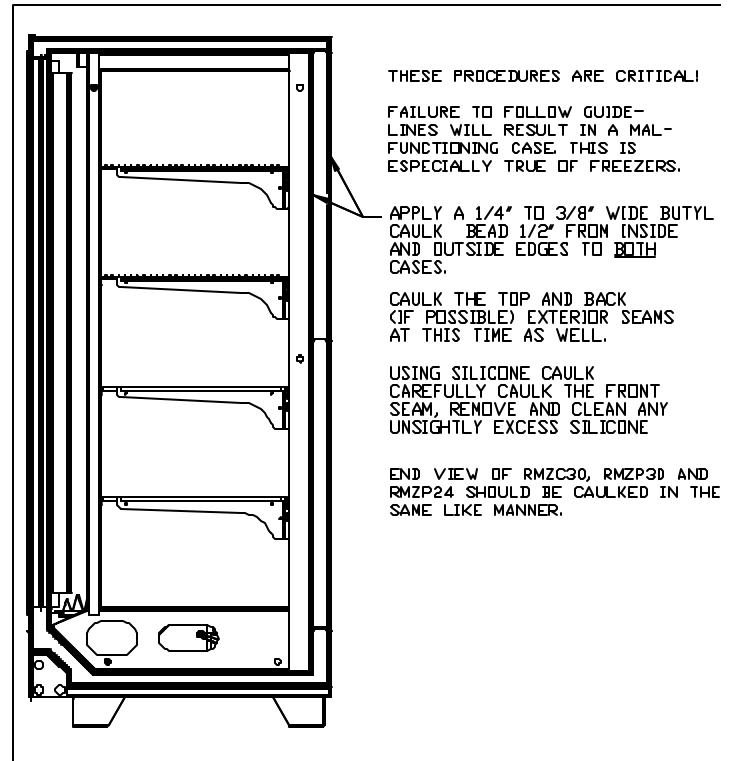
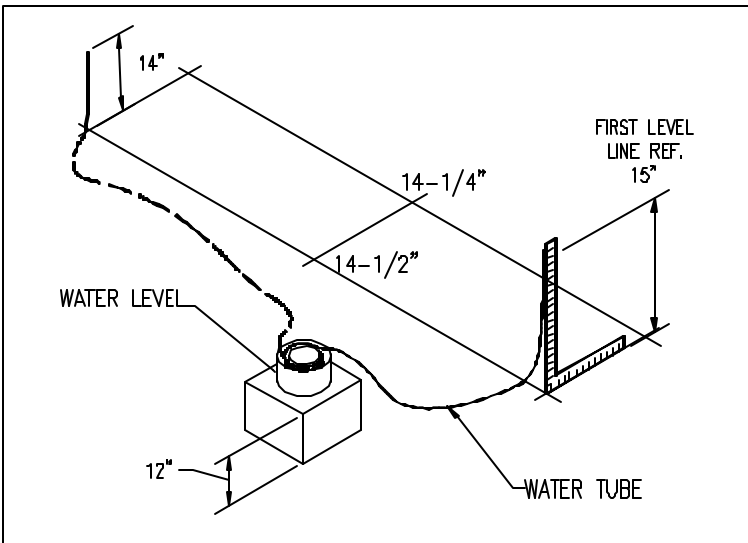
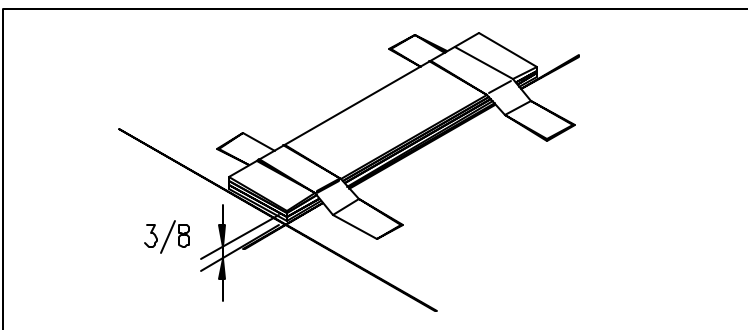


Figure 2: Caulking cases to be joined



Water level elevation points



Shim joints to equal highest points

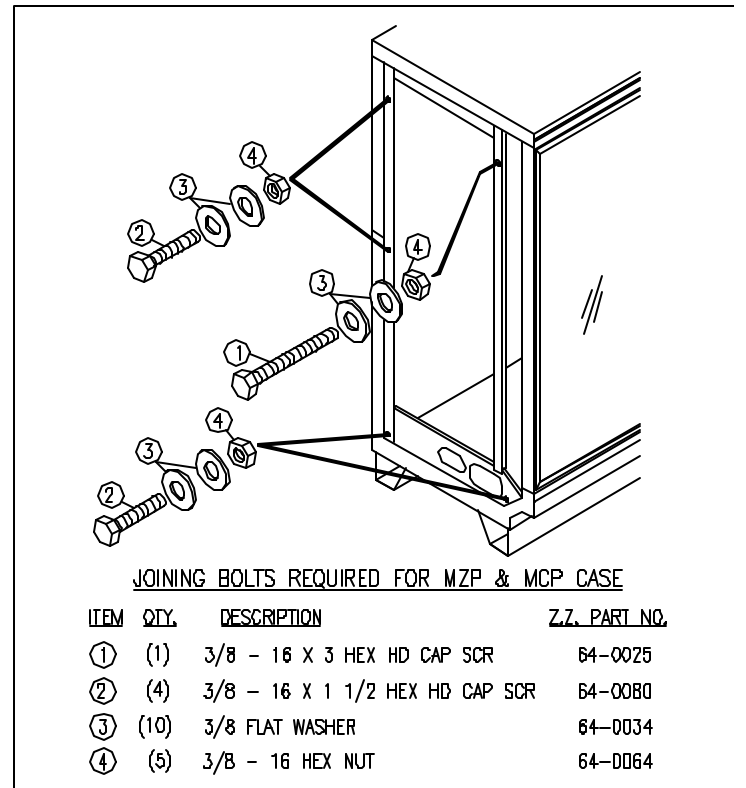


Figure 3: Joining 24" Door Reach-In Freezers



## Joining Freezers

These reach-in freezers have been engineered for continuous display. This means that any number of cases can be joined together to create a display of any desired length. Reach-In freezers are built on permanent steel skids to promote easy installation. The cases can be moved on pipe rollers or with a Johnson Bar. The ends of the case are protected with a removable steel plate.

To install Reach-Ins, perform the following steps:

1. Set the first Reach-In into the desired position and level it. Run a 3/8-inch diameter bead of Butyl caulk 1/2 inch in from both the inner and outer surfaces of the case end. (See Figure 2)
2. Push the second Reach-In against the end of the first. Level the second Reach-In. Remove the left and right end coil covers and the rectangular pocket hole covers, accessing the holes in the end panels of each freezer as shown. (See Figure 3 for 24" door cases and Figure 4 for 30" door cases). Install tee strips between the doorframes at case joints on 30" door cases. (See Figure 5) Use the special screws and nuts provided.
3. Start the joining bolts, but do not tighten them. Begin tightening the bolts at the top rear, working down the back of the case and up the front making sure that the front seams are flush.

## Drain Line

The drain is located at the center of the freezer in the floor pan. On all 30" door cases, the drain can be reached by removing the center coil covers. A plastic access cover can then be removed from the fan housing. On all 24" door cases, a small center cover can be removed to access the drain. The 1-inch PVC drain outlet is located at the center front of the freezer behind the kick plate.

Install a tee to the outlet pipe and a PVC drain trap to the tee. Plug the open end of the tee using the clean-out plug supplied with the drain trap kit. The drain line must be pitched away from the case a minimum of 1/4 inch per foot. The tee, drain trap, and plug are supplied standard with the case.

## Cart Bumper

The cart bumper should be installed at the bottom front of the case. (See Figure 6) The assembly is adjustable to compensate for uneven floors.

Center and hook the bumper assembly on the hangers provided.

In continuous line-ups, place a kick plate joint strip at each joint. On case ends, lineup an end kick plate with the front mounting holes. Fasten the rear of the end kick plate to the case using TECH screws.

Slide the front kick plate behind the bumper assembly and in front of the end kick plate or kick plate joint strip. Install three screws (two screws on 2-door only) to hold the kick plate and bumper in place. The screws attach the kickplate to a bracket with a timmerman.

A bumper joint strip can be installed over the bumper at the joints. This is standard on Euro Style Trim and optional on Classic Style Trim.

## **REFRIGERATION**

### General

Unless otherwise specified, the liquid and suction connections are made inside the case under the evaporator fan/coil cover. Refrigerant piping may enter the case through the front left bottom. (See Figure 10, 11, and 12) Alternate locations are out the left rear bottom of case or left rear top of case. After connections have been made, the refrigeration access hole in the freezer must be sealed completely with aerosol-dispensed Urethane insulation or equivalent (ie: great stuff).

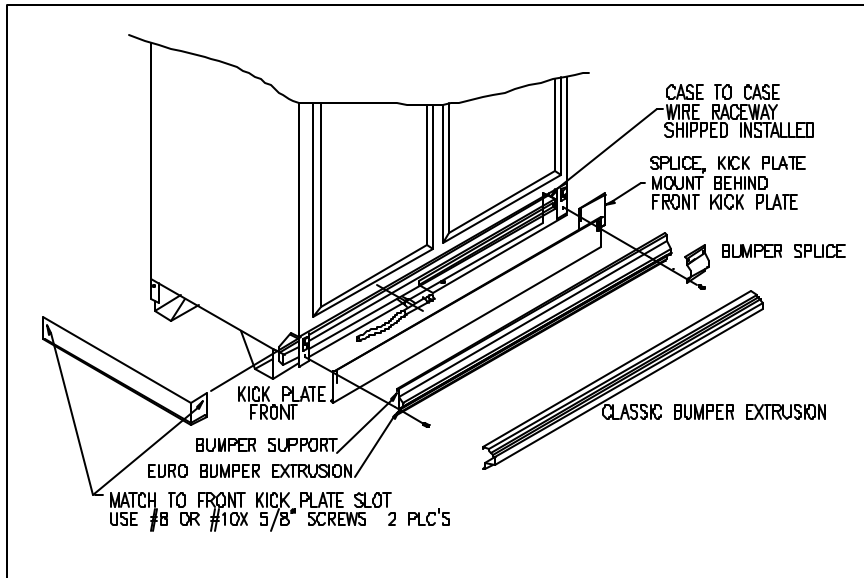


Figure 6: Installing The Cart Bumper

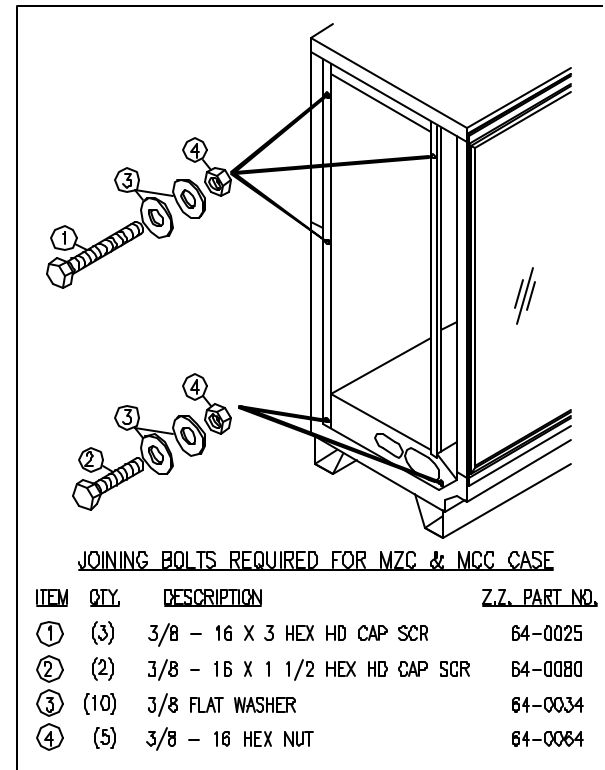


Figure 4: Joining 30" Door Reach-In Freezers

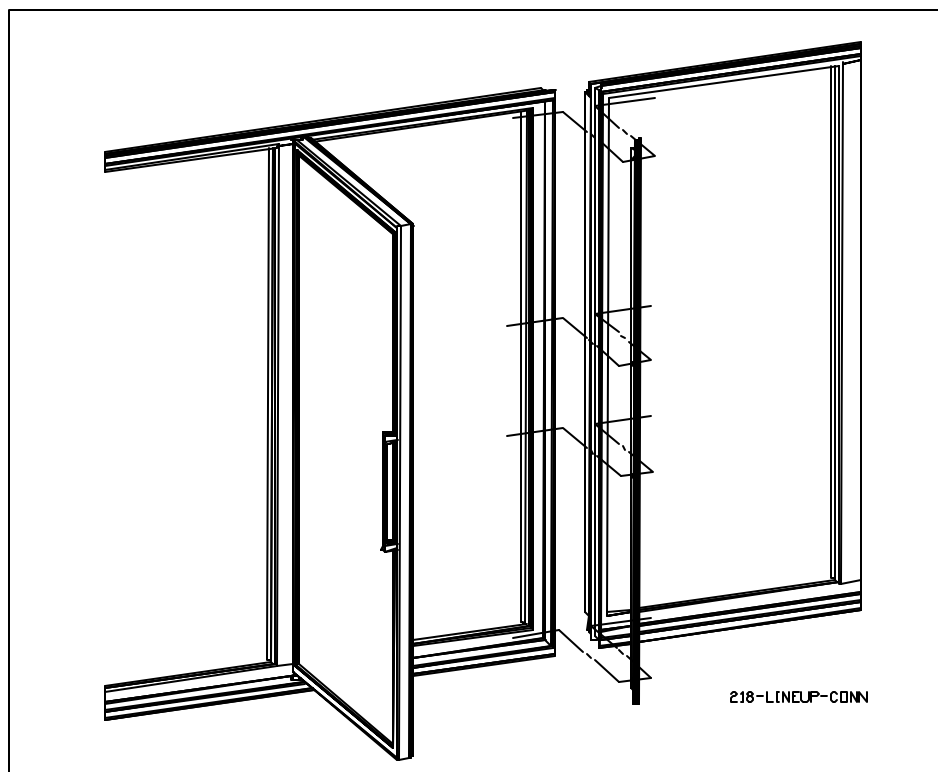


Figure 5: Installing Tee Strips



## Refrigerant Piping

Correct refrigeration line sizing and installation is essential for proper system operation. The following tables (Tables 1 through 8) list R502, R404A, R507, and R-22 line sizes for different combinations of frozen food and ice cream freezers. A P-trap must be installed at the bottom of all vertical suction risers.

When two or more freezer sections are connected to one compressor, the main liquid and suction line for the group should be run through the freezers and brought out through the refrigeration outlet of one freezer only. A piping chase allows the refrigerant lines to be run out of the right or left end frame.

The compressor should be installed as close as possible to the freezers to reduce pressure drop. If the compressor is located above the freezer, check the refrigerant line size tables (Tables 1 through 8) in the back of this manual to determine the riser line size. Install a shallow trap at the bottom of the riser. Use a flexible connection (vibration eliminator) between the suction line and compressor.

The suction and liquid lines may be taped together to form an external heat exchanger. Insulate the tubing for at least 20 feet from the freezer outlet.

The best location for the liquid line drier is inside the freezing compartment. However, it may be installed near the compressor for easy maintenance. Install moisture indicating sight glass at the outlet end of the drier.

## Temperature Control

A low pressure or temperature control can be used to control freezer temperature. The control should be selected with adequate contact capacity for the switching load. In rack systems, an evaporator pressure-regulating valve may be used to control the evaporating temperature.

The settings (See Figure 7) are approximate due to variations in gauge accuracy, differences in compressor efficiency, line pressure drop and super

	Frozen Food				
	Pressure (psig)				RETURN AIR TEMP.
	R-22	R502	R404A	R507	
Cut In	24	31	33	35	+2°F
Cut Out	14	19	21	22	-4°F
	Ice Cream				
	Pressure (psig)				RETURN AIR TEMP.
	R-22	R-502	R404A	R507	
Cut In	19	25	26	28	-5°F
Cut Out	9	14	15	17	-11°F

Figure 7: Temperature Control Settings

heat settings. Before making adjustments for store or stocking conditions, make sure the super heat is set between 6°F and 10°F.

## Temperature Control Adjustment

When factory installed, the temperature control is located toward the right end of the freezer behind the black kick plate. The sensing bulb is located under the coil cover inside the cabinet. It should be wired in series with the low-pressure (L.P.) control. The wiring diagram (Figure 16) shows use of the thermostat in a pump down system. (Figure 8) shows two types of temperature controls.

## Leak Check-Evacuation-Charging

After all of the refrigeration piping and system components have been assembled, the entire system must be pressurized and checked for leaks. Use nitrogen and refrigerant vapor to check for leaks. A Halide leak detector or an electronic leak detector is recommended.

If the system is sealed, evacuate with a deep vacuum pump. Triple evacuation to a minimum of 500 microns and nitrogen sweep is recommended. After the system has been thoroughly evacuated of all moisture and non-condensable gas, charge the system with the proper refrigerant, using "hi-side/low-side" charging techniques.



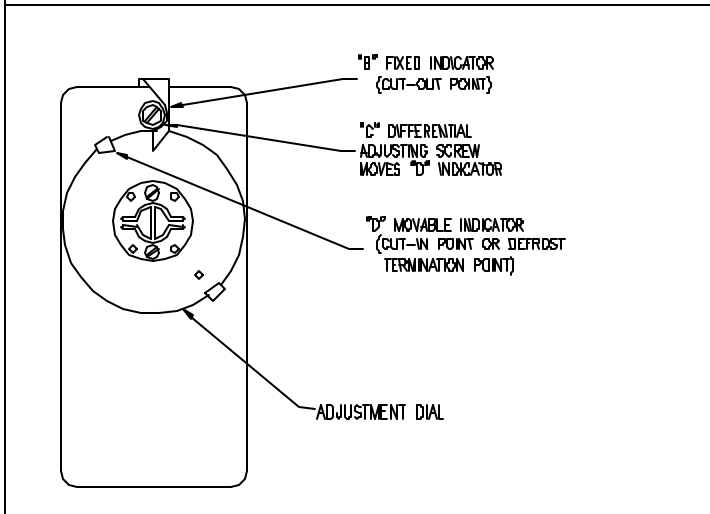
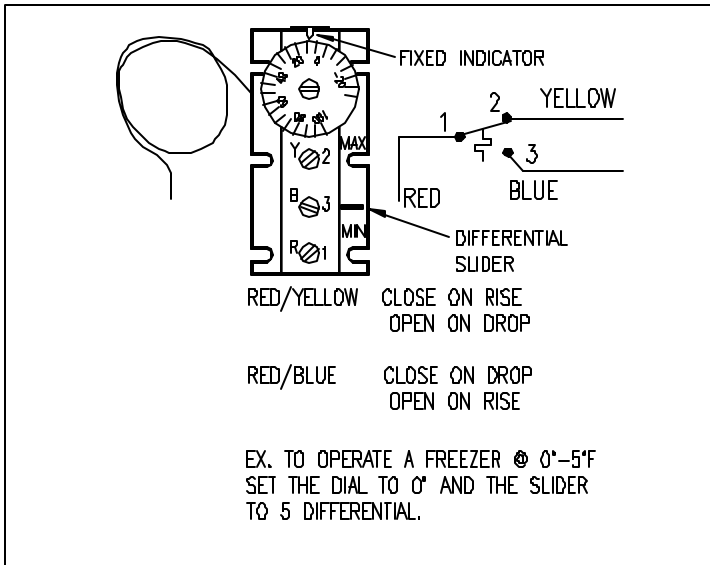


Figure 8: Typical Temperature Controls

Figure 14 shows the typical wiring diagram for a freezer equipped with electric defrost. Figure 15 shows the typical wiring diagram for a freezer equipped with hot gas defrost. Each case is provided with a wiring diagram located in the electric box that shows the exact wiring of the case.

Figure 16 shows the typical wiring of one case with the standard temperature terminating defrost control. The defrost heaters will de-energize when the defrost termination control has been satisfied.

There are many control options available for multiple case defrost systems. Wiring diagrams and instructions can be obtained by calling Zero Zone's Service Department.

External wiring should be sized according to the amperage rating stamped on the serial plate. The

Figures 10, 11, and 12. All internal wiring has been done at the factory. It has been terminated in the electrical compartment located behind the kick rail at the right end of the case. A terminal block has been used to simplify field connections.

The line side of the contactor is energized with 115 volts at all times. The 115-volt loads in the freezer are energized at all times except during defrost and during post-defrost pulldown. The 208/230 volt defrost element is OFF at all times except during defrost. The time clock is in operation at all times.

Note: All wiring must comply with the National Electrical Code and all local codes.

## DEFROSTING

### General

Periodic defrosting to keep the coil free of frost is accomplished automatically by a time clock used in conjunction with an electric, hot gas, or reduced temperature gas injection defrost system. The most reliable and efficient defrost system for a single case uses a time clock that incorporates a defrost termination device. Time clocks can be purchased that terminate on coil temperature or case coil pressure. These clocks have the ability to match the defrost time to the frost load on the coil. Coil temperature is sensed by the defrost termination thermostat supplied as standard on all Zero Zone freezers. Pressure terminating clocks generally have the pressure switch built into the time clock. A time clock can be purchased from Zero Zone or from a local refrigeration supply house.



## Electric Defrost

When the pin in the 24 hour dial reaches the TIME arrow, the clock will trip and the defrost cycle will start. At that time, the clock will stop the compressor, energize the 208/230 volt defrost heater, and energize the **normally closed** 208/230 volt contactor. This de-energizes the 115-volt fans, lights, and anti-sweat heaters.

After the defrost period, the compressor will operate. When the coil temperature reaches +5°F, the fan, light and anti-sweat heater limit thermostats will close, starting the fans, lights and anti-sweat heaters.

## Gas Defrost

Several types of gas defrost methods in conjunction with time actuated, time or temperature terminated defrost timers can be used to defrost the evaporator.

The refrigeration system designer and installer are responsible for correct line sizing for effective gas defrost and liquid return from the freezers. Sizing and component selection depend on the type of defrost, size, and location of high side refrigeration system.

Zero Zone freezers equipped for gas defrost consist of a side port, distributor and check valve for coil defrost, and a check valve and serpentine coil attached to the bottom of the pan to ensure pan and drain defrost.

Liquid and suction line connections are made inside the case, through the refrigeration access hole located in the floor pan on the left side of the freezer.

The timer starts the gas defrost cycle by energizing a solenoid, reversing valve, or directional valve. The gas is injected from the source into the suction line of the evaporator to be defrosted. The gas flows into the serpentine coil attached to the floor of the case and into the evaporator. Condensed liquid leaves the evaporator through the side port distributor, through a check valve into the liquid line.

Liquid condensed in the serpentine passes through a check valve into the liquid line. (See Figure 18 and 20)

Refer to the defrost frequency and termination recommendations that follow on Figure 9.

TEMPERATURE/PRESSURE TERMINATION			
	Reduced Temp. Gas Defrost	Hot Gas	Electric
Frequency	1	1	1
Temp.(°F)**	50	50	50
Pressure	Saturated Suction Pressure Equal to 50 ° F.		
Fail Safe Time (Min.)	40	30	54
Drain Time (Min.)	0-3	0-3	0
TIME ONLY TERMINATION			
Time (Min.)	14-22 min.	12-20 min.	40-45 min.
Drain Time	0-3	0-3	0

Figure 9: Defrost Frequency and Termination

Refrigeration technician should recheck coil condition after one week of operation to be certain that the frequency and duration of defrost is adequate for the particular store and locality. For example, if defrost voltage is below 200 volts, additional fail-safe time may be required.

Temp. termination thermostats should be wired in series for multiple evaporator installations.

## Limit Thermostat

Each freezer has factory set limit thermostats attached to the return bends of the coil on the right end of the freezer to regulate the operation of the evaporator fans, freezer lights, and anti-sweat heaters.

OPERATION OF THE LIMIT THERMOSTATS CAUSES THE EVAPORATOR FANS, FREEZER LIGHTS, AND ANTI-SWEAT HEATERS TO REMAIN OFF UNTIL THE COMPRESSOR IS OPERATING AND THE COIL TEMPERATURE IS BROUGHT BELOW THE THERMOSTAT CUT-IN SETTING (+5°F).

When the freezer first operates, the fans and lights may cycle off and on a few times until coil temperature is below +5 degrees F .



## USER INFORMATION

### Cleaning

The freezer should be thoroughly cleaned before start-up and routinely thereafter to maintain a clean appearance. Use mild detergent and warm water (never an abrasive cleaner) to wipe out the inside of the freezer. Wash down all glass doors with glass cleaner. The freezer will remain bright and sparkling with just a few minutes of cleaning each week. The case drain should be regularly cleared of debris and price tags.

Note: Do not use high-pressure water or steam to clean the interior.

### Shelf Location

The shelves are adjustable in 1-inch increments on cantilever shelf cases and 1/2-inch increments on pilaster cases and may be located in any position for best display advantage.

**Be sure shelf clips or brackets are completely seated before installing the shelf.**

### Loading the Freezer

The freezer may be loaded with merchandise after it has been operated for at least 24 hours with correct case temperature and proper control operation. While loading the shelves, leave at least 1 1/2 inch between the top of the merchandise and the shelf above it so the customer can remove the merchandise. The 1 1/2-inch space allows an air curtain on the top of the product.

### Light Switch

The light switch is located on the mullion by the hinge side right hand door. Turn the light switch off during the initial freezer temperature pull-down to prevent the freezer lights from cycling off and on. **Always turn the lights off when replacing lamps.**

## SERVICE

See Figures 17 and 18 for the typical component layout of the 30" door case. See Figures 19 and 20 for the typical component layout of the 24" door cases.

### Cart Bumper

The cart bumper must be removed to gain access to the drain clean out and electrical connection. Disassemble the bumper and black kick rail by removing the 2 or 3 metal screws located in the kick rail. The bumper assembly can be lifted up and removed from the case. The kick plate can be removed, exposing the electric tray cover and drain. (Figure 6 shows the bumper assembly)

### Evaporator

The evaporator coil, located at the rear bottom of the freezer, is factory assembled with distributor, expansion valve, and heat exchanger. To inspect the 30" door coil, remove the center or left of center coil cover. A small inspection port is located at the rear of the case. To inspect the entire 30" coil, remove the remaining coil covers and raise the evaporator cover.

The coil on the 24" door cases accessed by removing the screws from the coil cover. Rotating it at the rear integral hinge can raise the cover.

### Expansion Valve

Unless otherwise specified, an externally equalized thermostatic expansion valve with pressure limiting charge adjustable super-heat and thermal bulb is mounted to the evaporator coil. Adjust the super-



heat setting for maximum coil effectiveness. Typical super heat settings are between 6°F and 10°F. To adjust the expansion valve, remove the right end coil cover. Remove the cap from the bottom of the valve. When looking at the valve stem end, turn the valve stem counterclockwise to decrease super heat. Turn the valve stem clockwise to increase super heat. Measure the suction line temperature at the expansion valve sensing bulb and compare it to the suction temperature corresponding to the saturated pressure. Make sure that line pressure drop is taken into account.

Turn the valve stem only 1/4 turn at a time and allow sufficient time (20 to 30 minutes) for the valve to settle before making any further adjustments. Replace the valve stem cap after the valve super-heat has been adjusted. **BE CERTAIN THE VALVE STEM CAP IS WIPED DRY FIRST.**

**! CAUTION !**

**DISCONNECT POWER TO THE CASE BEFORE SERVICING ELECTRICAL COMPONENTS**

### Defrost Heater Element

The heater element is located under the coil. The electric wire leads are connected in the junction box behind the front kick rail.

### 30" Door Heater Element Removal

To remove the defrost element, remove the coil covers. Lift the inner coil cover upward and tip the fan housing forward. This will expose the coil. Remove both fan housing end brackets and center coil supports, then slide out the complete heater pan assembly from under the coil. Slowly lift the heater pan assembly between the coil and fan housing, turning it on edge while lifting.

### 24" Door Heater Element Removal

To remove the defrost element, remove the right, left, and center coil covers. Next, remove the fan housing legs and air baffle assembly fastened to the rear edge of the fan housing with sheet metal screws. Turn the

metal clips holding the heater pan from both ends of the coil end plates so they disengage the heater pan. Then slide out the complete heater pan assembly from under the coil and under the fan housing. Slowly lift the heater pan assembly between coil and fan housing, turning it on edge while lifting.

### Evaporator Fans

Air is circulated throughout the freezer with 115-volt low temperature fan motors. These motors must be operating at all times except during defrost.

### 30" Door Fan Removal

#### **Turn off power to fans.**

Remove coil cover.

Unplug fan from fan power supply plug located on the front face of the fan housing.

Remove the two mounting bolts and remove the fan assembly from the fan housing.

### 24" Door Fan Removal

#### **Turn off power to fans.**

Remove wire fan guard.

Remove fan motor mounting bracket screws.

Set motor fan assembly on floor of case.

Unplug power supply plug from fan.

Lift and rotate motor fan assembly from case.

### Lights

High output 1500 milliamp T-10 lamps are standard with 24" door and MZP freezers. These lamps are optional on MZC freezers. To ensure maximum component life, always replace with 1500 milliamp lamps. Use retainer clips and lamp shields.

To change a lamp, turn off the light switch and remove the retainer clip located between the top socket and end cap. Carefully push the lamp up into the spring-loaded lamp socket to allow the lamp to be removed from the bottom socket. (See Figure 10.) Remove the end caps and shield. **All**

**T-10 lamps must use end caps and shields.**

must be installed over the lamp. Anthony's lamp is removed by sliding the end caps off of the lamp. Detailed information is contained in the door instruction booklet.

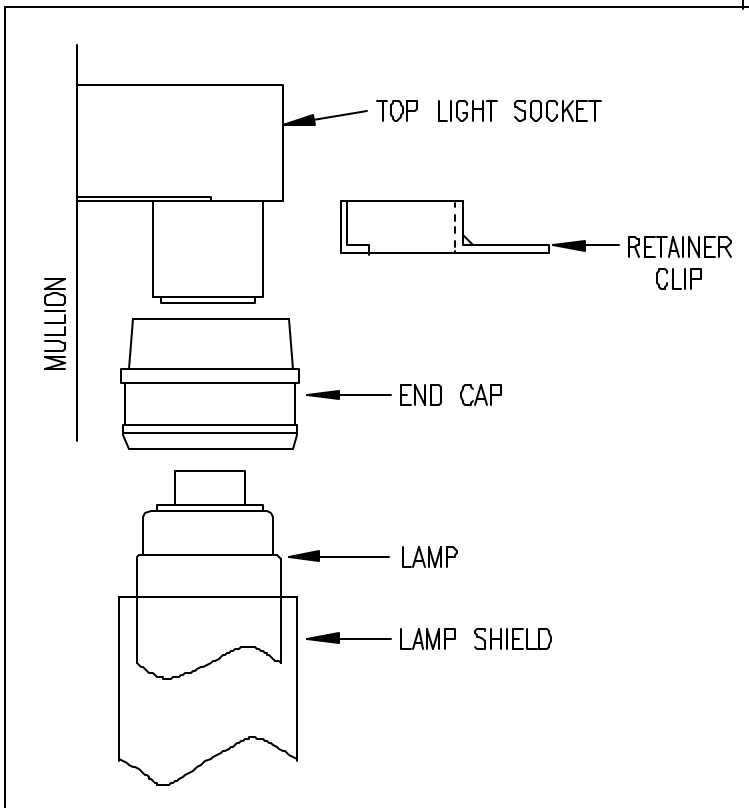


Figure 10: Socket Detail

## Ballasts

Zero Zone freezer ballasts are located either behind the kick plate or in the door mullions.

## Alternate Lighting -T8

T-8 lighting is standard on the 30" door case and optional on the 24" door freezers. Many door manufacturers provide premium lighting systems. These systems use a lens to direct light output evenly across the shelves. The lens must be removed to access the lamp. Ardc's lamp may be removed by turning it 90 degrees and sliding the lamp pins out of the lamp socket slot. The jacket



Table 1

REMOTE REACH-IN FREEZER W/ 30" X 63" DOORS MODEL RMZC30 & RMZP30 REFRIGERANT R-502, R-404a, R-507 @ -11° F EVAPORATOR FOR FROZEN FOOD									
NO. OF DOORS	FREEZER COMBINATIONS	TOTAL LENGTH W/ENDS	BTU/HR	RECOMMENDED LIQUID LINE SIZES EQUIVALENT LENGTH, FEET			RECOMMENDED SUCTION LINE SIZES EQUIVALENT LENGTH, FEET		
				50	100	150	50	100	150
2	(1) 2-DR	5'-7 1/16"	3,141	3/8	3/8	3/8	5/8	5/8	7/8
3	(1) 3-DR	8'-1 1/2"	4,544	3/8	3/8	3/8	5/8	7/8	7/8
4	(1) 4-DR	10'-7 15/16"	5,892	3/8	3/8	3/8	7/8	7/8	7/8
5	(1) 5-DR	13'-2 3/8"	7,340	3/8	3/8	3/8	7/8	7/8	1 1/8
6	(2) 3-DR	15'-10"	8,808	3/8	3/8	3/8	7/8	7/8	1 1/8
7	(1) 3-DR & (1) 4-DR	18'-4 7/16"	10,276	3/8	3/8	3/8	7/8	1 1/8	1 1/8
8	(2) 4-DR	20'-10 7/8"	11,744	3/8	3/8	1/2	7/8	1 1/8	1 1/8
9	(1) 4-DR & (1) 5-DR	23'-5 5/16"	13,212	3/8	3/8	1/2	7/8	1 1/8	1 1/8
10	(2) 5-DR	25'-11 3/4"	14,680	3/8	1/2	1/2	1 1/8	1 1/8	1 1/8
11	(1) 3-DR & (2) 4-DR	28'-7 3/8"	16,148	3/8	1/2	1/2	1 1/8	1 1/8	1 3/8
12	(3) 4-DR	31'-1 13/16"	17,616	3/8	1/2	1/2	1 1/8	1 1/8	1 3/8
13	(2) 4-DR & (1) 5-DR	33'-8 1/4"	19,084	3/8	1/2	1/2	1 1/8	1 1/8	1 3/8
14	(1) 4-DR & (2) 5-DR	36'-2 11/16"	20,552	1/2	1/2	1/2	1 1/8	1 3/8	1 3/8
15	(3) 5-DR	38'-9 1/8"	22,020	1/2	1/2	5/8	1 1/8	1 3/8	1 3/8
16	(4) 4-DR	41'-4 3/4"	23,488	1/2	1/2	5/8	1 1/8	1 3/8	1 3/8
17	(3) 4-DR & (1) 5-DR	43'-11 3/16"	24,956	1/2	1/2	5/8	1 1/8	1 3/8	1 3/8
18	(2) 4-DR & (2) 5-DR	46'-5 5/8"	26,424	1/2	5/8	5/8	1 1/8	1 3/8	1 3/8
19	(1) 4-DR & (3) 5-DR	49'-1 1/16"	27,892	1/2	5/8	5/8	1 1/8	1 3/8	1 5/8
20	(4) 5-DR	51'-6 1/2"	29,360	1/2	5/8	5/8	1 3/8	1 3/8	1 5/8
21	(4) 4-DR & (1) 5-DR	54'-2 1/8"	30,828	1/2	5/8	5/8	1 3/8	1 3/8	1 5/8
22	(3) 4-DR & (2) 5-DR	56'-8 9/16"	32,296	1/2	5/8	5/8	1 3/8	1 3/8	1 5/8
23	(2) 4-DR & (3) 5-DR	59'-3"	33,764	1/2	5/8	5/8	1 3/8	1 3/8	1 5/8
24	(1) 4-DR & (4) 5-DR	61'-9 7/16"	35,232	1/2	5/8	5/8	1 3/8	1 5/8	1 5/8
25	(5) 5-DR	64'-3 7/8"	36,700	1/2	5/8	5/8	1 3/8	1 5/8	1 5/8
26	(4) 4-DR & (2) 5-DR	66'-11 1/2"	38,168	1/2	5/8	5/8	1 3/8	1 5/8	1 5/8
27	(3) 4-DR & (3) 5-DR	69'-5 15/16"	39,636	5/8	5/8	7/8	1 3/8	1 5/8	1 5/8
28	(2) 4-DR & (4) 5-DR	72'-3/8"	41,104	5/8	5/8	7/8	1 3/8	1 5/8	1 5/8
29	(1) 4-DR & (5) 5-DR	74'-6 13/16"	42,572	5/8	5/8	7/8	1 3/8	1 5/8	1 5/8
30	(6) 5-DR	77'-1 1/4"	44,040	5/8	7/8	7/8	1 3/8	1 5/8	2 1/8

NOTE: BTU RATINGS FOR T-8 ELECTRONIC LIGHTING SYSTEM. ADD 30 BTU/DOOR FOR T-10 LIGHTING. DEDUCT 57 BTU/HR PER DOOR FOR PSC FANS. CASES DESIGNED TO OPERATE IN AN AMBIENT OF 75°F OR LOWER AND RELATIVE HUMIDITY OF 55% OR LOWER. SHADED CELL INDICATES VERTICAL SUCTION RISERS NEED TO BE ONE SIZE SMALLER THAN SIZE SHOWN



Table 2

REMOTE REACH-IN FREEZER W/ 30" X 63" DOORS MODEL RMZC30 & RMZP30 REFRIGERANT R-502, R-404a, R-507 @ -18° F EVAPORATOR FOR ICE CREAM									
NO. OF DOORS	FREEZER COMBINATIONS	TOTAL LENGTH W/ENDS	BTU/HR	RECOMMENDED LIQUID LINE SIZES EQUIVALENT LENGTH, FEET			RECOMMENDED SUCTION LINE SIZES EQUIVALENT LENGTH, FEET		
				50	100	150	50	100	150
2	(1) 2-DR	5'-7 1/16"	3,393	3/8	3/8	3/8	5/8	7/8	7/8
3	(1) 3-DR	8'-1 1/2"	4,922	3/8	3/8	3/8	7/8	7/8	7/8
4	(1) 4-DR	10'-7 15/16"	6,396	3/8	3/8	3/8	7/8	7/8	7/8
5	(1) 5-DR	13'-2 3/8"	7,970	3/8	3/8	3/8	7/8	7/8	1 1/8
6	(2) 3-DR	15'-10"	9,564	3/8	3/8	3/8	7/8	1 1/8	1 1/8
7	(1) 3-DR & (1) 4-DR	18'-4 7/16"	11,158	3/8	3/8	1/2	7/8	1 1/8	1 1/8
8	(2) 4-DR	20'-10 7/8"	12,752	3/8	3/8	1/2	1 1/8	1 1/8	1 1/8
9	(1) 4-DR & (1) 5-DR	23'-5 5/16"	14,346	3/8	1/2	1/2	1 1/8	1 1/8	1 3/8
10	(2) 5-DR	25'-11 3/4"	15,940	3/8	1/2	1/2	1 1/8	1 1/8	1 3/8
11	(1) 3-DR & (2) 4-DR	28'-7 3/8"	17,534	3/8	1/2	1/2	1 1/8	1 3/8	1 3/8
12	(3) 4-DR	31'-1 13/16"	19,128	3/8	1/2	1/2	1 1/8	1 3/8	1 3/8
13	(2) 4-DR & (1) 5-DR	33'-8 1/4"	20,722	1/2	1/2	1/2	1 1/8	1 3/8	1 3/8
14	(1) 4-DR & (2) 5-DR	36'-2 11/16"	22,316	1/2	1/2	5/8	1 1/8	1 3/8	1 3/8
15	(3) 5-DR	38'-9 1/8"	23,910	1/2	1/2	5/8	1 3/8	1 3/8	1 5/8
16	(4) 4-DR	41'-4 3/4"	25,504	1/2	1/2	5/8	1 3/8	1 3/8	1 5/8
17	(3) 4-DR & (1) 5-DR	43'-11 3/16"	27,098	1/2	5/8	5/8	1 3/8	1 3/8	1 5/8
18	(2) 4-DR & (2) 5-DR	46'-5 5/8"	28,692	1/2	5/8	5/8	1 3/8	1 3/8	1 5/8
19	(1) 4-DR & (3) 5-DR	49'-1 1/16"	30,286	1/2	5/8	5/8	1 3/8	1 5/8	1 5/8
20	(4) 5-DR	51'-6 1/2"	31,880	1/2	5/8	5/8	1 3/8	1 5/8	1 5/8
21	(4) 4-DR & (1) 5-DR	54'-2 1/8"	33,474	1/2	5/8	5/8	1 3/8	1 5/8	1 5/8
22	(3) 4-DR & (2) 5-DR	56'-8 9/16"	35,068	1/2	5/8	5/8	1 3/8	1 5/8	1 5/8
23	(2) 4-DR & (3) 5-DR	59'-3"	36,662	1/2	5/8	5/8	1 3/8	1 5/8	1 5/8
24	(1) 4-DR & (4) 5-DR	61'-9 7/16"	38,256	1/2	5/8	5/8	1 3/8	1 5/8	2 1/8
25	(5) 5-DR	64'-3 7/8"	39,850	5/8	5/8	7/8	1 3/8	1 5/8	2 1/8
26	(4) 4-DR & (2) 5-DR	66'-11 1/2"	41,444	5/8	5/8	7/8	1 3/8	1 5/8	2 1/8
27	(3) 4-DR & (3) 5-DR	69'-5 15/16"	43,038	5/8	5/8	7/8	1 5/8	1 5/8	2 1/8
28	(2) 4-DR & (4) 5-DR	72'-3/8"	44,632	5/8	5/8	7/8	1 5/8	1 5/8	2 1/8
29	(1) 4-DR & (5) 5-DR	74'-6 13/16"	46,226	5/8	5/8	7/8	1 5/8	2 1/8	2 1/8
30	(6) 5-DR	77'-1 1/4"	47,820	5/8	5/8	7/8	1 5/8	2 1/8	2 1/8

NOTE: BTU RATINGS FOR T-8 ELECTRONIC LIGHTING SYSTEM. ADD 30 BTU/DOOR FOR T-10 LIGHTING. DEDUCT 57 BTU/HR PER DOOR FOR PSC FANS. CASES DESIGNED TO OPERATE IN AN AMBIENT OF 75°F OR LOWER AND RELATIVE HUMIDITY OF 55% OR LOWER. SHADED CELL INDICATES VERTICAL SUCTION RISERS NEED TO BE ONE SIZE SMALLER THAN SIZE SHOWN



Table 3

REMOTE REACH-IN FREEZER W/ 30" X 63" DOORS MODEL RMZC30 & RMZP30 REFRIGERANT R-22 @ -11° F EVAPORATOR FOR FROZEN FOOD									
NO. OF DOORS	FREEZER COMBINATIONS	TOTAL LENGTH W/ENDS	BTU/HR	RECOMMENDED LIQUID LINE SIZES EQUIVALENT LENGTH, FEET			RECOMMENDED SUCTION LINE SIZES EQUIVALENT LENGTH, FEET		
				50	100	150	50	100	150
2	(1) 2-DR	5'-7 1/16"	3,141	3/8	3/8	3/8	5/8	5/8	5/8
3	(1) 3-DR	8'-1 1/2"	4,544	3/8	3/8	3/8	5/8	7/8	7/8
4	(1) 4-DR	10'-7 15/16"	5,892	3/8	3/8	3/8	5/8	7/8	7/8
5	(1) 5-DR	13'-2 3/8"	7,340	3/8	3/8	3/8	7/8	7/8	7/8
6	(2) 3-DR	15'-10"	8,808	3/8	3/8	3/8	7/8	7/8	7/8
7	(1) 3-DR & (1) 4-DR	18'-4 7/16"	10,276	3/8	3/8	3/8	7/8	7/8	1 1/8
8	(2) 4-DR	20'-10 7/8"	11,744	3/8	3/8	3/8	7/8	1 1/8	1 1/8
9	(1) 4-DR & (1) 5-DR	23'-5 5/16"	13,212	3/8	3/8	3/8	7/8	1 1/8	1 1/8
10	(2) 5-DR	25'-11 3/4"	14,680	3/8	3/8	3/8	7/8	1 1/8	1 1/8
11	(1) 3-DR & (2) 4-DR	28'-7 3/8"	16,148	3/8	3/8	3/8	7/8	1 1/8	1 1/8
12	(3) 4-DR	31'-1 13/16"	17,616	3/8	3/8	1/2	1 1/8	1 1/8	1 1/8
13	(2) 4-DR & (1) 5-DR	33'-8 1/4"	19,084	3/8	3/8	1/2	1 1/8	1 1/8	1 3/8
14	(1) 4-DR & (2) 5-DR	36'-2 11/16"	20,552	3/8	3/8	1/2	1 1/8	1 1/8	1 3/8
15	(3) 5-DR	38'-9 1/8"	22,020	3/8	1/2	1/2	1 1/8	1 1/8	1 3/8
16	(4) 4-DR	41'-4 3/4"	23,488	3/8	1/2	1/2	1 1/8	1 3/8	1 3/8
17	(3) 4-DR & (1) 5-DR	43'-11 3/16"	24,956	3/8	1/2	1/2	1 1/8	1 3/8	1 3/8
18	(2) 4-DR & (2) 5-DR	46'-5 5/8"	26,424	3/8	1/2	1/2	1 1/8	1 3/8	1 3/8
19	(1) 4-DR & (3) 5-DR	49'-1 1/16"	27,892	3/8	1/2	1/2	1 1/8	1 3/8	1 3/8
20	(4) 5-DR	51'-6 1/2"	29,360	3/8	1/2	1/2	1 1/8	1 3/8	1 3/8
21	(4) 4-DR & (1) 5-DR	54'-2 1/8"	30,828	1/2	1/2	1/2	1 1/8	1 3/8	1 3/8
22	(3) 4-DR & (2) 5-DR	56'-8 9/16"	32,296	1/2	1/2	5/8	1 1/8	1 3/8	1 3/8
23	(2) 4-DR & (3) 5-DR	59'-3"	33,764	1/2	1/2	5/8	1 1/8	1 3/8	1 5/8
24	(1) 4-DR & (4) 5-DR	61'-9 7/16"	35,232	1/2	1/2	5/8	1 3/8	1 3/8	1 5/8
25	(5) 5-DR	64'-3 7/8"	36,700	1/2	1/2	5/8	1 3/8	1 3/8	1 5/8
26	(4) 4-DR & (2) 5-DR	66'-11 1/2"	38,168	1/2	1/2	5/8	1 3/8	1 3/8	1 5/8
27	(3) 4-DR & (3) 5-DR	69'-5 15/16"	39,636	1/2	5/8	5/8	1 3/8	1 3/8	1 5/8
28	(2) 4-DR & (4) 5-DR	72'-3/8"	41,104	1/2	5/8	5/8	1 3/8	1 3/8	1 5/8
29	(1) 4-DR & (5) 5-DR	74'-6 13/16"	42,572	1/2	5/8	5/8	1 3/8	1 5/8	1 5/8
30	(6) 5-DR	77'-1 1/4"	44,040	1/2	5/8	5/8	1 3/8	1 5/8	1 5/8

NOTE: BTU RATINGS FOR T-8 ELECTRONIC LIGHTING SYSTEM. ADD 30 BTU/DOOR FOR T-10 LIGHTING. DEDUCT 57 BTU/HR PER DOOR FOR PSC FANS. CASES DESIGNED TO OPERATE IN AN AMBIENT OF 75°F OR LOWER AND RELATIVE HUMIDITY OF 55% OR LOWER. SHADED CELL INDICATES VERTICAL SUCTION RISERS NEED TO BE ONE SIZE SMALLER THAN SIZE SHOWN





Table 4

REMOTE REACH-IN FREEZER W/ 30" X 63" DOORS MODEL RMZC30 & RMZP30 REFRIGERANT R-22 @ -18° F EVAPORATOR FOR ICE CREAM									
NO. OF DOORS	FREEZER COMBINATIONS	TOTAL LENGTH W/ENDS	BTU/HR	RECOMMENDED LIQUID LINE SIZES EQUIVALENT LENGTH, FEET			RECOMMENDED SUCTION LINE SIZES EQUIVALENT LENGTH, FEET		
				50	100	150	50	100	150
2	(1) 2-DR	5'-7 1/16"	3,393	3/8	3/8	3/8	5/8	5/8	7/8
3	(1) 3-DR	8'-1 1/2"	4,922	3/8	3/8	3/8	5/8	7/8	7/8
4	(1) 4-DR	10'-7 15/16"	6,396	3/8	3/8	3/8	7/8	7/8	7/8
5	(1) 5-DR	13'-2 3/8"	7,970	3/8	3/8	3/8	7/8	7/8	1 1/8
6	(2) 3-DR	15'-10"	9,564	3/8	3/8	3/8	7/8	7/8	1 1/8
7	(1) 3-DR & (1) 4-DR	18'-4 7/16"	11,158	3/8	3/8	3/8	7/8	1 1/8	1 1/8
8	(2) 4-DR	20'-10 7/8"	12,752	3/8	3/8	3/8	7/8	1 1/8	1 1/8
9	(1) 4-DR & (1) 5-DR	23'-5 5/16"	14,346	3/8	3/8	3/8	7/8	1 1/8	1 1/8
10	(2) 5-DR	25'-11 3/4"	15,940	3/8	3/8	3/8	1 1/8	1 1/8	1 3/8
11	(1) 3-DR & (2) 4-DR	28'-7 3/8"	17,534	3/8	3/8	1/2	1 1/8	1 1/8	1 3/8
12	(3) 4-DR	31'-1 13/16"	19,128	3/8	3/8	1/2	1 1/8	1 1/8	1 3/8
13	(2) 4-DR & (1) 5-DR	33'-8 1/4"	20,722	3/8	3/8	1/2	1 1/8	1 3/8	1 3/8
14	(1) 4-DR & (2) 5-DR	36'-2 11/16"	22,316	3/8	1/2	1/2	1 1/8	1 3/8	1 3/8
15	(3) 5-DR	38'-9 1/8"	23,910	3/8	1/2	1/2	1 1/8	1 3/8	1 3/8
16	(4) 4-DR	41'-4 3/4"	25,504	3/8	1/2	1/2	1 1/8	1 3/8	1 3/8
17	(3) 4-DR & (1) 5-DR	43'-11 3/16"	27,098	3/8	1/2	1/2	1 1/8	1 3/8	1 3/8
18	(2) 4-DR & (2) 5-DR	46'-5 5/8"	28,692	3/8	1/2	1/2	1 1/8	1 3/8	1 5/8
19	(1) 4-DR & (3) 5-DR	49'-1 1/16"	30,286	3/8	1/2	1/2	1 3/8	1 3/8	1 5/8
20	(4) 5-DR	51'-6 1/2"	31,880	1/2	1/2	5/8	1 3/8	1 3/8	1 5/8
21	(4) 4-DR & (1) 5-DR	54'-2 1/8"	33,474	1/2	1/2	5/8	1 3/8	1 3/8	1 5/8
22	(3) 4-DR & (2) 5-DR	56'-8 9/16"	35,068	1/2	1/2	5/8	1 3/8	1 3/8	1 5/8
23	(2) 4-DR & (3) 5-DR	59'-3"	36,662	1/2	1/2	5/8	1 3/8	1 5/8	1 5/8
24	(1) 4-DR & (4) 5-DR	61'-9 7/16"	38,256	1/2	1/2	5/8	1 3/8	1 5/8	1 5/8
25	(5) 5-DR	64'-3 7/8"	39,850	1/2	5/8	5/8	1 3/8	1 5/8	1 5/8
26	(4) 4-DR & (2) 5-DR	66'-11 1/2"	41,444	1/2	5/8	5/8	1 3/8	1 5/8	1 5/8
27	(3) 4-DR & (3) 5-DR	69'-5 15/16"	43,038	1/2	5/8	5/8	1 3/8	1 5/8	1 5/8
28	(2) 4-DR & (4) 5-DR	72'-3/8"	44,632	1/2	5/8	5/8	1 3/8	1 5/8	2 1/8
29	(1) 4-DR & (5) 5-DR	74'-6 13/16"	46,226	1/2	5/8	5/8	1 3/8	1 5/8	2 1/8
30	(6) 5-DR	77'-1 1/4"	47,820	1/2	5/8	5/8	1 3/8	1 5/8	2 1/8

NOTE: BTU RATINGS FOR T-8 ELECTRONIC LIGHTING SYSTEM. ADD 30 BTU/DOOR FOR T-10 LIGHTING. DEDUCT 57 BTU/HR PER DOOR FOR PSC FANS. CASES DESIGNED TO OPERATE IN AN AMBIENT OF 75°F OR LOWER AND RELATIVE HUMIDITY OF 55% OR LOWER. SHADED CELL INDICATES VERTICAL SUCTION RISERS NEED TO BE ONE SIZE SMALLER THAN SIZE SHOWN



Table 5

REMOTE REACH-IN FREEZER W/ 24" X 63" DOORS MODEL RMZP24 REFRIGERANT R-502, R-404a, R-507 @ -14° F EVAPORATOR FOR FROZEN FOOD									
NO. OF DOORS	FREEZER COMBINATIONS	TOTAL LENGTH W/ENDS	BTU/HR	RECOMMENDED LIQUID LINE SIZES EQUIVALENT LENGTH, FEET			RECOMMENDED SUCTION LINE SIZES EQUIVALENT LENGTH, FEET		
				50	100	150	50	100	150
2	(1) 2-DR	4'-8 7/8"	3,375	3/8	3/8	3/8	5/8	5/8	7/8
3	(1) 3-DR	6'-8 5/8"	4,455	3/8	3/8	3/8	5/8	7/8	7/8
4	(1) 4-DR	8'-8 3/8"	5,530	3/8	3/8	3/8	7/8	7/8	7/8
5	(1) 5-DR	10'-8 1/8"	6,625	3/8	3/8	3/8	7/8	7/8	7/8
6	(2) 3-DR	13'-1/4"	7,950	3/8	3/8	3/8	7/8	7/8	7/8
7	(1) 3-DR & (1) 4-DR	15'-0"	9,275	3/8	3/8	3/8	7/8	7/8	1.1/8
8	(2) 4-DR	16'-11 3/4"	10,600	3/8	1/2	1/2	7/8	1.1/8	1.1/8
9	(1) 4-DR & (1) 5-DR	18'-11 1/2"	11,925	3/8	1/2	1/2	7/8	1.1/8	1.1/8
10	(2) 5-DR	20'-11 1/4"	13,250	3/8	1/2	1/2	7/8	1.1/8	1.1/8
11	(1) 3-DR & (2) 4-DR	22'-10 3/8"	14,575	3/8	1/2	1/2	7/8	1.1/8	1.1/8
12	(3) 4-DR	25'-3 1/4"	15,900	3/8	1/2	1/2	1.1/8	1.1/8	1.1/8
13	(2) 4-DR & (1) 5-DR	27'-2 7/8"	17,225	1/2	1/2	1/2	1.1/8	1.1/8	1.3/8
14	(1) 4-DR & (2) 5-DR	29'-2 5/8"	18,550	1/2	1/2	1/2	1.1/8	1.1/8	1.3/8
15	(3) 5-DR	31'-2 3/8"	19,875	1/2	1/2	1/2	1.1/8	1.1/8	1.3/8
16	(4) 4-DR	33'-6 1/2"	21,200	1/2	1/2	1/2	1.1/8	1.3/8	1.3/8
17	(3) 4-DR & (1) 5-DR	35'-6 1/4"	22,525	1/2	1/2	1/2	1.1/8	1.3/8	1.3/8
18	(2) 4-DR & (2) 5-DR	37'-6"	23,850	1/2	1/2	5/8	1.1/8	1.3/8	1.3/8
19	(1) 4-DR & (3) 5-DR	39'-5 3/4"	25,175	1/2	1/2	5/8	1.1/8	1.3/8	1.3/8
20	(4) 5-DR	41'-1/2"	26,500	1/2	1/2	5/8	1.1/8	1.3/8	1.3/8
21	(4) 4-DR & (1) 5-DR	43'-9 5/8"	27,825	1/2	1/2	5/8	1.1/8	1.3/8	1.3/8
22	(3) 4-DR & (2) 5-DR	45'-9 3/8"	29,150	1/2	5/8	5/8	1.3/8	1.3/8	1.5/8
23	(2) 4-DR & (3) 5-DR	47'-9 1/8"	30,475	1/2	5/8	5/8	1.3/8	1.3/8	1.5/8
24	(1) 4-DR & (4) 5-DR	49'-8 7/8"	31,800	1/2	5/8	5/8	1.3/8	1.3/8	1.5/8
25	(5) 5-DR	51'-8 5/8"	33,125	1/2	5/8	5/8	1.3/8	1.3/8	1.5/8
26	(4) 4-DR & (2) 5-DR	54'-3/4"	34,450	1/2	5/8	5/8	1.3/8	1.3/8	1.5/8
27	(3) 4-DR & (3) 5-DR	56'-1/2"	35,775	1/2	5/8	5/8	1.3/8	1.5/8	1.5/8
28	(2) 4-DR & (4) 5-DR	58'-1/4"	37,100	1/2	5/8	5/8	1.3/8	1.5/8	1.5/8
29	(1) 4-DR & (5) 5-DR	60'-0"	38,425	1/2	5/8	5/8	1.3/8	1.5/8	1.5/8
30	(6) 5-DR	61'-11 3/4"	39,750	1/2	5/8	5/8	1.3/8	1.5/8	1.5/8

NOTE: BTU RATINGS FOR T-8 ELECTRONIC LIGHTING SYSTEM. ADD 30 BTU/DOOR FOR T-10 LIGHTING. DEDUCT 57 BTU/HR PER DOOR FOR PSC FANS. CASES DESIGNED TO OPERATE IN AN AMBIENT OF 75°F OR LOWER AND RELATIVE HUMIDITY OF 55% OR LOWER. SHADED CELL INDICATES VERTICAL SUCTION RISERS NEED TO BE ONE SIZE SMALLER THAN SIZE SHOWN



Table 6

REMOTE REACH-IN FREEZER W/ 24" X 63" DOORS MODEL RMZP24 REFRIGERANT R-502, R-404a, R-507 @ -20° F EVAPORATOR FOR ICE CREAM									
NO. OF DOORS	FREEZER COMBINATIONS	TOTAL LENGTH W/ENDS	BTU/HR	RECOMMENDED LIQUID LINE SIZES EQUIVALENT LENGTH, FEET			RECOMMENDED SUCTION LINE SIZES EQUIVALENT LENGTH, FEET		
				50	100	150	50	100	150
2	(1) 2-DR	4'-8 7/8"	3,620	3/8	3/8	3/8	5/8	7/8	7/8
3	(1) 3-DR	6'-8 5/8"	4,775	3/8	3/8	3/8	7/8	7/8	7/8
4	(1) 4-DR	8'-8 3/8"	5,930	3/8	3/8	3/8	7/8	7/8	7/8
5	(1) 5-DR	10'-8 1/8"	7,100	3/8	3/8	3/8	7/8	7/8	1.1/8
6	(2) 3-DR	13'-1/4"	8,520	3/8	3/8	3/8	7/8	1.1/8	1.1/8
7	(1) 3-DR & (1) 4-DR	15'-0"	9,940	3/8	1/2	1/2	7/8	1.1/8	1.1/8
8	(2) 4-DR	16'-11 3/4"	11,360	3/8	1/2	1/2	7/8	1.1/8	1.1/8
9	(1) 4-DR & (1) 5-DR	18'-11 1/2"	12,780	3/8	1/2	1/2	1.1/8	1.1/8	1.1/8
10	(2) 5-DR	20'-11 1/4"	14,200	3/8	1/2	1/2	1.1/8	1.1/8	1.3/8
11	(1) 3-DR & (2) 4-DR	22'-10 3/8"	15,620	3/8	1/2	1/2	1.1/8	1.1/8	1.3/8
12	(3) 4-DR	25'-3 1/4"	17,040	1/2	1/2	1/2	1.1/8	1.3/8	1.3/8
13	(2) 4-DR & (1) 5-DR	27'-2 7/8"	18,460	1/2	1/2	1/2	1.1/8	1.3/8	1.3/8
14	(1) 4-DR & (2) 5-DR	29'-2 5/8"	19,880	1/2	1/2	1/2	1.1/8	1.3/8	1.3/8
15	(3) 5-DR	31'-2 3/8"	21,300	1/2	1/2	1/2	1.1/8	1.3/8	1.3/8
16	(4) 4-DR	33'-6 1/2"	22,720	1/2	1/2	5/8	1.1/8	1.3/8	1.3/8
17	(3) 4-DR & (1) 5-DR	35'-6 1/4"	24,140	1/2	1/2	5/8	1.3/8	1.3/8	1.5/8
18	(2) 4-DR & (2) 5-DR	37'-6"	25,560	1/2	1/2	5/8	1.3/8	1.3/8	1.5/8
19	(1) 4-DR & (3) 5-DR	39'-5 3/4"	26,980	1/2	1/2	5/8	1.3/8	1.3/8	1.5/8
20	(4) 5-DR	41'-1/2"	28,400	1/2	5/8	5/8	1.3/8	1.3/8	1.5/8
21	(4) 4-DR & (1) 5-DR	43'-9 5/8"	29,820	1/2	5/8	5/8	1.3/8	1.5/8	1.5/8
22	(3) 4-DR & (2) 5-DR	45'-9 3/8"	31,240	1/2	5/8	5/8	1.3/8	1.5/8	1.5/8
23	(2) 4-DR & (3) 5-DR	47'-9 1/8"	32,660	1/2	5/8	5/8	1.3/8	1.5/8	1.5/8
24	(1) 4-DR & (4) 5-DR	49'-8 7/8"	34,080	1/2	5/8	5/8	1.3/8	1.5/8	1.5/8
25	(5) 5-DR	51'-8 5/8"	35,500	1/2	5/8	5/8	1.3/8	1.5/8	1.5/8
26	(4) 4-DR & (2) 5-DR	54'-3/4"	36,920	1/2	5/8	5/8	1.3/8	1.5/8	1.5/8
27	(3) 4-DR & (3) 5-DR	56'-1/2"	38,340	1/2	5/8	5/8	1.3/8	1.5/8	2.1/8
28	(2) 4-DR & (4) 5-DR	58'-1/4"	39,760	1/2	5/8	5/8	1.3/8	1.5/8	2.1/8
29	(1) 4-DR & (5) 5-DR	60'-0"	41,180	5/8	5/8	5/8	1.3/8	1.5/8	2.1/8
30	(6) 5-DR	61'-11 3/4"	42,600	5/8	5/8	7/8	1.5/8	1.5/8	2.1/8

NOTE: BTU RATINGS FOR T-8 ELECTRONIC LIGHTING SYSTEM. ADD 30 BTU/DOOR FOR T-10 LIGHTING. DEDUCT 57 BTU/HR PER DOOR FOR PSC FANS. CASES DESIGNED TO OPERATE IN AN AMBIENT OF 75°F OR LOWER AND RELATIVE HUMIDITY OF 55% OR LOWER. SHADED CELL INDICATES VERTICAL SUCTION RISERS NEED TO BE ONE SIZE SMALLER THAN SIZE SHOWN



Table 7

**REMOTE REACH-IN FREEZER W/ 24" X 63" DOORS  
MODEL RMZP24  
REFRIGERANT R-22 @ -14° F  
EVAPORATOR FOR FROZEN FOOD**

NO. OF DOORS	FREEZER COMBINATIONS	TOTAL LENGTH W/ENDS	BTU/HR	RECOMMENDED LIQUID LINE SIZES EQUIVALENT LENGTH, FEET			RECOMMENDED SUCTION LINE SIZES EQUIVALENT LENGTH, FEET		
				50	100	150	50	100	150
2	(1) 2-DR	4'-8 7/8"	3,375	3/8	3/8	3/8	5/8	5/8	5/8
3	(1) 3-DR	6'-8 5/8"	4,455	3/8	3/8	3/8	5/8	7/8	7/8
4	(1) 4-DR	8'-8 3/8"	5,530	3/8	3/8	3/8	5/8	7/8	7/8
5	(1) 5-DR	10'-8 1/8"	6,625	3/8	3/8	3/8	7/8	7/8	7/8
6	(2) 3-DR	13'-1/4"	7,950	3/8	3/8	3/8	7/8	7/8	7/8
7	(1) 3-DR & (1) 4-DR	15'-0"	9,275	3/8	3/8	3/8	7/8	7/8	7/8
8	(2) 4-DR	16'-11 3/4"	10,600	3/8	3/8	3/8	7/8	7/8	1.1/8
9	(1) 4-DR & (1) 5-DR	18'-11 1/2"	11,925	3/8	3/8	1/2	7/8	7/8	1.1/8
10	(2) 5-DR	20'-11 1/4"	13,250	3/8	3/8	1/2	7/8	1.1/8	1.1/8
11	(1) 3-DR & (2) 4-DR	22'-10 3/8"	14,575	3/8	1/2	1/2	7/8	1.1/8	1.1/8
12	(3) 4-DR	25'-3 1/4"	15,900	3/8	1/2	1/2	1.1/8	1.1/8	1.1/8
13	(2) 4-DR & (1) 5-DR	27'-2 7/8"	17,225	3/8	1/2	1/2	1.1/8	1.1/8	1.1/8
14	(1) 4-DR & (2) 5-DR	29'-2 5/8"	18,550	3/8	1/2	1/2	1.1/8	1.1/8	1.1/8
15	(3) 5-DR	31'-2 3/8"	19,875	1/2	1/2	1/2	1.1/8	1.1/8	1.3/8
16	(4) 4-DR	33'-6 1/2"	21,200	1/2	1/2	1/2	1.1/8	1.1/8	1.3/8
17	(3) 4-DR & (1) 5-DR	35'-6 1/4"	22,525	1/2	1/2	1/2	1.1/8	1.1/8	1.3/8
18	(2) 4-DR & (2) 5-DR	37'-6"	23,850	1/2	1/2	1/2	1.1/8	1.1/8	1.3/8
19	(1) 4-DR & (3) 5-DR	39'-5 3/4"	25,175	1/2	1/2	1/2	1.1/8	1.3/8	1.3/8
20	(4) 5-DR	41'-1/2"	26,500	1/2	1/2	1/2	1.1/8	1.3/8	1.3/8
21	(4) 4-DR & (1) 5-DR	43'-9 5/8"	27,825	1/2	1/2	1/2	1.1/8	1.3/8	1.3/8
22	(3) 4-DR & (2) 5-DR	45'-9 3/8"	29,150	1/2	1/2	1/2	1.1/8	1.3/8	1.3/8
23	(2) 4-DR & (3) 5-DR	47'-9 1/8"	30,475	1/2	1/2	1/2	1.3/8	1.3/8	1.3/8
24	(1) 4-DR & (4) 5-DR	49'-8 7/8"	31,800	1/2	1/2	1/2	1.3/8	1.3/8	1.3/8
25	(5) 5-DR	51'-8 5/8"	33,125	1/2	1/2	1/2	1.3/8	1.3/8	1.3/8
26	(4) 4-DR & (2) 5-DR	54'-3/4"	34,450	1/2	1/2	1/2	1.3/8	1.3/8	1.3/8
27	(3) 4-DR & (3) 5-DR	56'-1/2"	35,775	1/2	1/2	5/8	1.3/8	1.3/8	1.5/8
28	(2) 4-DR & (4) 5-DR	58'-1/4"	37,100	1/2	1/2	5/8	1.3/8	1.3/8	1.5/8
29	(1) 4-DR & (5) 5-DR	60'-0"	38,425	1/2	1/2	5/8	1.3/8	1.3/8	1.5/8
30	(6) 5-DR	61'-11 3/4"	39,750	1/2	1/2	5/8	1.3/8	1.3/8	1.5/8

NOTE: BTU RATINGS FOR T-8 ELECTRONIC LIGHTING SYSTEM. ADD 30 BTU/DOOR FOR T-10 LIGHTING. DEDUCT 57 BTU/HR PER DOOR FOR PSC FANS. CASES DESIGNED TO OPERATE IN AN AMBIENT OF 75°F OR LOWER AND RELATIVE HUMIDITY OF 55% OR LOWER. SHADED CELL INDICATES VERTICAL SUCTION RISERS NEED TO BE ONE SIZE SMALLER THAN SIZE SHOWN



Table 8

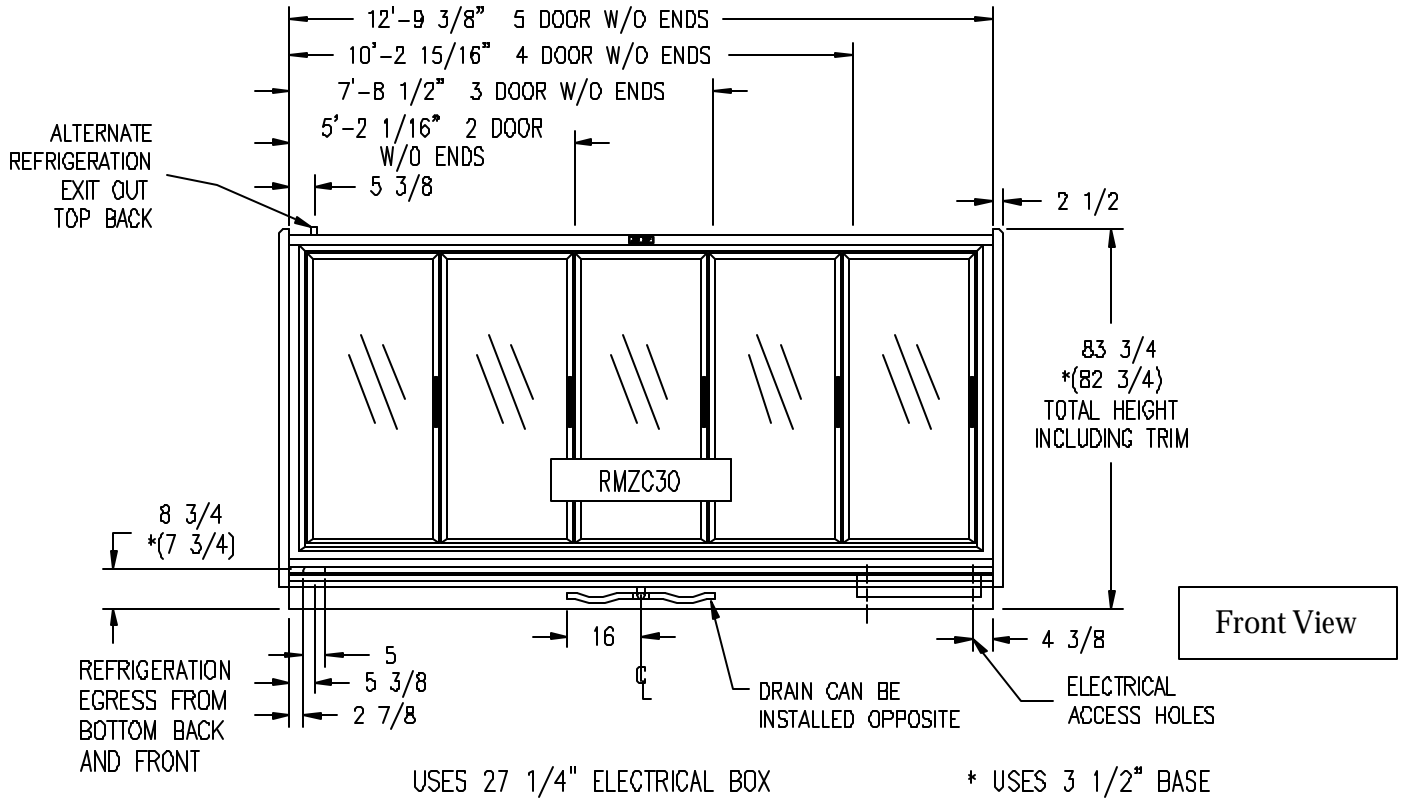
REMOTE REACH-IN FREEZER W/ 24" X 63" DOORS MODEL RMZP24 REFRIGERANT R-22 @ -20° F EVAPORATOR FOR ICE CREAM									
NO. OF DOORS	FREEZER COMBINATIONS	TOTAL LENGTH W/ENDS	BTU/HR	RECOMMENDED LIQUID LINE SIZES EQUIVALENT LENGTH, FEET			RECOMMENDED SUCTION LINE SIZES EQUIVALENT LENGTH, FEET		
				50	100	150	50	100	150
2	(1) 2-DR	4'-8 7/8"	3,620	3/8	3/8	3/8	5/8	7/8	7/8
3	(1) 3-DR	6'-8 5/8"	4,775	3/8	3/8	3/8	5/8	7/8	7/8
4	(1) 4-DR	8'-8 3/8"	5,930	3/8	3/8	3/8	7/8	7/8	7/8
5	(1) 5-DR	10'-8 1/8"	7,100	3/8	3/8	3/8	7/8	7/8	7/8
6	(2) 3-DR	13'-1/4"	8,520	3/8	3/8	3/8	7/8	7/8	1.1/8
7	(1) 3-DR & (1) 4-DR	15'-0"	9,940	3/8	3/8	1/2	7/8	1.1/8	1.1/8
8	(2) 4-DR	16'-11 3/4"	11,360	3/8	3/8	1/2	7/8	1.1/8	1.1/8
9	(1) 4-DR & (1) 5-DR	18'-11 1/2"	12,780	3/8	3/8	1/2	7/8	1.1/8	1.1/8
10	(2) 5-DR	20'-11 1/4"	14,200	3/8	1/2	1/2	7/8	1.1/8	1.1/8
11	(1) 3-DR & (2) 4-DR	22'-10 3/8"	15,620	3/8	1/2	1/2	1.1/8	1.1/8	1.1/8
12	(3) 4-DR	25'-3 1/4"	17,040	3/8	1/2	1/2	1.1/8	1.1/8	1.3/8
13	(2) 4-DR & (1) 5-DR	27'-2 7/8"	18,460	1/2	1/2	1/2	1.1/8	1.1/8	1.3/8
14	(1) 4-DR & (2) 5-DR	29'-2 5/8"	19,880	1/2	1/2	1/2	1.1/8	1.3/8	1.3/8
15	(3) 5-DR	31'-2 3/8"	21,300	1/2	1/2	1/2	1.1/8	1.3/8	1.3/8
16	(4) 4-DR	33'-6 1/2"	22,720	1/2	1/2	1/2	1.1/8	1.3/8	1.3/8
17	(3) 4-DR & (1) 5-DR	35'-6 1/4"	24,140	1/2	1/2	1/2	1.1/8	1.3/8	1.3/8
18	(2) 4-DR & (2) 5-DR	37'-6"	25,560	1/2	1/2	1/2	1.1/8	1.3/8	1.3/8
19	(1) 4-DR & (3) 5-DR	39'-5 3/4"	26,980	1/2	1/2	1/2	1.1/8	1.3/8	1.3/8
20	(4) 5-DR	41'-1/2"	28,400	1/2	1/2	1/2	1.1/8	1.3/8	1.3/8
21	(4) 4-DR & (1) 5-DR	43'-9 5/8"	29,820	1/2	1/2	1/2	1.3/8	1.3/8	1.5/8
22	(3) 4-DR & (2) 5-DR	45'-9 3/8"	31,240	1/2	1/2	1/2	1.3/8	1.3/8	1.5/8
23	(2) 4-DR & (3) 5-DR	47'-9 1/8"	32,660	1/2	1/2	1/2	1.3/8	1.3/8	1.5/8
24	(1) 4-DR & (4) 5-DR	49'-8 7/8"	34,080	1/2	1/2	5/8	1.3/8	1.3/8	1.5/8
25	(5) 5-DR	51'-8 5/8"	35,500	1/2	1/2	5/8	1.3/8	1.3/8	1.5/8
26	(4) 4-DR & (2) 5-DR	54'-3/4"	36,920	1/2	1/2	5/8	1.3/8	1.5/8	1.5/8
27	(3) 4-DR & (3) 5-DR	56'-1/2"	38,340	1/2	1/2	5/8	1.3/8	1.5/8	1.5/8
28	(2) 4-DR & (4) 5-DR	58'-1/4"	39,760	1/2	1/2	5/8	1.3/8	1.5/8	1.5/8
29	(1) 4-DR & (5) 5-DR	60'-0"	41,180	1/2	5/8	5/8	1.3/8	1.5/8	1.5/8
30	(6) 5-DR	61'-11 3/4"	42,600	1/2	5/8	5/8	1.3/8	1.5/8	1.5/8

NOTE: BTU RATINGS FOR T-8 ELECTRONIC LIGHTING SYSTEM. ADD 30 BTU/DOOR FOR T-10 LIGHTING. DEDUCT 57 BTU/HR PER DOOR FOR PSC FANS. CASES DESIGNED TO OPERATE IN AN AMBIENT OF 75°F OR LOWER AND RELATIVE HUMIDITY OF 55% OR LOWER. SHADED CELL INDICATES VERTICAL SUCTION RISERS NEED TO BE ONE SIZE SMALLER THAN SIZE SHOWN

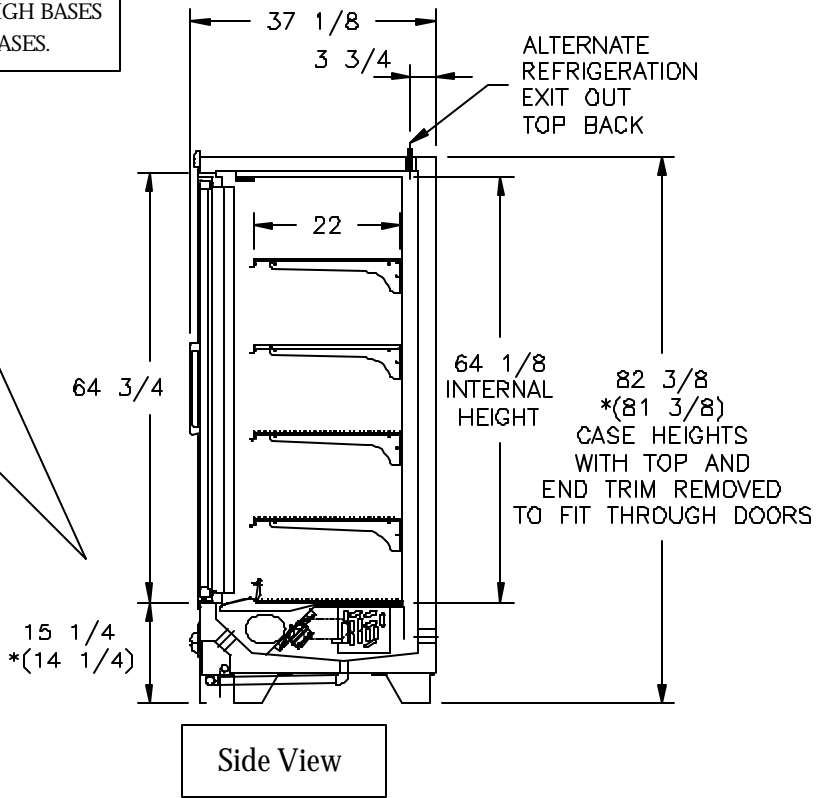
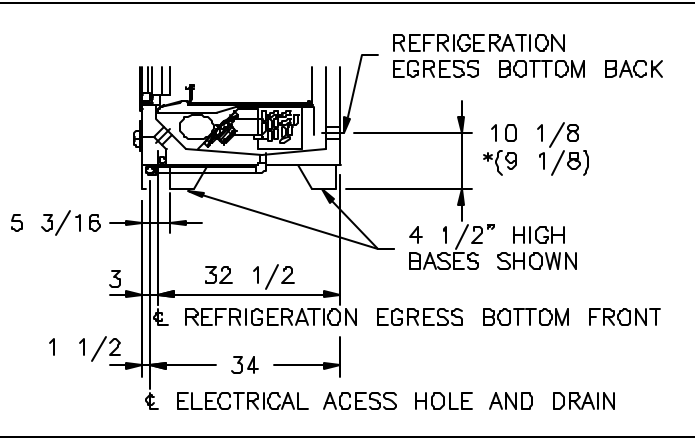


Figure 10

# RMZC30 SPECIFICATION SHEET



\* NOTE: CASE DIMENSIONS SHOWN REFLECT STANDARD 4-1/2" HIGH BASES  
 DIMENSIONS SHOWN IN (PARENTHESIS) REFLECT 3-1/2" BASES.



Zero Zone, Inc. • 110 N. Oakridge Dr.  
 North Prairie, WI 53153-9792  
 1-800-247-4496 • FAX: 1-414-392-6450  
 www.zero-zone.com

All specifications are subject to change without notice.

Figure 10



# RMZC30 SPECIFICATION SHEET

REFRIGERANT CONNECTIONS SIZES FOR ELECTRIC DEFROST			
MODEL NUMBER	SUCTION LINE O.D.	LIQUID LINE O.D.	SUCTION LINE O.D. FOR REFRIGERATION OUT TOP BACK
2RMZC30	7/8	3/8	5/8
3RMZC30	7/8	3/8	5/8
4RMZC30	7/8	3/8	7/8
5RMZC30	7/8	3/8	7/8

REFRIGERANT CONNECTIONS SIZES FOR HOT GAS DEFROST			
MODEL NUMBER	SUCTION LINE O.D.	LIQUID LINE O.D.	SUCTION LINE O.D. FOR REFRIGERATION OUT TOP BACK
2RMZC30	7/8	1/2	5/8
3RMZC30	7/8	1/2	5/8
4RMZC30	7/8	1/2	7/8
5RMZC30	7/8	1/2	7/8

ELECTRICAL SPECS. BY DOOR MANUFACTURER						
MODEL NUMBER	FANS AMPS	T-8 LIGHTS AMPS	T-10 LIGHT AMPS ONE END*	T-10 LIGHT AMPS BOTH ENDS	ANTI-SWEAT HEATERS	DEFROST HEATER AMPS 208V/1/60HZ.
<b>ANTHONY DOORS</b>						
2RMZC30	0.68	1.45	1.5	2.25	4.42	6.73
3RMZC30	1.02	1.94	2.25	3	6.44	10.09
4RMZC30	1.36	2.42	3	3.75	8.32	13.46
5RMZC30	1.70	2.91	3.75	4.5	10.16	16.83
<b>ARDCO DOORS</b>						
2RMZC30	0.68	1.89	1.5	2.25	5.52	6.73
3RMZC30	1.02	2.34	2.25	3	7.83	10.09
4RMZC30	1.36	3.06	3	3.75	9.84	13.46
5RMZC30	1.70	3.51	3.75	4.5	12.05	16.83
SUBTRACT 0.19 AMPS PER DOOR FOR PSC FAN MOTORS *STANDARD FOR CASE IN A LINE-UP VOLTAGE: 115 VOLTS 1 PHASE 60 HZ.						

CAPACITY SPECIFICATIONS		
CASE SIZE	CAPACITIES	
	USABLE CUBIC FEET	VERTICAL SURFACE SQUARE FOOTAGE
2RMZC30	51	28
3RMZC30	76	41
4RMZC30	100	55
5RMZC30	125	68

CASE SIZE	WEIGHT IN POUNDS*
2RMZC30	788
3RMZC30	1,096
4RMZC30	1,468
5RMZC30	1,870

\*WEIGHT BASED ON UNCRATED CASES WITHOUT ENDS, AND FULLY SHELVED. SINGLE END WEIGHT: 54 POUNDS

BTU/HR ENERGY REQUIREMENTS: FROZEN FOOD -11°F EVAPORATOR (-5°F AVERAGE PRODUCT TEMPERATURE) ICE CREAM -18°F EVAPORATOR (-12°F AVERAGE PRODUCT TEMPERATURE)			
MODEL NUMBER	BTU/HR @ -11°F	BTU/HR @ -18°F	BTU/HR RATING BASED ON T-8 LIGHTING AND PARALLEL RACK SYSTEM. MULTIPLY BY 1.04 FOR CONVENTIONAL SYSTEM.
2RMZC30	3,141	3,393	ADD 30 BTU/HR PER DOOR FOR T-10 LIGHTING CASE DESIGNED TO OPERATE IN AN AMBIENT OF 75°F OR LOWER AND RELATIVE HUMIDITY OF 55% OR LOWER. DEDUCT 57 BTU/HR/DOOR FOR PSC FAN MOTORS
3RMZC30	4,544	4,922	
4RMZC30	5,892	6,396	
5RMZC30	7,340	7,970	

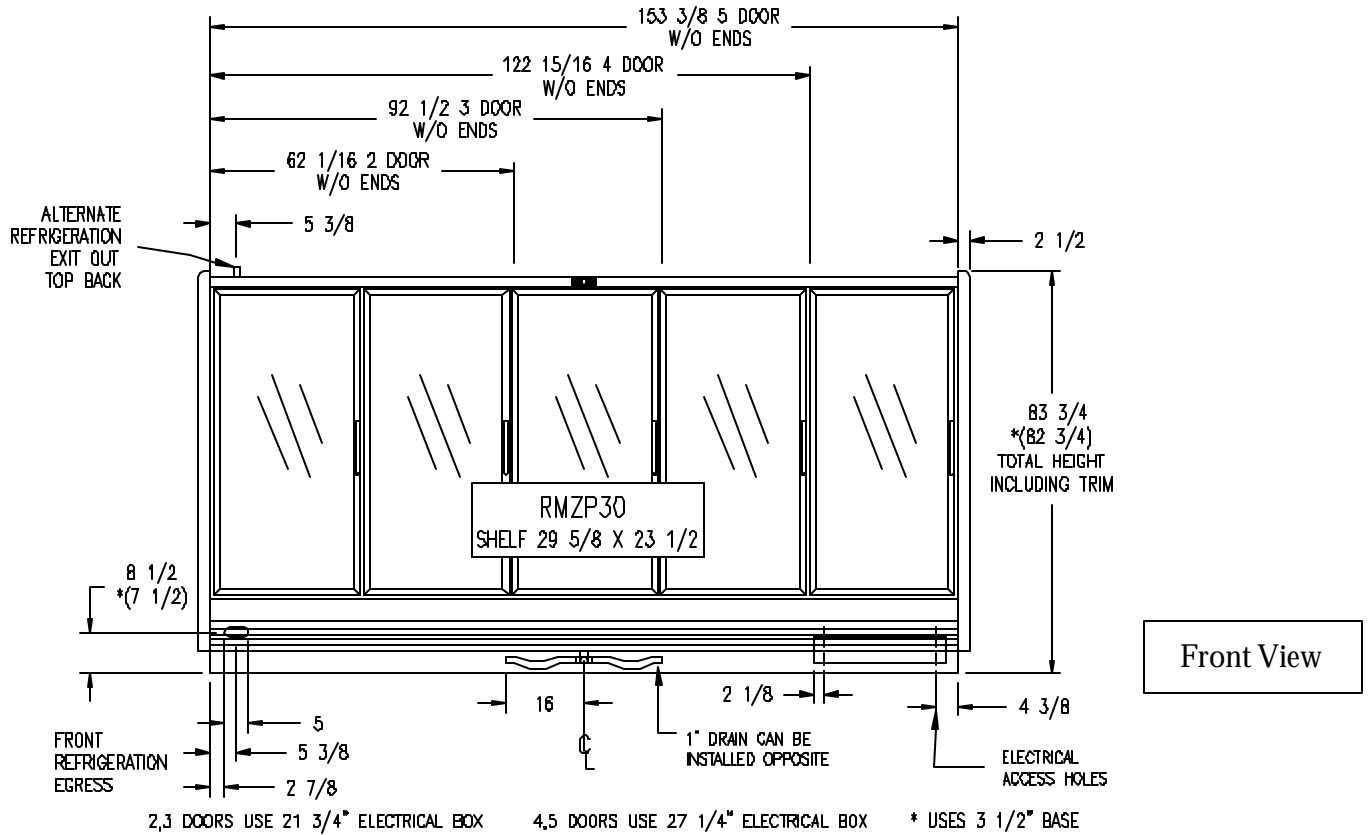
Zero Zone, Inc. • 110 N. Oakridge Dr.  
North Prairie, WI 53153-9792  
1-800-247-4496 • FAX: 1-414-392-6450  
www.zero-zone.com

All specifications are subject to change without notice.



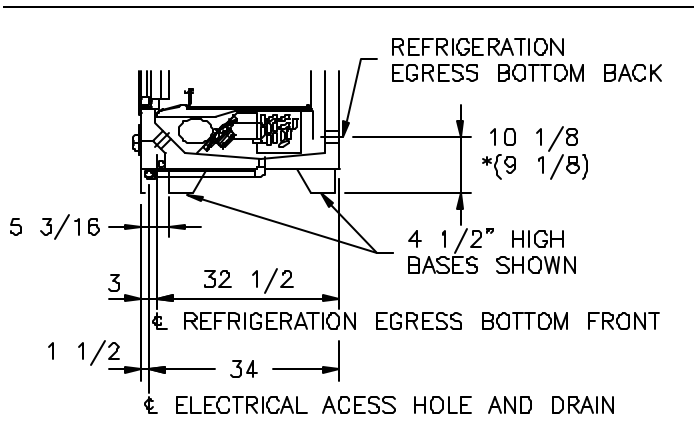
Figure 11

# RMZP30 SPECIFICATION SHEET

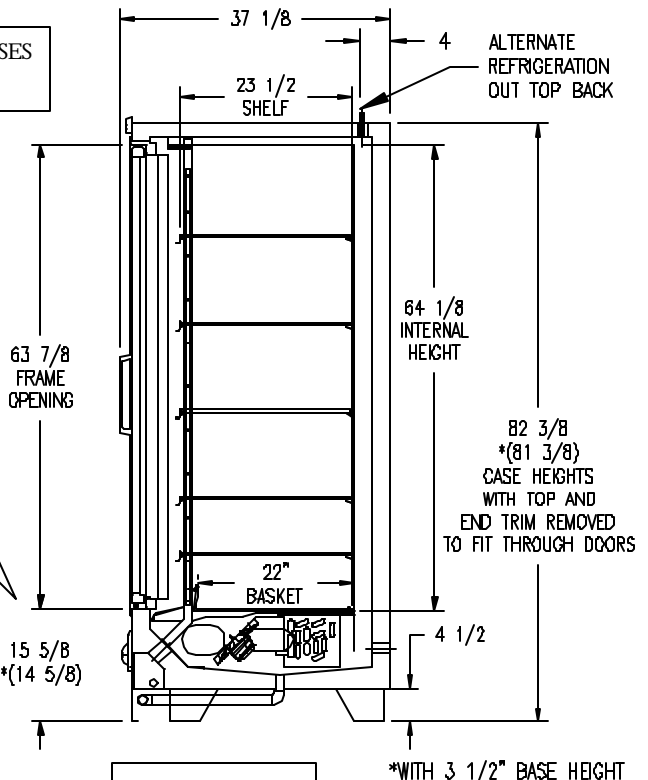


Front View

\* NOTE: CASE DIMENSIONS SHOWN REFLECT STANDARD 4-1/2" HIGH BASES  
 DIMENSIONS SHOWN IN PARENTHESIS REFLECT 3-1/2" BASES.



Partial Side View (Bottom)



Side View

Zero Zone, Inc. • 110 N. Oakridge Dr.  
 North Prairie, WI 53153-9792  
 1-800-247-4496 • FAX: 1-262-392-6450  
 www.zero-zone.com

All specifications are subject to change without notice.





Figure 11

# RMZP30 SPECIFICATION SHEET

REFRIGERANT CONNECTIONS SIZES FOR ELECTRIC DEFROST			
MODEL NUMBER	SUCTION LINE O.D.	LIQUID LINE O.D.	SUCTION LINE O.D. FOR REFRIGERATION OUT TOP BACK
2RMZP30	7/8	3/8	5/8
3RMZP30	7/8	3/8	5/8
4RMZP30	7/8	3/8	7/8
5RMZP30	7/8	3/8	7/8

REFRIGERANT CONNECTIONS SIZES FOR HOT GAS DEFROST			
MODEL NUMBER	SUCTION LINE O.D.	LIQUID LINE O.D.	SUCTION LINE O.D. FOR REFRIGERATION OUT TOP BACK
2RMZP30	7/8	1/2	5/8
3RMZP30	7/8	1/2	5/8
4RMZP30	7/8	1/2	7/8
5RMZP30	7/8	1/2	7/8

ELECTRICAL SPECS. BY DOOR MANUFACTURER						
MODEL NUMBER	FANS AMPS	T-8 LIGHTS AMPS	T-10 LIGHT AMPS ONE END*	T-10 LIGHT AMPS BOTH ENDS	ANTI-SWEAT HEATERS	DEFROST HEATER AMPS 208V/1/60HZ.
<b>ANTHONY DOORS</b>						
2RMZP30	0.68	1.45	1.5	2.25	4.42	6.73
3RMZP30	1.02	1.94	2.25	3	6.44	10.09
4RMZP30	1.36	2.42	3	3.75	8.32	13.46
5RMZP30	1.70	2.91	3.75	4.5	10.16	16.83
<b>ARDCO DOORS</b>						
2RMZP30	0.68	1.89	1.5	2.25	5.52	6.73
3RMZP30	1.02	2.34	2.25	3	7.83	10.09
4RMZP30	1.36	3.06	3	3.75	9.84	13.46
5RMZP30	1.70	3.51	3.75	4.5	12.05	16.83
SUBTRACT 0.19 AMPS PER DOOR FOR PSC FAN MOTORS *STANDARD FOR CASE IN A LINE-UP VOLTAGE: 115 VOLTS 1 PHASE 60 HZ.						

CAPACITY SPECIFICATIONS		
CASE SIZE	CAPACITIES	
	USABLE CUBIC FEET	VERTICAL SURFACE SQUARE FOOTAGE
2RMZP30	54	28
3RMZP30	81	41
4RMZP30	107	55
5RMZP30	134	68

CASE SIZE	WEIGHT IN POUNDS*
2RMZP30	721
3RMZP30	1,043
4RMZP30	1,406
5RMZP30	1,876

\*WEIGHT BASED ON UNCRATED CASES WITHOUT ENDS, AND FULLY SHELVED. SINGLE END WEIGHT: 54 POUNDS

BTU/HR ENERGY REQUIREMENTS: FROZEN FOOD -11°F EVAPORATOR (-3°F AVERAGE PRODUCT TEMPERATURE) ICE CREAM -18°F EVAPORATOR (-10°F AVERAGE PRODUCT TEMPERATURE)			
MODEL NUMBER	BTU/HR @ -11°F	BTU/HR @ -18°F	BTU/HR RATING BASED ON T-8 LIGHTING AND PARALLEL RACK SYSTEM. MULTIPLY BY 1.04 FOR CONVENTIONAL SYSTEM.
2RMZP30	3,141	3,393	ADD 30 BTU/HR PER DOOR FOR T-10 LIGHTING CASE DESIGNED TO OPERATE IN AN AMBIENT OF 75°F OR LOWER AND RELATIVE HUMIDITY OF 55% OR LOWER. DEDUCT 57 BTU/HR/DOOR FOR PSC FAN MOTORS
3RMZP30	4,544	4,922	
4RMZP30	5,892	6,396	
5RMZP30	7,340	7,970	

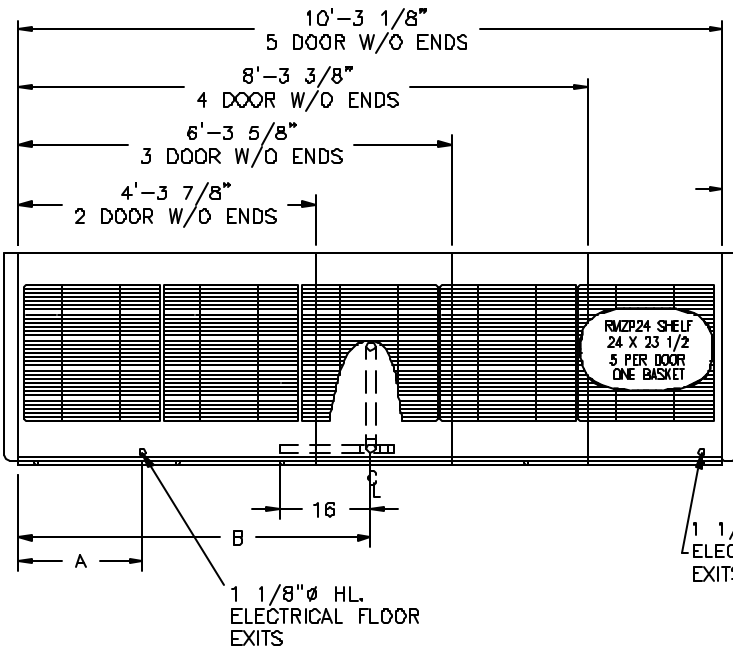
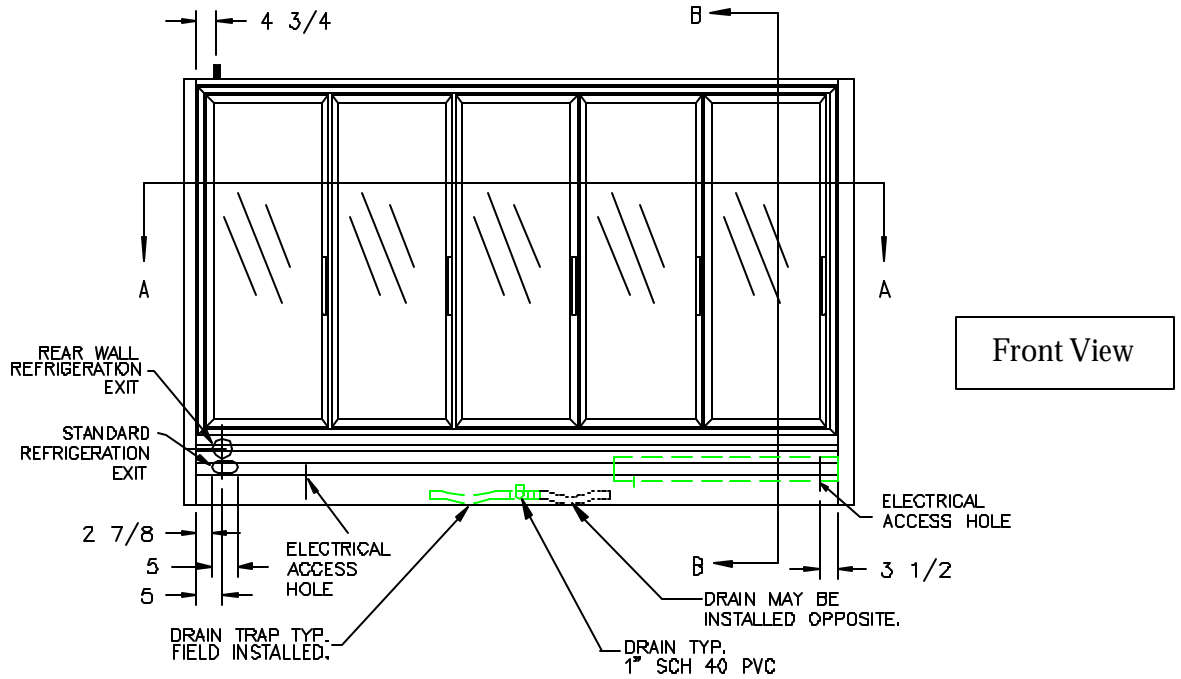
Zero Zone, Inc. • 110 N. Oakridge Dr.  
North Prairie, WI 53153-9792  
1-800-247-4496 • FAX: 1-262-392-6450  
www.zero-zone.com

All specifications are subject to change without notice.

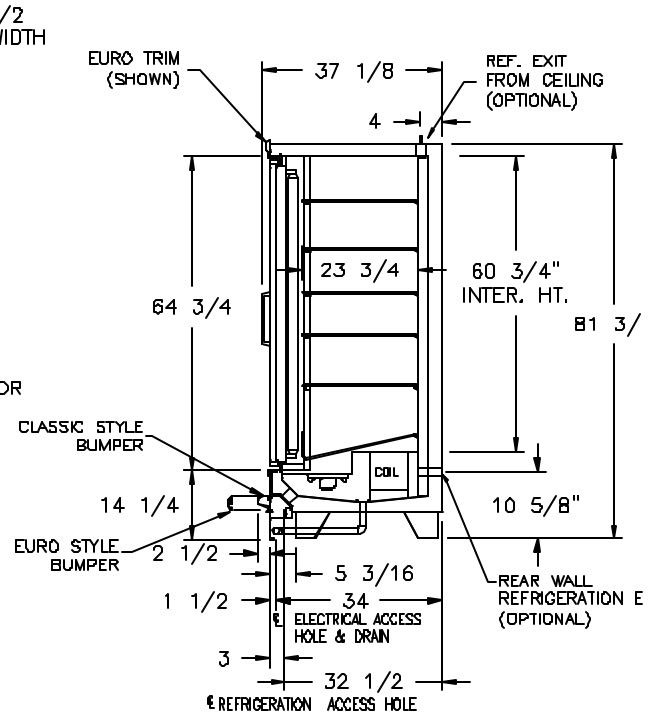


Figure 12

# RMZP24 SPECIFICATION SHEET



Top View  
Shown in Section  
5RMZP24



Side View

Zero Zone Inc. • 110 N. Oakridge Dr.  
North Prairie, WI 53153-9792  
1-800-247-4496 • FAX: 1-262-392-6450  
www.zero-zone.com

All specifications are subject to change without notice.



# RMZP24 SPECIFICATION SHEET

RMZP24 CAPACITY SPECIFICATIONS			
CASE SIZE	SHELVING 24 X 23 1/2"	CUBIC FEET CAPACITY	WEIGHT*
	NET SQ. FT.	NET CUBIC FT.	POUNDS
2	47.0	42.9	567
3	70.6	62.5	820
4	94.1	82.1	1073
5	117.6	101.7	1477

WEIGHT BASED ON UNCRATED CASES WITHOUT ENDS, AND FULLY SHELVED  
SINGLE END WEIGHT: 54#

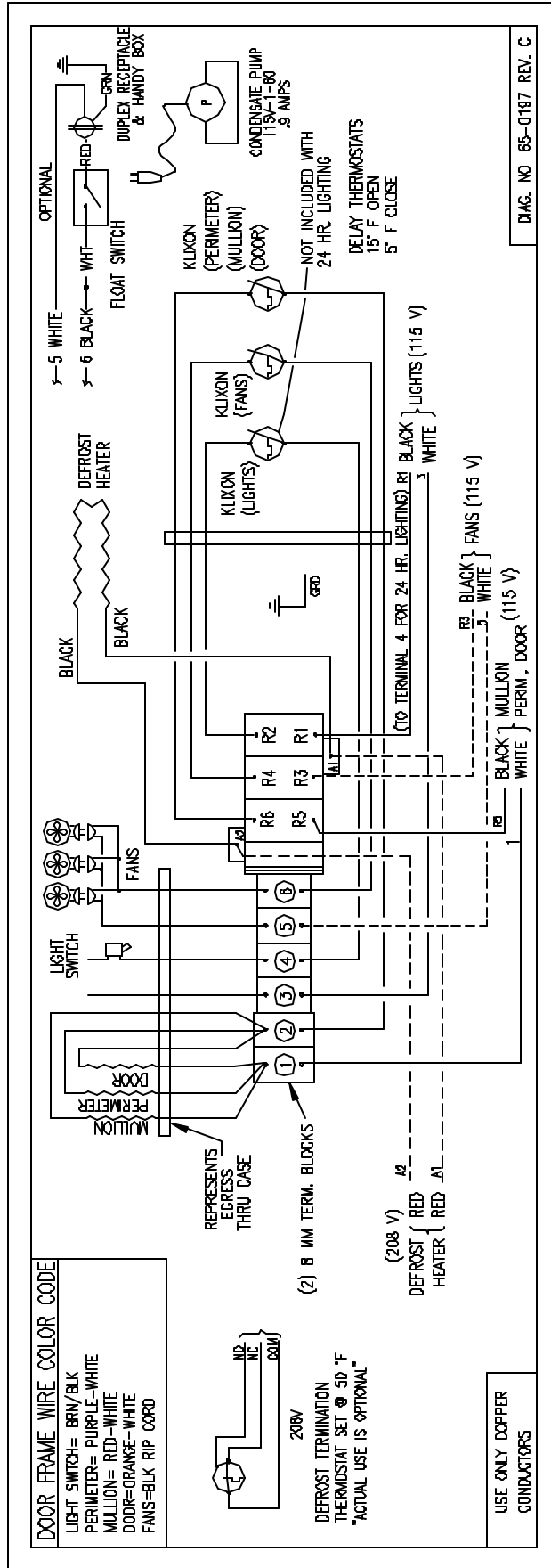
REFRIGERANT CONNECTIONS HOT GAS DEFROST			
MODEL	TOP SUCTION LINE O.D.	STANDARD BOTTOM SUCTION LINE O.D.	BOTTOM & TOP LIQUID LINE O.D.
2RMZP24	5/8	7/8	3/8
3RMZP24	7/8	7/8	3/8
4RMZP24	7/8	7/8	1/2
5RMZP24	1 1/8	1 1/8	1/2

REFRIGERANT CONNECTIONS ELECTRIC DEFROST			
MODEL	TOP SUCTION LINE O.D.	STANDARD BOTTOM SUCTION LINE O.D.	BOTTOM & TOP LIQUID LINE O.D.
2RMZP24	5/8	7/8	3/8
3RMZP24	7/8	7/8	3/8
4RMZP24	7/8	7/8	3/8
5RMZP24	1 1/8	1 1/8	3/8

ELECTRICAL SPECIFICATIONS FOR RMZP24 BY DOOR MANUFACTURER										
CASE MODEL NUMBER	FANS AMPS	(T-10) LIGHT AMPS ONE END*	(T-10) LIGHT AMPS BOTH ENDS	(T-8) LIGHT AMPS	STD. DOOR	MULLION	FRAME	FRAMELESS DOOR	TOTAL FRAME MULLION STD. DOOR	DEFROST HEATER AMPS 220V/1/60Hz.
<b>ANTHONY DOORS</b>										
2RMZP24	0.68	1.5	2.25	1.45	1.48	0.62	1.89	1.56	3.99	5.5
3RMZP24	1.02	2.25	3	1.94	2.22	1.24	2.25	2.34	5.71	8
4RMZP24	1.36	3	3.75	2.42	2.96	1.86	2.65	3.12	7.47	10
5RMZP24	1.7	3.75	4.5	2.91	3.7	2.48	3.1	3.9	9.28	12.5
<b>ARDCO DOORS</b>										
2RMZP24	0.68	1.65	2.4	1.89	1.7	1.12	1.9	1.7	4.72	5.5
3RMZP24	1.02	2.4	3.3	2.34	2.55	1.68	2.4	2.55	6.63	8
4RMZP24	1.36	3.3	4.05	3.06	3.4	2.24	2.7	3.4	8.34	10
5RMZP24	1.7	4.05	4.8	3.51	4.25	2.8	3.1	4.25	10.15	12.5
SUBTRACT 0.19 AMPS PER DOOR FOR PSC FAN MOTORS * STANDARD FOR CASE IN A LINE-UP VOLTAGE: 115 VOLTS 1 PHASE 60 HZ.										
BTU/HR ENERGY REQUIREMENTS: FROZEN FOOD -14°F EVAP. & ICE CREAM -20°F EVAP.										
# OF DOORS	BTU/HR @ -14°F	BTU/HR @ -20°F	BTU/HR RATING BASED ON 1500 MA. T-10 LIGHTING AND PARALLEL RACK SYSTEM. MULTIPLY BY 1.04 FOR CONVENTIONAL SYSTEM							
2	3375	3620	CASE DESIGNED TO OPERATE IN AN AMBIENT OF 75°F OR LOWER AND RELATIVE HUMIDITY OF 55% OR LOWER. DEDUCT 57 BTU/HR FOR PSC FAN MOTORS							
3	4455	4775								
4	5530	5930								
5	6625	7100								

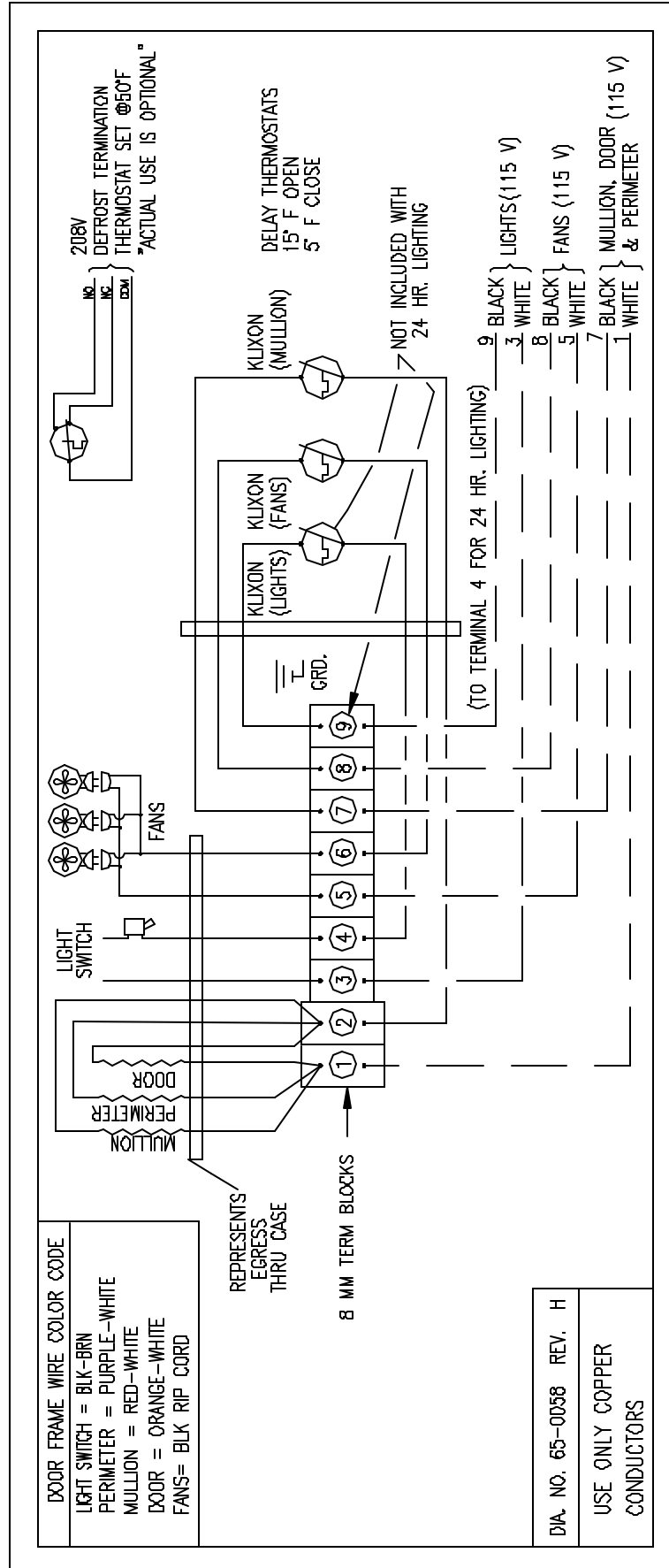
Zero Zone Inc. • 110 N. Oakridge Dr.  
North Prairie, WI 53153-9792  
1-800-247-4496 • FAX: 1-262-392-6450  
www.zero-zone.com

All specifications are subject to change without notice.



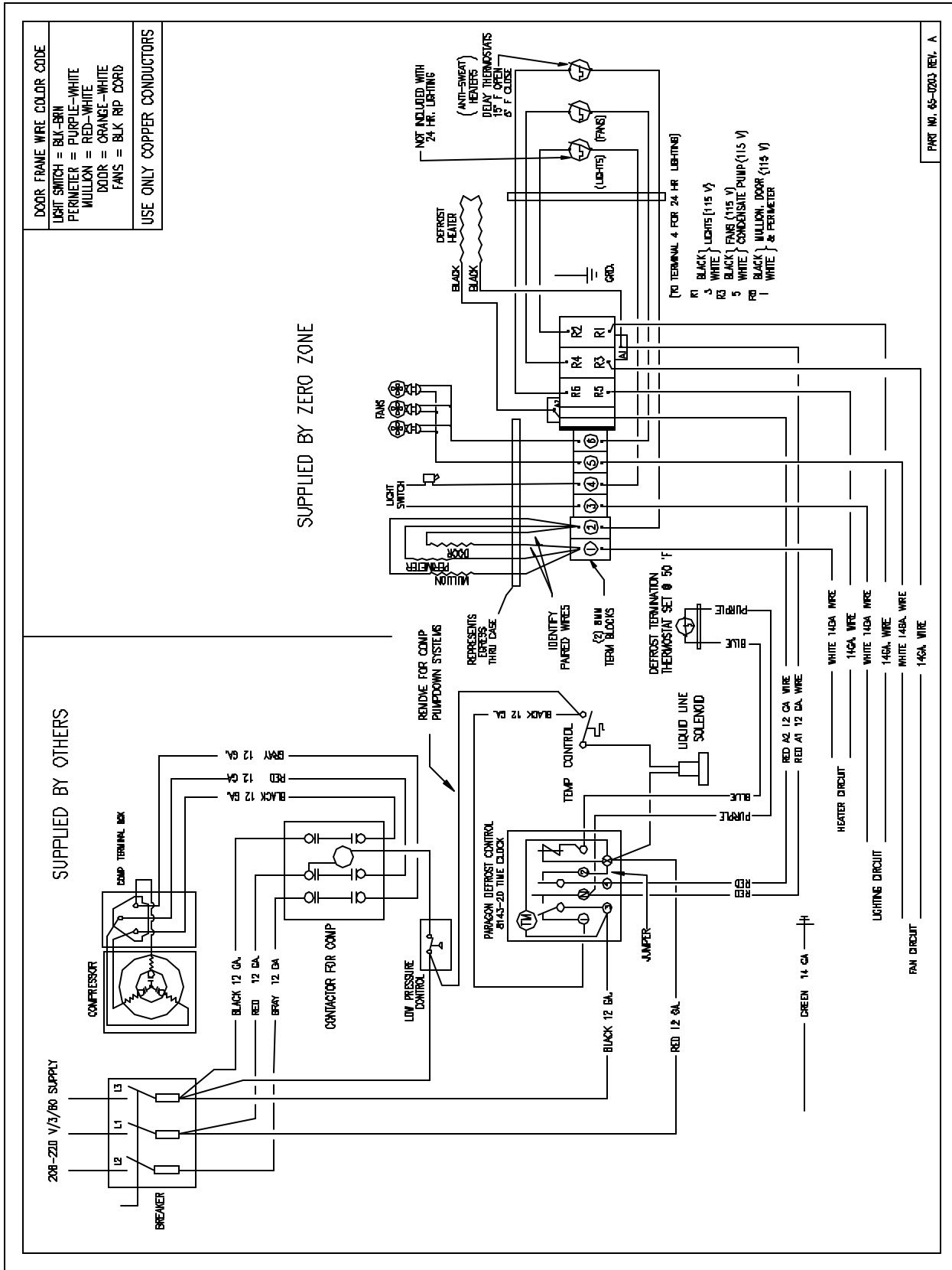
RMZ

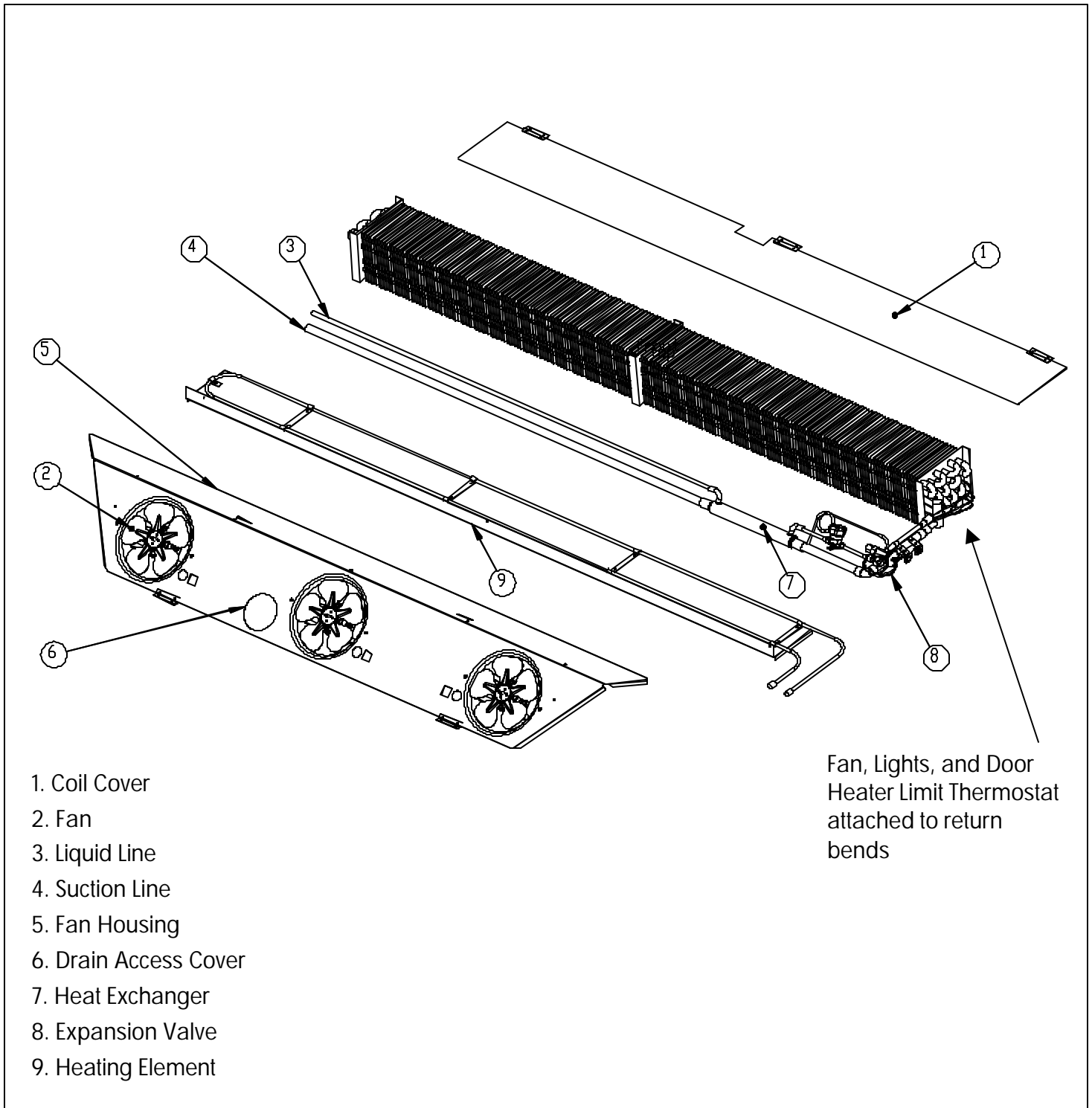
Figure



Figure

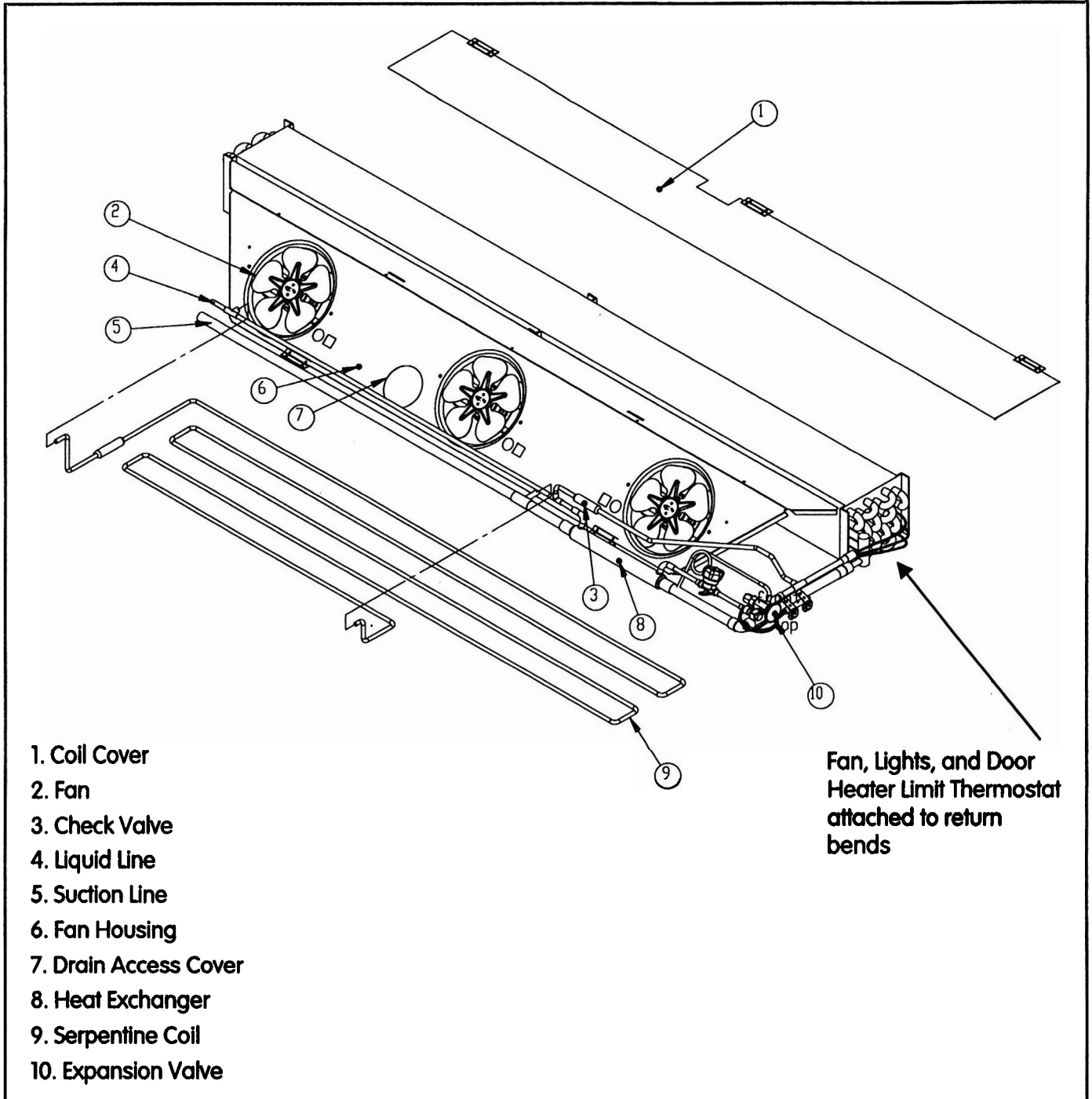
CM





RMZC30, RMZP30 Electric Defrost

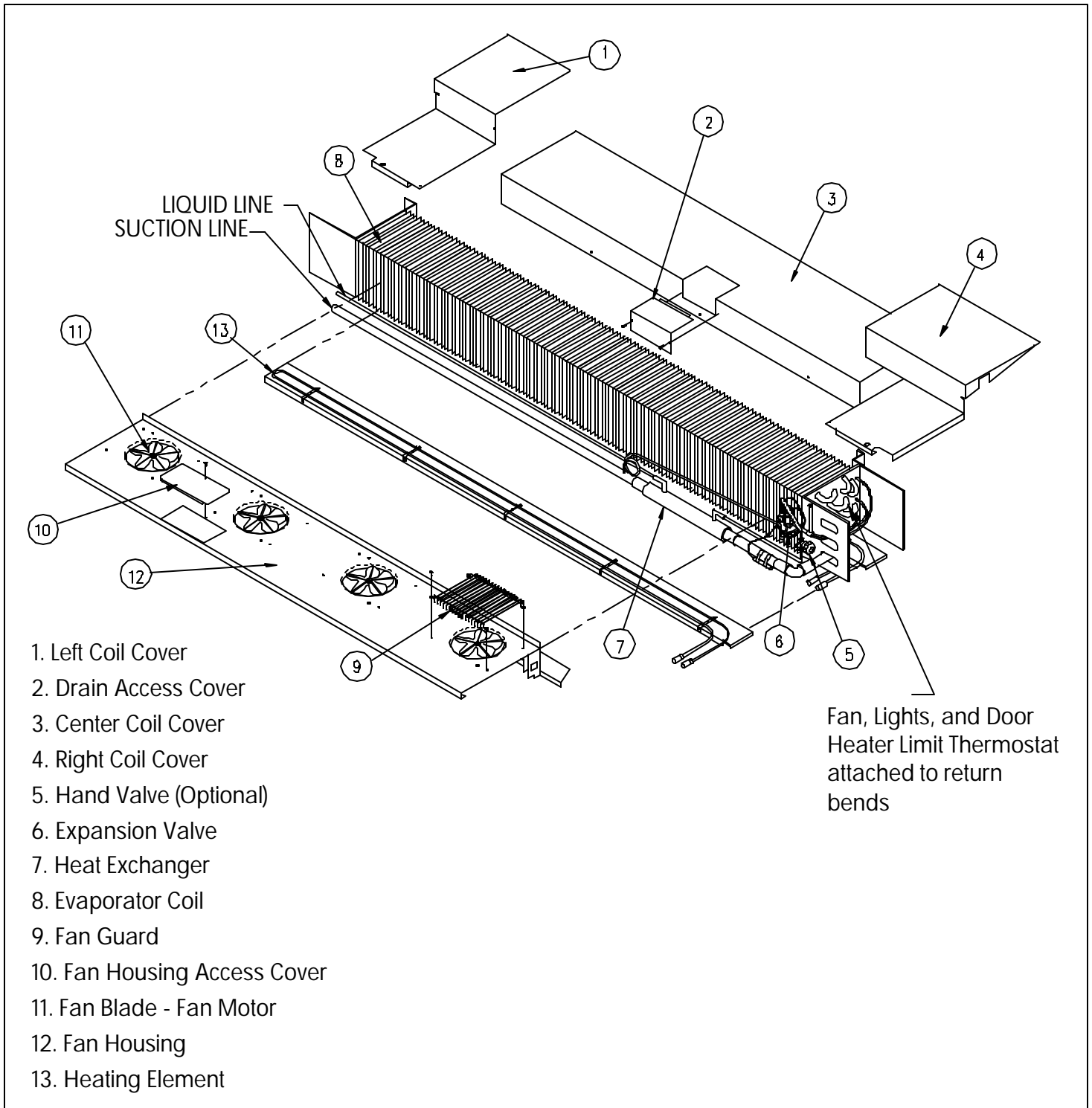
Figure 17



RMZC30, RMZP30, RMZC24 Hot Gas Defrost

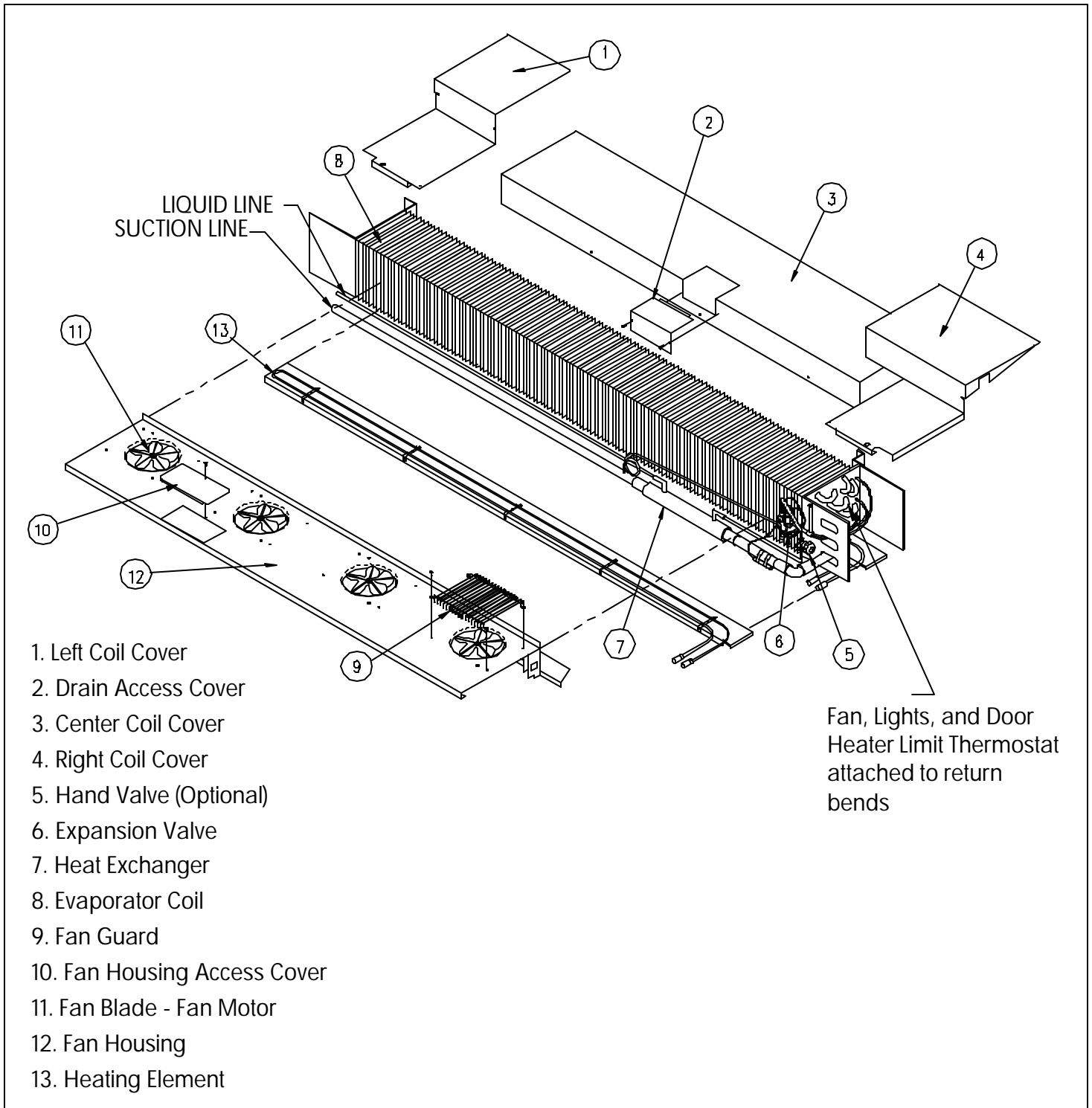
Figure 18





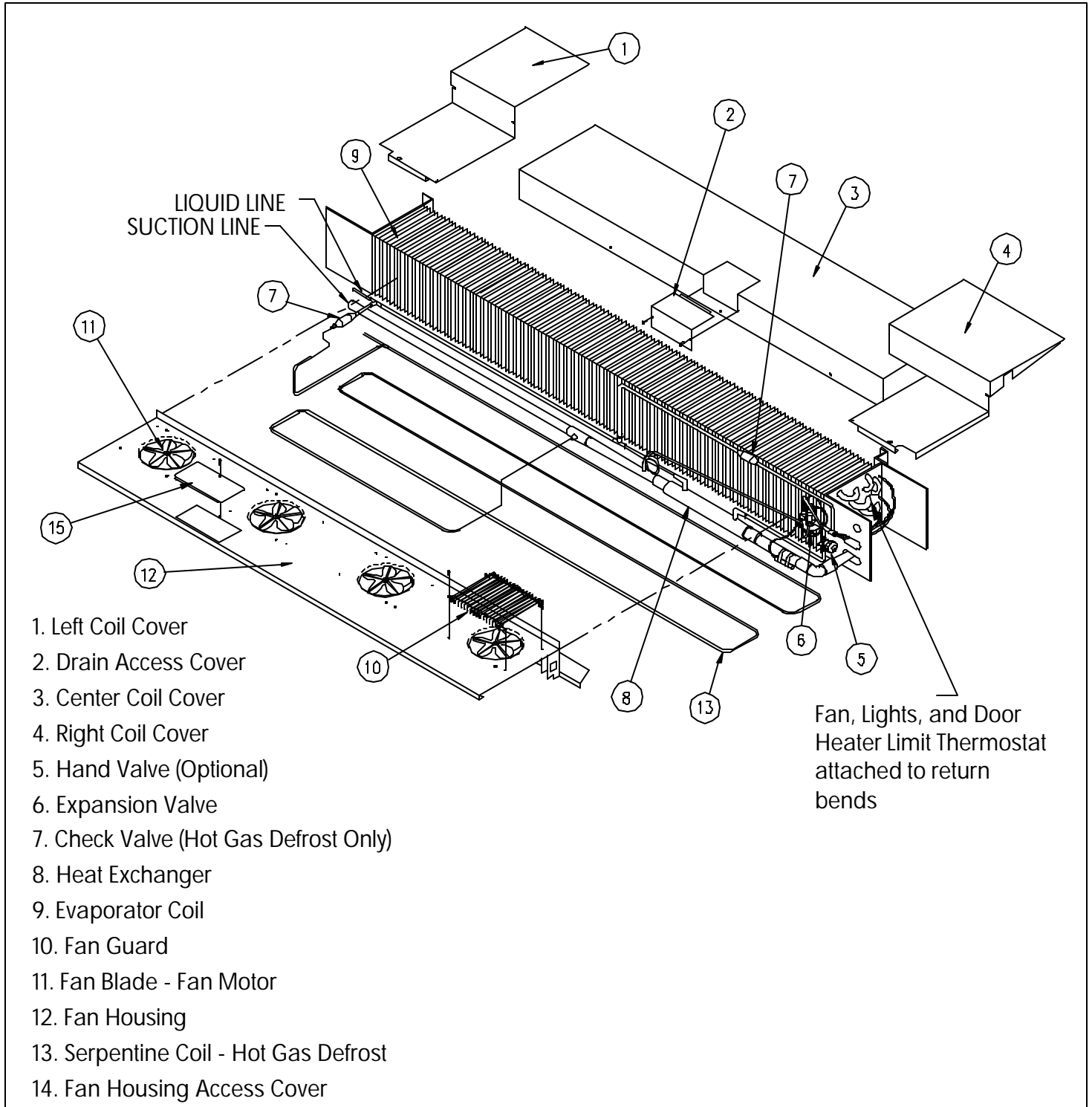
RMZP24 Electric Defrost

Figure 19



RMZP24 Electric Defrost

Figure 19



RMZP24 Hot Gas Defrost

Figure 20



1. **Limited Warranty.** ZERO ZONE, INC. ("Seller") hereby warrants that any products manufactured by it and sold under this Warranty shall be free for a period of one year from the date of shipment, from defects in material and workmanship which, under normal use and service would render such products unusable or unserviceable. The obligation of Seller under this Warranty shall be limited to the repair or replacement of any parts that the Seller determines are defective. This Limited Warranty does not cover labor, freight, transportation or other charges incidental to replacement or repair. Parts returned to Seller must be returned freight prepaid and replacements will be returned to the Buyer freight collect.
2. **Motor Compressor Extended Warranty.** Seller hereby warrants with respect to any motor compressor sold under this Warranty, exclusive of any and all parts of the condensing unit assembly thereof, that such motor compressor shall be free from defects in material and workmanship for a period of four (4) years from the date of the expiration of the one year Warranty provided by the manufacturer of such motor compressor, **if the Buyer purchases said Warranty at the time of equipment purchase.** In the event the motor compressor is not free from defects in material and/or workmanship during such four year period, Buyer must purchase a replacement for the defective motor compressor and obtain whatever salvage credit may be available from the manufacturer thereof. Upon receipt by Seller or written notice from Buyer of compressor, Seller will issue a purchase or a refund, at Seller's option, for an amount of the salvage credit. All labor and shipping charges incurred in connection with such replacement shall be the sole obligation of the Buyer.
3. **Product Not Manufactured by Seller.** The written Warranty, if any, provided by the manufacturer of any part of the refrigeration unit sold by Seller to Buyer, but not manufactured by Seller, is hereby assigned to Buyer. However, Seller makes no representation or Warranty regarding the existence, validity or enforceability of any such written Warranty.
4. **LIMITATION AND EXCLUSION OF WARRANTIES.** THE WARRANTIES SET FORTH HEREIN ARE EXCLUSIVE AND IN LIEU OF ALL OTHER WARRANTIES AND REMEDIES WHATSOEVER, INCLUDING BUT NOT LIMITED TO, IMPLIED WARRANTIES OF MERCHANTABILITY AND/OR FITNESS FOR A PARTICULAR PURPOSE.
5. **Consequential Damages.** Notwithstanding anything to the contrary set forth in this Warranty Certificate, Seller shall not be liable for any incidental or consequential damages arising out of, or directly or indirectly caused by a defective part sold by Seller, including but not limited to, costs arising from the replacement of the part, loss of gas or product, or any damage to person or property, whether as a result of Seller's negligence, breach of contract, breach of Warranty or otherwise.

Model No. \_\_\_\_\_ Serial No. \_\_\_\_\_