

INSTALLATION and OPERATING INSTRUCTIONS for

*D*isplay
Coolers

GIAB Series



Shop Around



Rear Load



DCR-63 Series





TABLE OF CONTENTS

Subject	
GENERAL INFORMATION	1
INTRODUCTION	1
INSPECTION	1
LOCATION	1
INSTALLATION	1
LEVELING	1
JOINING COOLERS	2-3
DRAIN LINE	3
CART BUMPER	3
REFRIGERATION	3
GENERAL	3
REFRIGERANT PIPING	3
TEMPERATURE CONTROL	4
TEMPERATURE CONTROL ADJUSTMENT	4
LEAK CHECK-EVACUATION-CHARGING	4
ELECTRICAL	4-5
DEFROSTING	5
USER INFORMATION	5
CLEANING	6
SHELF LOCATION	5
LANE DIVIDERS	6
SHELF GUIDES	6
PRE CUT SALAD RACK	6
FLORAL SHELVES	6
LOADING THE COOLER	6
LIGHT SWITCH	6
SERVICE	6
CART BUMPER	6
EVAPORATOR	7
EXPANSION VALVE	7
EVAPORATOR FANS	7
LIGHTS	7
BALLASTS	7
ALTERNATE LIGHTING - TB	7
CONDENSATE EVAPORATION SYSTEM	8
FULL PAGE TABLES	
TABLE 1 RI-DCR-GIAB/GIAB-RI LINE SIZE R22	9
TABLE 2 RI-DCR-GIAB-SA LINE SIZE R22	10
TABLE 3 RI DCR 63 LINE SIZE R22	11
FULL PAGE FIGURES	
FIGURE 5 DCR-GIAB SPECIFICATION SHEET	12
FIGURE 6 DCR-GIAB-RL SPECIFICATION SHEET	13
FIGURE 7 DCR-GIAB-SA SPECIFICATION SHEET	14
FIGURE 8 DCR-63 SPECIFICATION SHEET	15
FIGURE 11 DCR-GIAB/DCR-63 WIRING DIAGRAM	16
FIGURE 12 GIAB, GIAB-RL ELECTRICAL VALUES	17
FIGURE 13 GIAB-SA, DCR-63 ELECTRICAL VALUES	18
FIGURE 18 DCR-GIAB/DCR-63 LIGHT/BALLAST WIRING DIAGRAM	19



GENERAL INFORMATION

Introduction

The information contained in this manual pertains to the following display coolers: RI-DCR-GIAB and RI-DCR-63. These are used for merchandising refrigerated packaged food. These display coolers are designed to operate in an air-conditioned store where the temperature is maintained at 75°F or lower and the relative humidity is at 55% or lower.

RI DCR GIAB RL (Rear Load)

This case design allows product to be loaded through solid sliding doors at the rear of the case. The case is designed to have the rear built into the wall of a walk-in cooler. The doors do not have lamps but are heated to prevent condensation. Detailed instructions can be found in the door manufacturer's instruction sheet.

RI-DCR-GIAB-SA (Shop Around)

This case design allows product to be shopped from either side. The evaporator fans face the front of the case. The main wiring compartment is located behind the kick plate in the front of the case. If ballasts are supplied by Zero Zone and not the door manufacturer, they will be located behind the kick plate.

RI-DCR-GIA-F (Floral)

This case design includes a black interior. Special shelves and floral buckets are available for merchandising flowers.

Inspection

These display coolers were carefully inspected and properly packed to ensure delivery in the best possible condition. The equipment should be checked for damage immediately upon delivery. **ALL CLAIMS FOR DAMAGES MUST BE FILED WITH THE TRANSPORTATION COMPANY - NOT WITH ZERO ZONE.** The carrier will supply necessary report and claim forms.

Location

Do not locate this equipment where it will be exposed to the direct rays of the sun or near a source of radiant heat or air flow.

Be certain that the floor under the installation is of sufficient strength to prevent sagging. Out of level conditions will result in reduced performance.

Wall cases, and back to back cases, should be positioned to allow a 1 - 4 inch space behind the back of a unit. This space will allow air to circulate behind the unit.

INSTALLATION

Leveling (See Figure 1)

Refrigeration equipment must be installed level to allow efficient operation of the refrigeration coils and complete drainage of defrost water. Since a level area is seldom available, the following steps are recommended to insure a level installation.

1. Measure off and mark on the floor the exact dimensions of the case line-up. (Check blueprints).
2. Snap a chalk line at the locations for the front and back positions of the base rails.
3. Mark locations of all joints (front and back).
4. Using a transit, find the highest point along both base rail position lines. Using the high point as a reference, mark the difference directly on the floor at each joint (front and back).
5. If a transit is not available, a water level can be used to mark reference elevation points. Water levels can be purchased from a contractor supply house for a minimal cost.
6. A string level can also be used to mark elevation points. The string level should only be used on short line-ups to avoid string sag.
7. Place the required number of shims (supplied) at each joint (front and back) to equal the highest point. Tape all shims in place.
8. Place additional support shims at the center of four and five door case base rails (front and back).
9. Use a carpenter's level to check installation as you go. The case should be level from front to back and side to side. Install the case at the highest point first - if part of a line-up.

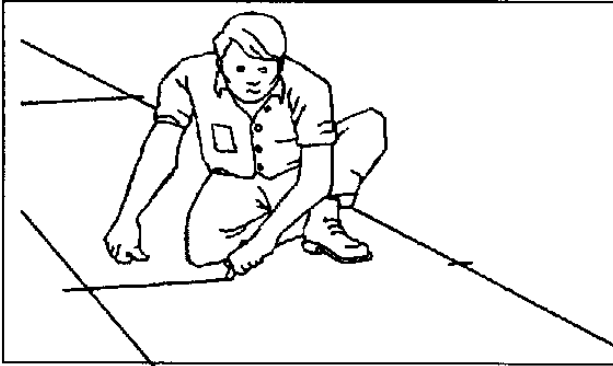

Measure and mark exact case outline

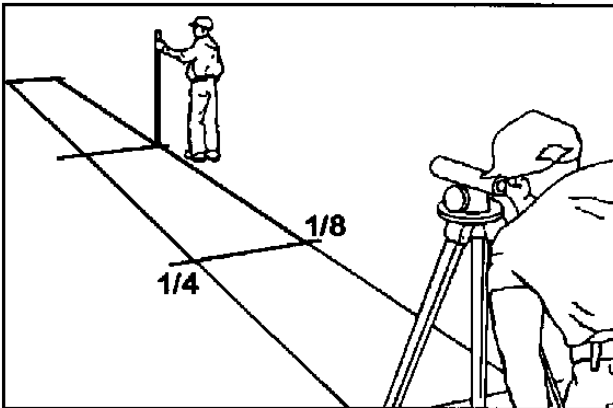

Mark floor level differences

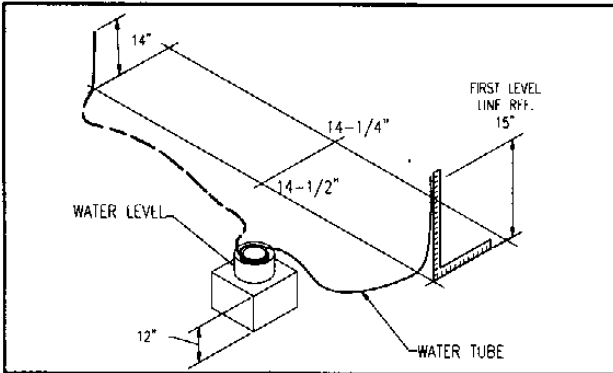

Water level elevation points

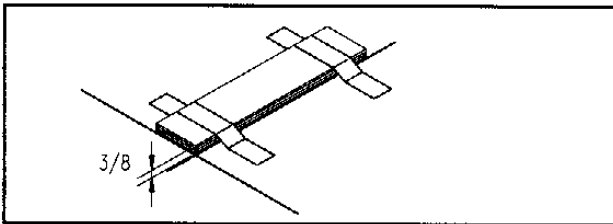

Shim joints to equal highest points
Figure 1: Leveling cases prior to joining

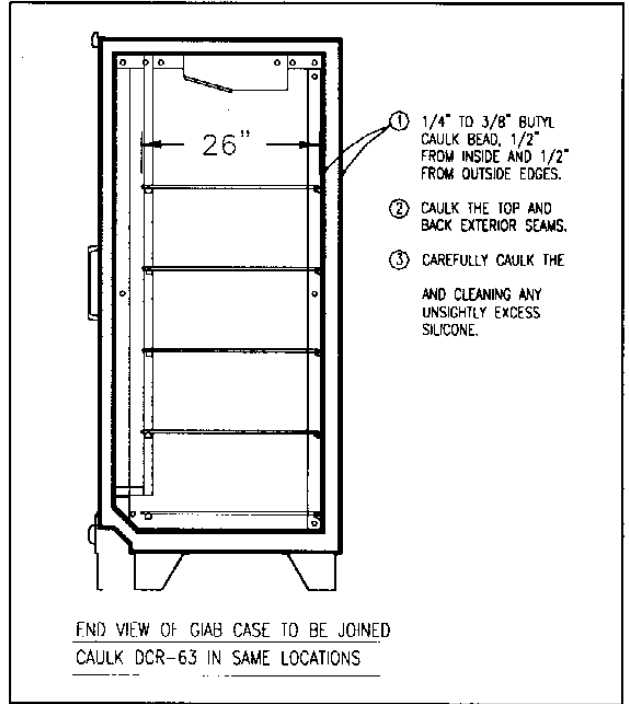

Figure 2: Caulking cases to be joined

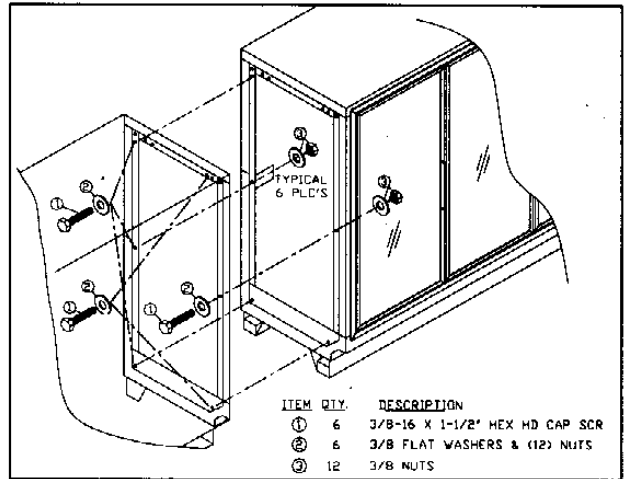

Figure 3 Joining Reach-In Freezers

Joining Coolers

These Reach-Ins have been engineered for continuous display. This means that any number of Reach-In coolers can be joined together to create a display of any desired length. Reach-In coolers are built on permanent steel skids to promote easy installation. The case can be moved on pipe rollers or with a

Johnson Bar. The ends of the case are protected with a removable steel plate.

To install Reach-Ins, perform the following steps.

1. Set the first Reach-In at the desired position and level it. Run a 3/8 inch diameter bead of Butyl caulk 1/2 inch in from both the inner and outer surfaces of the case end. (See Figure 2)
2. Push the second Reach-In against the end of the first. Level the second Reach-In.
3. Start all joining bolts, but do not tighten them. Begin tightening the bolts at the top rear, working down the back of the case and up the front making sure that the front seams are flush. (See Figure 3).

Drain Line

Condensate drains from the evaporator through a plastic hose mounted at the rear of the case. The tubing should be free of kinks and dirt so water drains freely. The case drain is located at the center of the cooler in the floor pan. The 1 inch PVC drain outlet is located at the center front of the cooler behind the kick plate.

Install a tee to the outlet pipe and a PVC drain trap to the tee. Plug the open end of the tee using the clean-out plug supplied with the drain trap kit. The drain line must be pitched away from the case a minimum of 1/4 inch per foot. The tee, drain trap, and plug are supplied standard with the case.

Cart Bumper

The cart bumper should be installed at the bottom front of the case. (See Figure 4) The assembly is adjustable to compensate for uneven floors.

Center and hook the bumper assembly on the hangers provided.

In continuous line-ups, place a kick plate joint strip at each joint. On case ends, line-up an end kick plate with the front mounting holes. Fasten the rear of the end kick plate to the case using tech screws.

Slide the front kick plate behind the bumper assembly and in front of the end kick plate or kick plate joint strip. Install three screws (two screws on two door only) to hold the kick plate and bumper in place.

A bumper joint strip can be installed over the bumper at the joints. This is standard on Euro Style Trim and optional on Classic Style Trim.

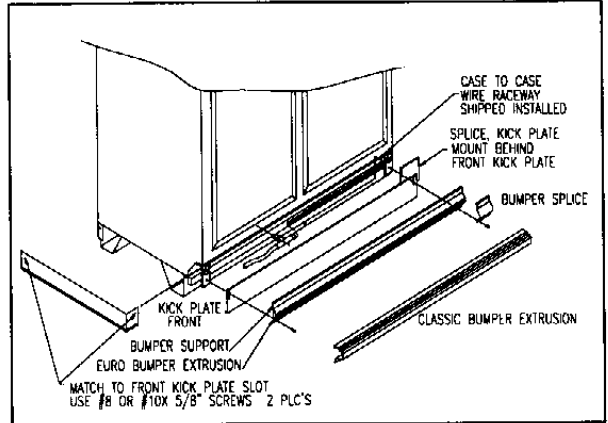

Figure 4: Case Bumper Assembly

REFRIGERATION

General

Unless otherwise specified, the liquid and suction connections are made on top of the case. (See Figures 5, 6, 7 and 8.) Alternate locations are out the back of the case. After connections have been made, the refrigeration access hole in the cooler must be sealed completely with aerosol-dispensed Urethane insulation or equivalent.

Refrigerant Piping

Correct refrigeration line sizing and installation is essential for proper system operation. The following tables (Tables 1 to 3) list R-22 line sizes for different combinations of coolers. A P-trap must be installed at the bottom of all vertical suction risers.

The compressor should be installed as close as possible to the coolers to reduce pressure drop. If the compressor is located above the cooler, use one size smaller tube for the suction tube riser only and install a shallow trap at the bottom of the riser. Use a flexible connection (vibration eliminator) between the suction line and compressor.

The suction and liquid lines may be taped together to form an external heat exchanger. Insulate the tubing for at least 20 feet from the cooler outlet. A liquid line drier should be installed. Install a moisture indicating sight glass at the outlet end of the drier.

Temperature Control

A low pressure or temperature control can be used to control cooler temperature. The control should be selected with adequate contact capacity for the

TIME CLOCK DEFROST PRODUCT 41°F TO 37°F		
	Pressure (psig)	RETURN AIR Temp.
	R-22	
Cut In	64	37°F
Cut Out	40	33°F
OFF CYCLE DEFROST PRODUCT 41°F TO 37°F		
	Pressure (psig)	RETURN AIR Temp.
	R-22	
Cut In	68	40°F
Cut Out	42	34°F

Figure 9

switching load. In rack systems, an evaporator pressure regulating valve may be used to control the evaporating temperature.

The settings (See Figure 9) are approximate due to variations in gauge accuracy, differences in compressor efficiency, and line pressure drop. These should be adjusted as store or stocking conditions change.

Temperature Control Adjustment

When factory installed, the temperature control is located on top of the cooler. The sensing bulb is located under the coil cover in front of the coil. It may be wired in place of the low pressure (L.P.) control. The wiring diagram shows use of the thermostat in a pump down system. See applicable wiring diagrams. (Figure 10 shows a typical temperature control.)

Leak Check-Evacuation-Charging

After all of the refrigeration piping and system components have been assembled, the entire system must be pressurized and checked for leaks. Use nitrogen and refrigerant vapor to check for leaks. A Halide leak detector or an electronic leak detector is recom-

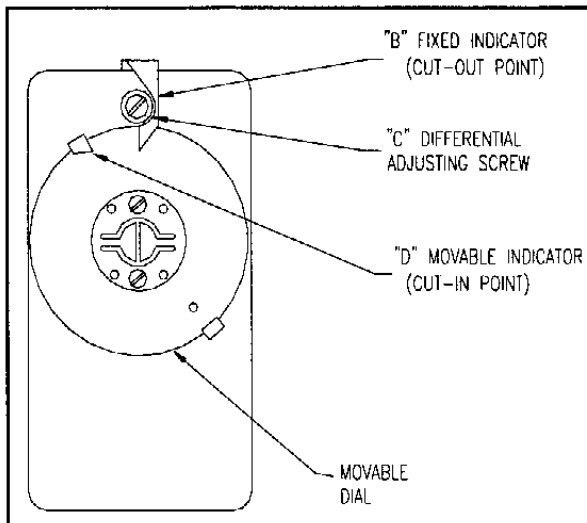

Figure 10: Typical Temperature Control

mended.

If the system is sealed, evacuate with a high vacuum pump. Triple evacuation to a minimum of 500 microns and nitrogen sweep is recommended. After the system has been thoroughly evacuated of all moisture and non-condensable gas, charge the system with the proper refrigerant, using "hi-side/low-side" charging techniques.

ELECTRICAL

Figure 11 shows the typical wiring diagram for a cooler. Each case is provided with a wiring diagram located in the electrical box that shows the exact wiring of the case.

External wiring should be sized according to the amperage rating stamped on the serial plate. The serial plate is located on the ceiling inside the left hand door. Typical electrical values are shown in Figure 12 & 13. All internal wiring has been done at the factory, and has been terminated in the electrical compartment located behind the kick rail at the right end of the case. The temperature control mounted on top of the case is not wired. A terminal block has been used to simplify field connections.

The terminal block is an insulation displacement type block. It features an internal self-stripping wire mechanism. These cutting blades eliminate the need for manual wire stripping on the case side of the block. A wire can only be inserted in the block two

insertion tools can be purchased from the factory, or a small instrumentation screw driver can be used. The customer's side of the block utilizes a screw clamp connection to accommodate multiple wire insertions. See Figure 14 for standard wire size range per terminal block.

The fan circuit is energized at all times. The light and anti-condensate circuit may be cycled off during defrost. The time clock is in operation at all times.

TERMINAL BLOCK WIRE SIZE SPECIFICATIONS		
TERMINAL BLOCK DESCRIPTION	CURRENT RATING (AMP)	CUSTOMER WIRE SIZE
SELF-STRIPPING 6MM (1/4")	18A	22-12 AWG.
SELF-STRIPPING 8MM (5/16")	25A	22-8 AWG.
COMPRESSION CLAMP 8MM (5/16")	50A	22-8 AWG.

Figure 14: Terminal Block Chart

Note: All wiring must comply with the National Electrical Code and all local codes.

DEFROSTING

Periodic defrosting to keep the coil free of frost is accomplished automatically by a time clock or with compressor off cycle defrost. The most reliable defrost system uses a time clock that turns off the refrigeration cycle once per day for 60 minutes. A time clock can be purchased from Zero Zone or from a local refrigeration supply house.

When only OFF cycle defrost is used, the compressor must be sized large enough to allow for periodic off cycles. When the compressor shuts off, the evaporator fans continue to run. This allows the coil to defrost. The cut-in set point for the compressor should be not lower than 40°F when OFF cycle defrost is used.

USER INFORMATION

Cleaning

The cooler should be thoroughly cleaned before start-up and routinely thereafter to maintain a clean appearance. Use a mild detergent and warm water (never an abrasive cleaner) to wipe out the inside of the cooler. Wash down all glass doors with glass cleaner. The cooler will remain bright and sparkling with just a few minutes of cleaning each week. The case drain should be regularly cleared of debris and price tags

Note: Do not use high pressure water or steam to clean the interior.

Shelf Location

The shelves are adjustable in 1/2 inch increments. They may be located in any position for best display advantage. Due to the air discharge arrangement, it is suggested that the uppermost shelf be placed 11 inches down from the ceiling. Place the remaining shelves approximately 10 1/2 inches apart.

Be sure shelf clips or brackets are completely seated before installing the shelf.

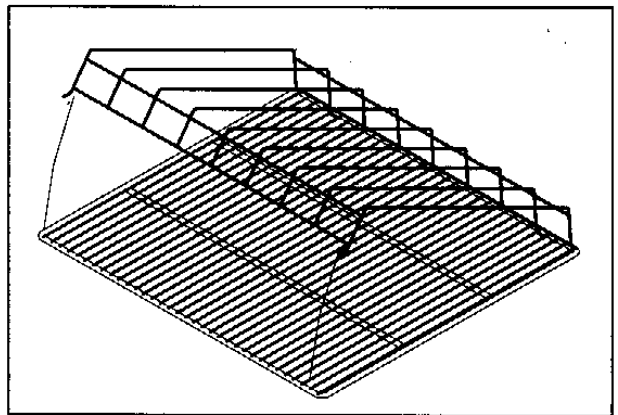

Figure 15: Lane Dividers

Shelf Accessories

Lane Dividers

Lane dividers with 2-29/32 inch, 3-7/32 inch, 3-13/16 inch, or 4-47/64 inch wide lanes are available for use on the shelves. The rear of the lane divider has the

shelf hooks inset from the end. The lane divider is installed by hooking the rear hooks under the large shelf wire (See Figure 15). Flex the lane divider and hook the wire under the large front shelf wire.

Shelf Glides

Shelf glides are available for use with lane dividers. This helps the product gravity feed to the front of the case.

Pre Cut Salad Rack

The rear of the rack has two feet that slip under the shelf wires. The rear of the rack also has a raised wire stop. The stop is used to provide an air gap between the product and rear wall.

The rack is installed as follows:

1. Set the rack on top of the shelf.
2. Rotate the rack 45 degrees to the side.
3. Slide both rear feet under the shelf wires.
4. Rotate the salad rack back to the original position while keeping the rear feet under the wires.

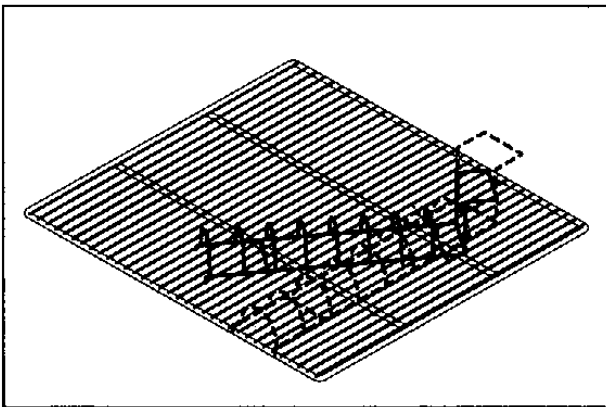

Figure 16: Salad Rack

5. Gently squeeze the front of the rack and slide the two feet between the shelf wires (See Figure 16).

Floral Shelves

Glass cantilever floral shelves are available. The shelves rest on special extra wide shelf brackets.

Cantilever floral bucket shelves are also available. The bucket shelf bracket is adjustable to allow for shelf tilting. Before attempting to adjust the shelf bracket, follow these steps:

1. Remove the shelf.
2. Remove the set screw from the side of the bracket.
3. Rotate the bracket to the new position.
4. Install the set screw.

Cantilever shelf standards are factory installed and must be ordered with a new case.

Loading the Cooler

The cooler may be loaded with merchandise after it has been operated for at least 24 hours with correct case temperature and proper control operation. While loading the shelves, leave at least 1 1/2 inch above it so the customer can remove the merchandise. This also allows an air curtain on the top of the product. Leave a 1 1/2 inch air gap at the rear of the case. This allows cool air to travel down the back of the product and return to the evaporator at the front of the case.

For proper display, the products should be placed on edge and slanted to the back so the customer sees the face of the packages. Rotate inventory on a regular basis.

Light Switch

The light switch is located inside the cooler in the upper right corner of the door frame. Always turn the lights off when replacing lamps.

SERVICE

Cart Bumper

The cart bumper must be removed to gain access to the drain connection and electrical connection. Disassemble the bumper and black kick plate by removing the 2 or 3 metal screws located in the kick plate. The bumper assembly can be lifted up and removed from the case. The kick plate can be removed, exposing the electrical connection and drain outlet. (Figure 4 shows the bumper assembly)

Evaporator

The evaporator coil, located at the ceiling of the cooler, is factory assembled with an expansion valve. To inspect the coil, the coil cover can be removed as follows:

Loosen two screws on the underside of the coil cover until the forward edge drops down exposing the evaporator coil and fan assemblies.

While supporting the cover, unplug the fan electrical connection from main coil housing.

Expansion Valve

A thermostatic expansion valve with a "C" charge, adjustable super-heat and thermal bulb is mounted to the evaporator coil. Under certain conditions, it may be necessary to adjust the super-heat setting for maximum coil effectiveness. Typical super heat settings are between 10°F and 15°F. To adjust the expansion valve, remove the coil cover. Remove the cap from the bottom of the valve. When looking at the valve stem end, turn the valve stem counter-clockwise to decrease super heat. Turn the valve stem clockwise to increase super heat. Measure the suction line temperature at the expansion valve sensing bulb and compare it to the suction temperature corresponding to the saturated pressure. Make sure that line pressure drop is taken into account.

Turn the valve stem only 1/4 turn at a time and allow sufficient time (20 to 30 minutes) for the valve to settle before making any further adjustments. Replace the valve stem cap after the valve super-heat has been adjusted. BE CERTAIN THE VALVE STEM CAP IS WIPED DRY FIRST.

! CAUTION !
DISCONNECT POWER TO THE CASE BEFORE
SERVICING ELECTRICAL COMPONENTS

Evaporator Fans

Air is circulated throughout the cooler with shaft down, 115 volt medium temperature fan motors. These motors must be operating at all times. The fans are mounted on the evaporator coil cover. To service the fans, they are accessed by removal of the coil cover as described under SERVICE/EVAPORATOR.

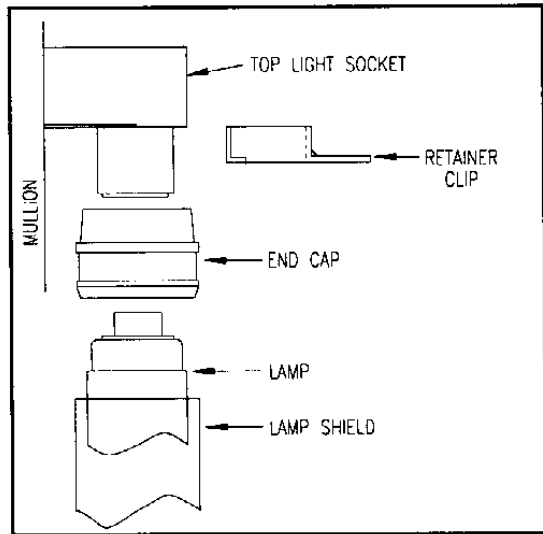

Figure 17: Socket detail

Lights

High output 800 milliamp lamps are standard. To ensure maximum component life, always replace with 800 milliamp lamps. Use retainer clips and lamp shields.

To change a lamp, turn off the light switch and remove the retainer clip located between the top socket and end cap. Carefully push the lamp up into the spring-loaded lamp socket to allow the lamp to be removed from the bottom socket. (See Figure 17.) Remove the end caps and shield. All lamps must use end caps and shields.

Ballast

Zero Zone cooler ballasts are located either behind the kick plate or in the door mullions. Figure 18 shows which ballast is connected to which lamp when the ballasts are located behind the kick plate.

Alternate Lighting -T8

T-8 lighting is optional. Many door manufacturers provide premium lighting systems. These systems use a lens to direct light output evenly across the shelves. The lamp used is a Osram FO40W/41K (5ft). The lens must be removed to access the lamp. The lamp may be removed by turning it 90 degrees and sliding the lamp pins out of the lamp socket slot. The jacket must be installed over the lamp. Detailed information is contained in the door instruction booklet.

Condensate Evaporation System

Zero Zone remote cases can be equipped with an automatic condensate evaporation system. The system uses a pump and drain pan located behind the kick plate and a condensate evaporator pan mounted on the top of the case.

Condensate and any liquid spilled in the case drain out into the drain pan. The pump is equipped with a float that turns the pump on when there is a sufficient liquid level. Liquid is pumped through a plastic hose through a check valve and into the condensate evaporating pan. The evaporating pan is equipped with a heater and a float switch to turn on when the heater is submerged in liquid. When the heater is energized the pan will be extremely hot and should not be touched.

The pump and condensate pan should be cleaned regularly. Any spilled product should be cleaned to prevent odors.

TABLE 1

ZERO ZONE

**REMOTE REACH-IN COOLER W/ 30" X 63" DOORS
MODEL RI-DCR-GIAB/GIAB-RL 37 °F TO 41 °F PRODUCT
REFRIGERANT R-22 @ 20 °F EVAPORATOR**

NO. OF DOORS	FREEZER COMBINATIONS	TOTAL LENGTH W/ENDS	BTU/HR	RECOMMENDED LIQUID LINE SIZES EQUIVALENT LENGTH, FEET			RECOMMENDED SUCTION LINE SIZES EQUIVALENT LENGTH, FEET		
				50	100	150	50	100	150
2	(1) 2-DR	5'-9"	2735	3/8	3/8	3/8	1/2	1/2	1/2
3	(1) 3-DR	8'-3 1/2"	3705	3/8	3/8	3/8	1/2	1/2	1/2
4	(1) 4-DR	10'-11"	4650	3/8	3/8	3/8	1/2	1/2	5/8
5	(1) 5-DR	13'-6 1/2"	5625	3/8	3/8	3/8	1/2	5/8	5/8
6	(2) 3-DR	16'-2"	6750	3/8	3/8	3/8	1/2	5/8	5/8
7	(1) 3-DR & (1) 4-DR	18'-9 1/2"	7875	3/8	3/8	3/8	5/8	5/8	7/8
8	(2) 4-DR	21'-5"	9000	3/8	3/8	3/8	5/8	5/8	7/8
9	(1) 4-DR & (1) 5-DR	24'-1/2"	10125	3/8	3/8	3/8	5/8	7/8	7/8
10	(2) 5-DR	26'-8"	11250	3/8	3/8	3/8	5/8	7/8	7/8
11	(1) 3-DR & (2) 4-DR	29'-3 1/2"	12375	3/8	3/8	3/8	5/8	7/8	7/8
12	(3) 4-DR	31'-11"	13500	3/8	3/8	3/8	7/8	7/8	7/8
13	(2) 4-DR & (1) 5-DR	34'-6 1/2"	14625	3/8	3/8	3/8	7/8	7/8	7/8
14	(1) 4-DR & (2) 5-DR	37'-2"	15750	3/8	3/8	3/8	7/8	7/8	7/8
15	(3) 5-DR	39'-9 1/2"	16875	3/8	3/8	1/2	7/8	7/8	7/8
16	(4) 4-DR	42'-5"	18000	3/8	3/8	1/2	7/8	7/8	7/8
17	(3) 4-DR & (1) 5-DR	45'-1/2"	19125	3/8	3/8	1/2	7/8	7/8	7/8
18	(2) 4-DR & (2) 5-DR	47'-8"	20250	3/8	3/8	1/2	7/8	7/8	1 1/8
19	(1) 4-DR & (3) 5-DR	50'-3 1/2"	21375	3/8	3/8	1/2	7/8	7/8	1 1/8
20	(4) 5-DR	52'-11"	22500	3/8	3/8	1/2	7/8	7/8	1 1/8
21	(4) 4-DR & (1) 5-DR	55'-6 1/2"	23625	3/8	3/8	1/2	7/8	7/8	1 1/8
22	(3) 4-DR & (2) 5-DR	58'-2"	24750	3/8	1/2	1/2	7/8	1 1/8	1 1/8
23	(2) 4-DR & (3) 5-DR	60'-9 1/2"	25875	3/8	1/2	1/2	7/8	1 1/8	1 1/8
24	(1) 4-DR & (4) 5-DR	63'-5"	27000	3/8	1/2	1/2	7/8	1 1/8	1 1/8
25	(5) 5-DR	66'-1/2"	28125	3/8	1/2	1/2	7/8	1 1/8	1 1/8
26	(4) 4-DR & (2) 5-DR	68'-8"	29250	3/8	1/2	1/2	7/8	1 1/8	1 1/8
27	(3) 4-DR & (3) 5-DR	71'-3 1/2"	30375	3/8	1/2	1/2	7/8	1 1/8	1 1/8
28	(2) 4-DR & (4) 5-DR	73'-11"	31500	3/8	1/2	1/2	7/8	1 1/8	1 1/8
29	(1) 4-DR & (5) 5-DR	76'-6 1/2"	32625	3/8	1/2	1/2	7/8	1 1/8	1 1/8
30	(6) 5-DR	79'-2"	33750	3/8	1/2	1/2	7/8	1 1/8	1 1/8

BTU/HR RATING BASED ON 800 ma T-12 LIGHTING. CASE DESIGNED TO OPERATE IN AN AMBIENT OF 75 °F OR LOWER AND RELATIVE HUMIDITY OF 55% OR LOWER

TABLE 2

**REMOTE REACH-IN COOLER W/ 30" X 63" DOORS
MODEL RI-DCR-GIAB-SA 37 °F TO 41 °F PRODUCT
REFRIGERANT R-22 @ 20 °F EVAPORATOR**

NO. OF DOORS	FREEZER COMBINATIONS	TOTAL LENGTH W/ENDS	BTU/HR	RECOMMENDED LIQUID LINE SIZES EQUIVALENT LENGTH, FEET			RECOMMENDED SUCTION LINE SIZES EQUIVALENT LENGTH, FEET		
				50	100	150	50	100	150
2	(1) 2-DR	5'-9"	4785	3/8	3/8	3/8	1/2	1/2	5/8
3	(1) 3-DR	8'-3 1/2"	6485	3/8	3/8	3/8	1/2	5/8	5/8
4	(1) 4-DR	10'-11"	8140	3/8	3/8	3/8	5/8	5/8	7/8
5	(1) 5-DR	13'-6 1/2"	9845	3/8	3/8	3/8	5/8	7/8	7/8
6	(2) 3-DR	16'-2"	11814	3/8	3/8	3/8	5/8	7/8	7/8
7	(1) 3-DR & (1) 4-DR	18'-9 1/2"	13783	3/8	3/8	3/8	5/8	7/8	7/8
8	(2) 4-DR	21'-5"	15752	3/8	3/8	3/8	7/8	7/8	7/8
9	(1) 4-DR & (1) 5-DR	24'-1/2"	17721	3/8	3/8	1/2	7/8	7/8	7/8
10	(2) 5-DR	26'-8"	19690	3/8	3/8	1/2	7/8	7/8	1 1/8
11	(1) 3-DR & (2) 4-DR	29'-3 1/2"	21659	3/8	3/8	1/2	7/8	7/8	1 1/8
12	(3) 4-DR	31'-11"	23628	3/8	1/2	1/2	7/8	7/8	1 1/8
13	(2) 4-DR & (1) 5-DR	34'-6 1/2"	25597	3/8	1/2	1/2	7/8	1 1/8	1 1/8
14	(1) 4-DR & (2) 5-DR	37'-2"	27566	3/8	1/2	1/2	7/8	1 1/8	1 1/8
15	(3) 5-DR	39'-9 1/2"	29535	3/8	1/2	1/2	7/8	1 1/8	1 1/8
16	(4) 4-DR	42'-5"	31504	3/8	1/2	1/2	7/8	1 1/8	1 1/8
17	(3) 4-DR & (1) 5-DR	45'-1/2"	33473	3/8	1/2	1/2	7/8	1 1/8	1 1/8
18	(2) 4-DR & (2) 5-DR	47'-8"	35442	3/8	1/2	5/8	1 1/8	1 1/8	1 1/8
19	(1) 4-DR & (3) 5-DR	50'-3 1/2"	37411	1/2	1/2	5/8	1 1/8	1 1/8	1 1/8
20	(4) 5-DR	52'-11"	39380	1/2	1/2	5/8	1 1/8	1 1/8	1 3/8
21	(4) 4-DR & (1) 5-DR	55'-6 1/2"	41349	1/2	1/2	5/8	1 1/8	1 1/8	1 3/8
22	(3) 4-DR & (2) 5-DR	58'-2"	43318	1/2	5/8	5/8	1 1/8	1 1/8	1 3/8
23	(2) 4-DR & (3) 5-DR	60'-9 1/2"	45287	1/2	5/8	5/8	1 1/8	1 1/8	1 3/8
24	(1) 4-DR & (4) 5-DR	63'-5"	47256	1/2	5/8	5/8	1 1/8	1 1/8	1 3/8
25	(5) 5-DR	66'-1/2"	49225	1/2	5/8	5/8	1 1/8	1 3/8	1 3/8
26	(4) 4-DR & (2) 5-DR	68'-8"	51194	1/2	5/8	5/8	1 1/8	1 3/8	1 3/8
27	(3) 4-DR & (3) 5-DR	71'-3 1/2"	53163	1/2	5/8	5/8	1 1/8	1 3/8	1 3/8
28	(2) 4-DR & (4) 5-DR	73'-11"	55132	1/2	5/8	5/8	1 1/8	1 3/8	1 3/8
29	(1) 4-DR & (5) 5-DR	76'-6 1/2"	57101	1/2	5/8	5/8	1 1/8	1 3/8	1 3/8
30	(6) 5-DR	79'-2"	59070	1/2	5/8	5/8	1 1/8	1 3/8	1 3/8

BTU/HR RATING BASED ON 800 ma T-12 LIGHTING. CASE DESIGNED TO OPERATE IN AN AMBIENT OF 75 °F OR LOWER AND RELATIVE HUMIDITY OF 55% OR LOWER

TABLE 3

ZERO ZONE

**REMOTE REACH-IN COOLER W/ 24" X 63" DOORS
MODEL RI-DCR-63 37 °F TO 41 °F PRODUCT
REFRIGERANT R-22 @ 20 °F EVAPORATOR**

NO. OF DOORS	FREEZER COMBINATIONS	TOTAL LENGTH W/ENDS	BTU/HR	RECOMMENDED LIQUID LINE SIZES EQUIVALENT LENGTH, FEET			RECOMMENDED SUCTION LINE SIZES EQUIVALENT LENGTH, FEET		
				50	100	150	50	100	150
2	(1) 2-DR	4'-8 7/8"	2515	3/8	3/8	3/8	1/2	1/2	1/2
3	(1) 3-DR	6'-8 5/8"	3355	3/8	3/8	3/8	1/2	1/2	1/2
4	(1) 4-DR	8'-8 3/8"	4180	3/8	3/8	3/8	1/2	1/2	5/8
5	(1) 5-DR	10'-8 1/8"	4965	3/8	3/8	3/8	1/2	5/8	5/8
6	(2) 3-DR	13'-1/4"	5958	3/8	3/8	3/8	1/2	5/8	5/8
7	(1) 3-DR & (1) 4-DR	15'-0"	6951	3/8	3/8	3/8	1/2	5/8	5/8
8	(2) 4-DR	16'-11 3/4"	7944	3/8	3/8	3/8	5/8	5/8	7/8
9	(1) 4-DR & (1) 5-DR	18'-11 1/2"	8937	3/8	3/8	3/8	5/8	5/8	7/8
10	(2) 5-DR	20'-11 1/4"	9930	3/8	3/8	3/8	5/8	7/8	7/8
11	(1) 3-DR & (2) 4-DR	22'-10 3/8"	10923	3/8	3/8	3/8	5/8	7/8	7/8
12	(3) 4-DR	25'-3 1/4"	11916	3/8	3/8	3/8	5/8	7/8	7/8
13	(2) 4-DR & (1) 5-DR	27'-2 7/8"	12909	3/8	3/8	3/8	5/8	7/8	7/8
14	(1) 4-DR & (2) 5-DR	29'-2 5/8"	13902	3/8	3/8	3/8	7/8	7/8	7/8
15	(3) 5-DR	31'-2 3/8"	14895	3/8	3/8	3/8	7/8	7/8	7/8
16	(4) 4-DR	33'-6 1/2"	15888	3/8	3/8	3/8	7/8	7/8	7/8
17	(3) 4-DR & (1) 5-DR	35'-6 1/4"	16881	3/8	3/8	1/2	7/8	7/8	7/8
18	(2) 4-DR & (2) 5-DR	37'-6"	17874	3/8	3/8	1/2	7/8	7/8	7/8
19	(1) 4-DR & (3) 5-DR	39'-5 3/4"	18867	3/8	3/8	1/2	7/8	7/8	7/8
20	(4) 5-DR	41'-1/2"	19860	3/8	3/8	1/2	7/8	7/8	1 1/8
21	(4) 4-DR & (1) 5-DR	43'-9 5/8"	20853	3/8	3/8	1/2	7/8	7/8	1 1/8
22	(3) 4-DR & (2) 5-DR	45'-9 3/8"	21846	3/8	3/8	1/2	7/8	7/8	1 1/8
23	(2) 4-DR & (3) 5-DR	47'-9 1/8"	22839	3/8	3/8	1/2	7/8	7/8	1 1/8
24	(1) 4-DR & (4) 5-DR	49'-8 7/8"	23832	3/8	3/8	1/2	7/8	7/8	1 1/8
25	(5) 5-DR	51'-8 5/8"	24825	3/8	1/2	1/2	7/8	1 1/8	1 1/8
26	(4) 4-DR & (2) 5-DR	54'-3/4"	25818	3/8	1/2	1/2	7/8	1 1/8	1 1/8
27	(3) 4-DR & (3) 5-DR	56'-1/2"	26811	3/8	1/2	1/2	7/8	1 1/8	1 1/8
28	(2) 4-DR & (4) 5-DR	58'-1/4"	27804	3/8	1/2	1/2	7/8	1 1/8	1 1/8
29	(1) 4-DR & (5) 5-DR	60'-0"	28797	3/8	1/2	1/2	7/8	1 1/8	1 1/8
30	(6) 5-DR	61'-11 3/4"	29790	3/8	1/2	1/2	7/8	1 1/8	1 1/8

BTU/HR RATING BASED ON 800 mA T-12 LIGHTING. CASE DESIGNED TO OPERATE IN AN AMBIENT OF 75 °F OR LOWER AND RELATIVE HUMIDITY OF 55% OR LOWER

GIAB SPECIFICATION SHEET

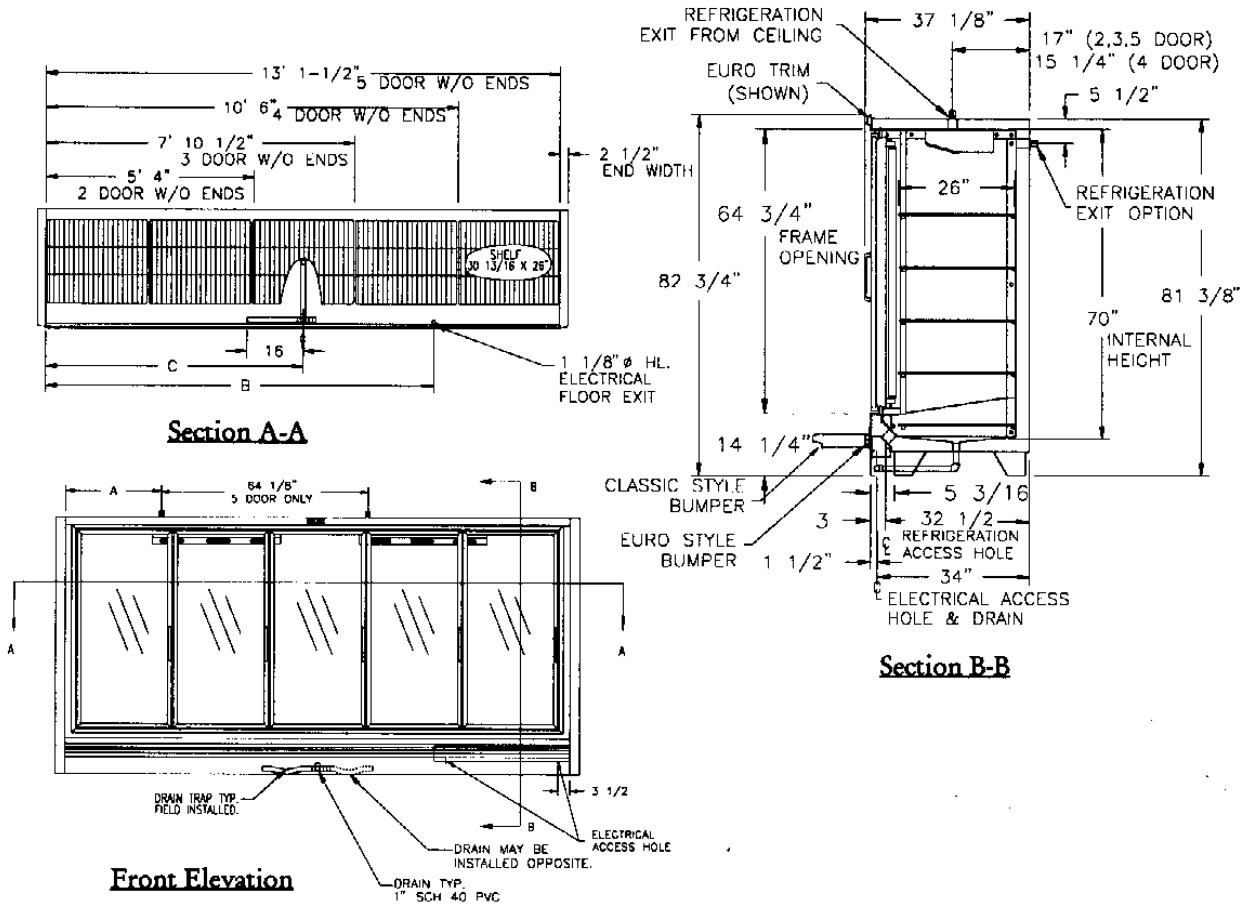

REFRIGERATION LOCATION SCHEDULE			
	A	CONNECTIONS	
		INLET	SUCTION
2 GIAB	14 7/8	3/8 OD	5/8 OD
2 GIAB-F	14 7/8	3/8 OD	5/8 OD
3 GIAB	30 1/8	3/8 OD	5/8 OD
3 GIAB-F	23 7/8	3/8 OD	5/8 OD
4 GIAB	38 1/2	3/8 OD	5/8 OD
4 GIAB-F	38 1/2	3/8 OD	5/8 OD
5 GIAB	30 3/16	3/8 OD	5/8 OD
5 GIAB-F	30 3/16	3/8 OD	5/8 OD

ELECTRICAL CONNECTION (B) & DRAIN (C) LOCATION SCHEDULE			CASE SHIPPING WEIGHT
	B	C	POUNDS
2 GIAB, 2 GIAB-F	25 1/4	32	575
3 GIAB, 3 GIAB-F	55 3/4	47 1/4	873
4 GIAB, 4 GIAB-F	87 1/4	63	1128
5 GIAB, 5 GIAB-F	118 3/4	78 3/4	1440

Figure 5

GIAB-RL SPECIFICATION SHEET

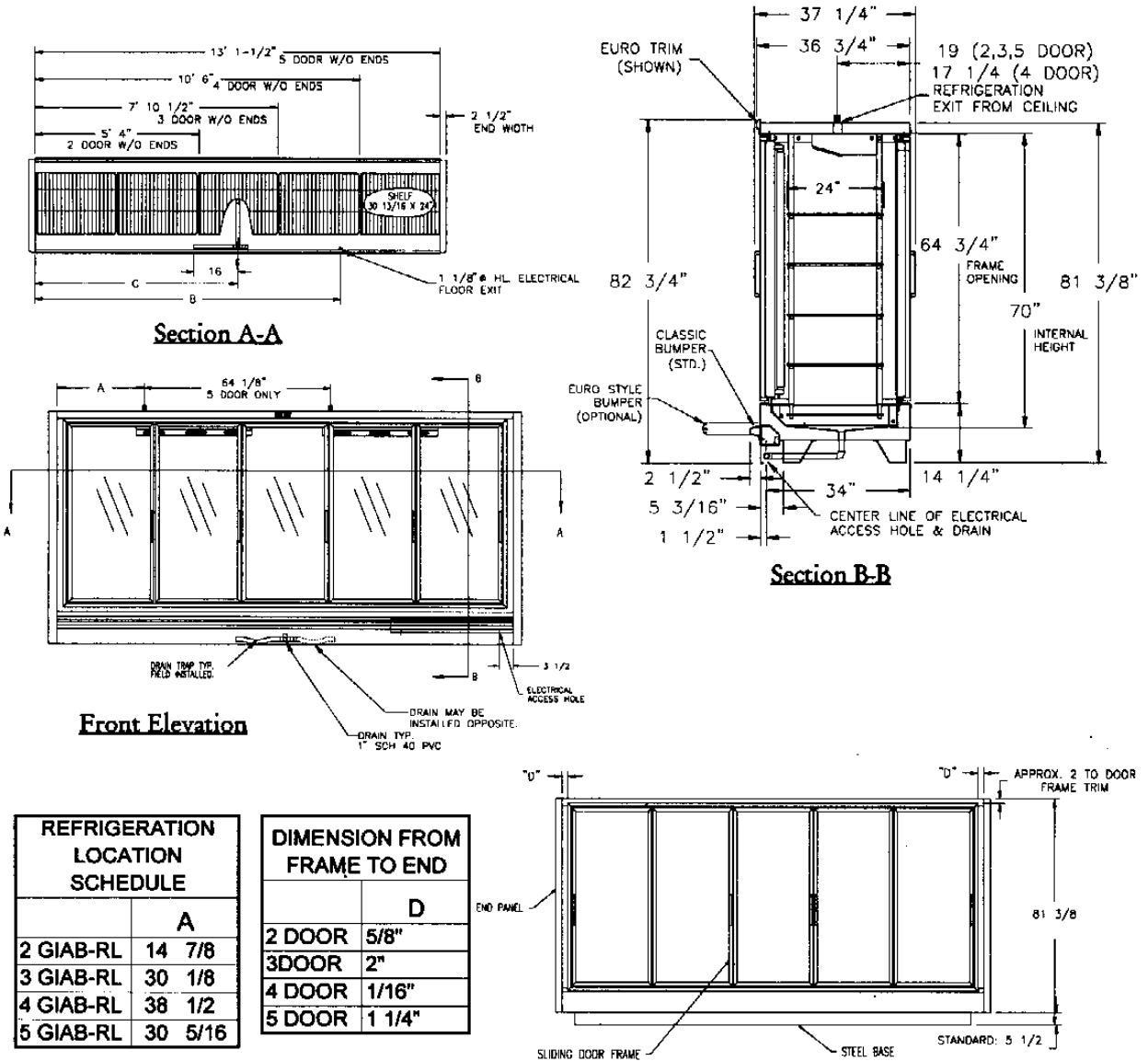

REFRIGERATION LOCATION SCHEDULE	
	A
2 GIAB-RL	14 7/8
3 GIAB-RL	30 1/8
4 GIAB-RL	38 1/2
5 GIAB-RL	30 5/16

DIMENSION FROM FRAME TO END	
	D
2 DOOR	5/8"
3 DOOR	2"
4 DOOR	1/16"
5 DOOR	1 1/4"

	ELECTRICAL CONNECTION (B) & DRAIN (C) LOCATION SCHEDULE		CASE SHIPPING WEIGHT POUNDS
	B	C	
2-GIAB-RL	25 1/4	32	575
3-GIAB-RL	55 3/4	47 1/4	873
4-GIAB-RL	87 1/4	63	1128
5-GIAB-RL	118 3/4	78 3/4	1440

LINE SIZES GIAB-RL
 INLET CONNECTIONS: 3/8"OD
 SUCTIONS CONNECTIONS: 5/8"OD

Figure 6

GIAB-SA SPECIFICATION SHEET

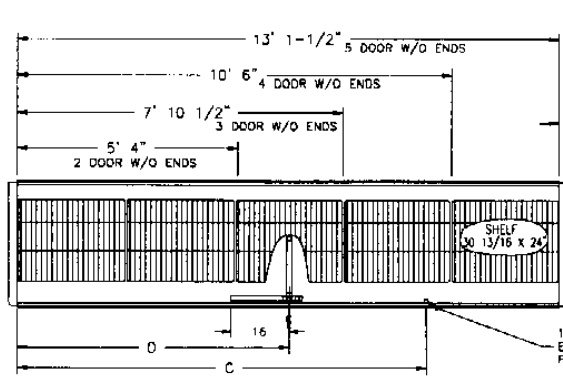

Section A-A

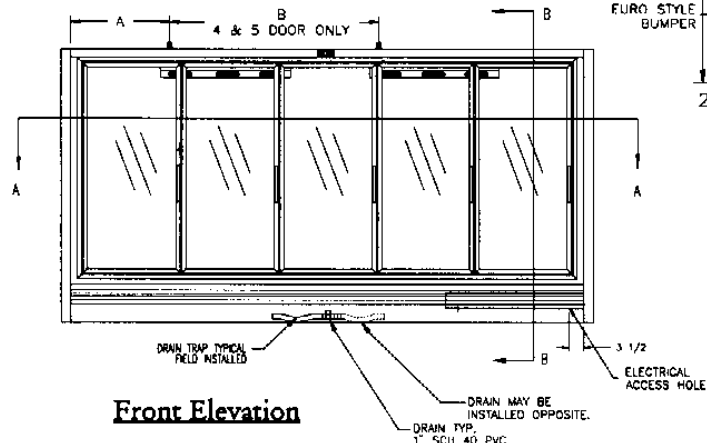

Front Elevation

REFRIGERATION LOCATION SCHEDULE		
	A	B
2 GIAB-SA	8 5/16	N/A
3 GIAB-SA	22 13/16	N/A
4 GIAB-SA	13	53
5 GIAB-SA	19 3/8	72 1/8

	ELECTRICAL CONNECTION (B) & DRAIN (C) LOCATION SCHEDULE		CASE SHIPPING WEIGHT POUNDS
	C	D	
2-GIAB-SA	25 1/4	32	625
3-GIAB-SA	55 3/4	47 1/4	923
4-GIAB-SA	87 1/4	63	1178
5-GIAB-SA	118 3/4	78 3/4	1490

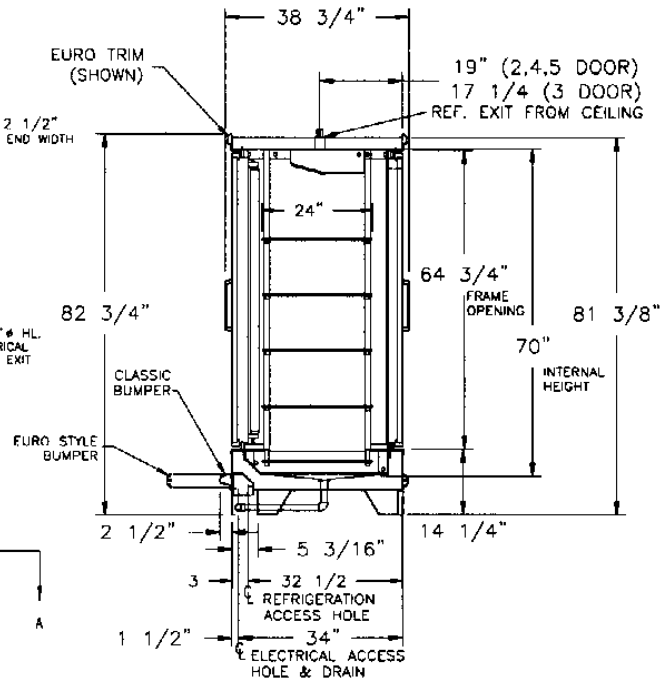

Section B-B

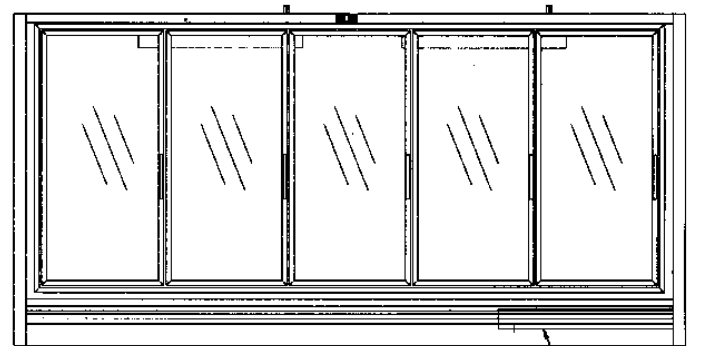

Rear Elevation

LINE SIZES GIAB-SA
 INLET CONNECTIONS: 3/8"OD
 SUCTIONS CONNECTIONS: 5/8"OD

Figure 7

DCR-63 SPECIFICATION SHEET

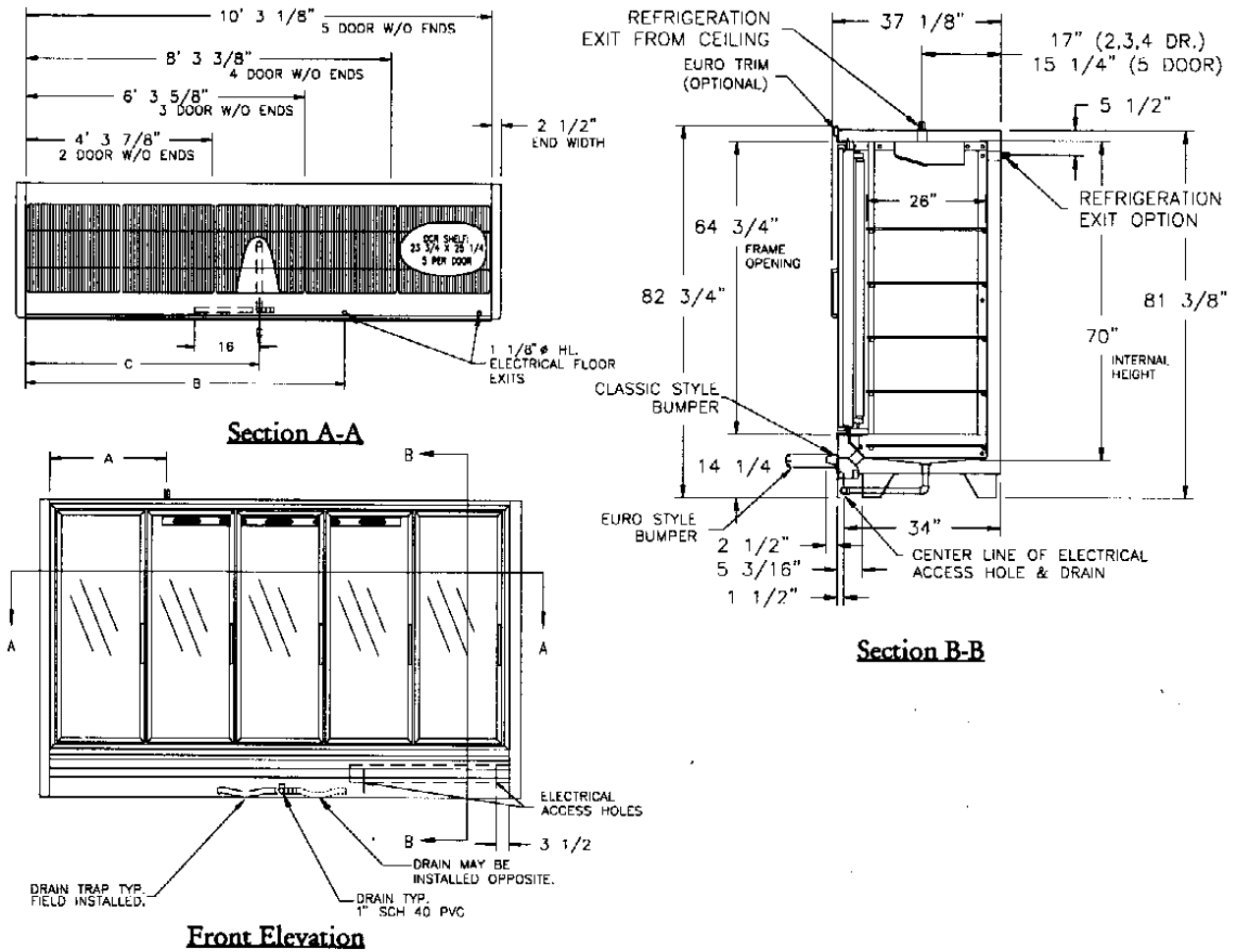

REFRIGERATION LOCATION SCHEDULE	
	A
2 DCR-63	12 5/8
3 DCR-63	24 1/2
4 DCR-63	32 3/16
5 DCR-63	36 7/8

	ELECTRICAL CONNECTION (B) & DRAIN(C) LOCATION SCHEDULE		CASE SHIPPING WEIGHT POUNDS
	B	C	
2 DCR-63	25 1/8	25 15/16	511
3 DCR-63	48 7/8	37 13/16	668
4 DCR-63	72 5/8	49 11/16	820
5 DCR-63	96 3/8	61 9/16	973

REFRIGERANT CONNECTIONS ELECTRICAL DEFROST		
	SUCTION LINE O.D.	LIQUID LINE O.D.
2-5 DCR-63	5/8	3/8

Figure 8

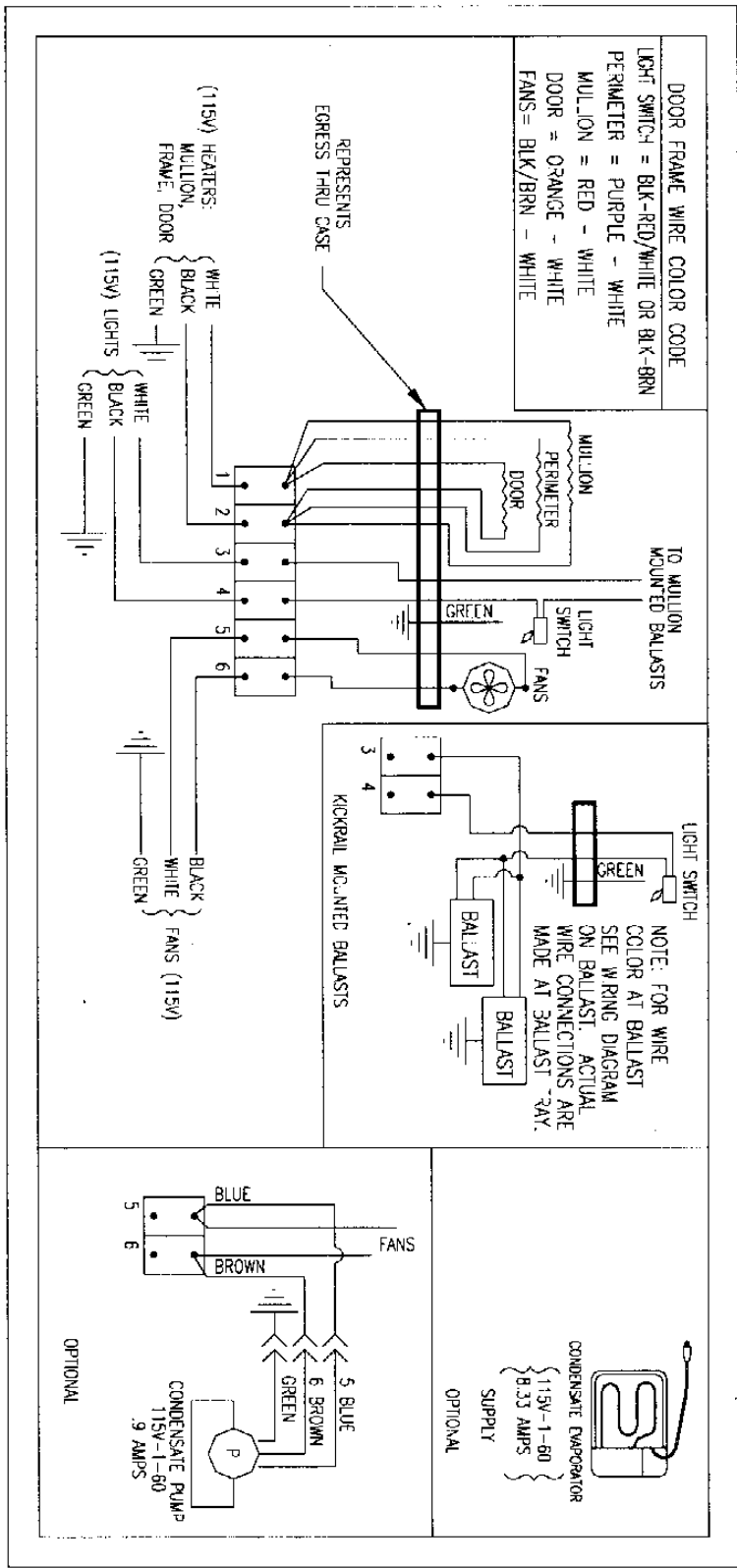

GIAB/DCR-63 Wiring Diagram

Figure 11

ELECTRICAL SPECIFICATIONS FOR GIAB BY DOOR MANUFACTURER									
	FANS AMPS	LIGHT AMPS ONE END*	LIGHT AMPS BOTH ENDS	(T-8) LIGHT AMPS	STD. DOOR	MULLION	FRAME	FRAMELESS DOOR	TOTAL FRAME MULLION STD. DOOR
ANTHONY DOORS									
2-DCR-GIAB	2.4	1.65	2.4	1.45	0.72	0.43	0.95	0	2.10
3-DCR-GIAB	2.4	2.4	3.3	1.94	1.08	0.86	1.12	0	3.06
4-DCR-GIAB	4	3.3	4.05	2.42	1.44	1.29	1.18	0	3.91
5-DCR-GIAB	4.8	4.05	4.8	2.91	1.8	1.72	1.41	0	4.83
ARDCO DOORS									
2-DCR-GIAB	2.4	1.65	2.4	1.89	0.26	0.54	0.36	0	1.16
3-DCR-GIAB	2.4	2.4	3.3	2.34	0.39	0.81	0.44	0	1.64
4-DCR-GIAB	4	3.3	4.05	3.06	0.52	1.08	0.53	0	2.13
5-DCR-GIAB	4.8	4.05	4.8	3.51	0.65	1.35	0.6	0	2.6
COMMERCIAL DOORS									
2-DCR-GIAB	2.4	1.1	1.65	N/A	0.73	0.29	1.35	N/A	2.37
3-DCR-GIAB	2.4	1.65	2.2	N/A	1.09	0.59	1.74	N/A	3.42
4-DCR-GIAB	4	2.2	2.75	N/A	1.46	0.88	1.83	N/A	4.17
5-DCR-GIAB	4.8	2.75	3.3	N/A	1.82	1.17	2.25	N/A	5.24
* STANDARD FOR CASE IN A LINE-UP VOLTAGE: 115 Volts 1 Phase 60 Hz.									

ELECTRICAL SPECIFICATIONS FOR GIAB-RL BY DOOR MANUFACTURER											
	FANS AMPS	LIGHT AMPS ONE END*	LIGHT AMPS BOTH ENDS	(T-8) LIGHTS AMPS	REAR DOOR	REAR FRAME	FRONT STD. DOOR	MULLION	FRAME	FRONT FRAMELESS DOOR	TOTAL FRAME MULLION STD. DOOR
ANTHONY DOORS											
2 DCR-GIAB-RL	2.4	1.65	2.4	1.45	0.74	0.49	0.72	0.43	0.95	0	3.33
3 DCR-GIAB-RL	2.4	2.4	3.3	1.94	1.11	0.8	1.08	0.86	1.12	0	4.77
4 DCR-GIAB-RL	4	3.3	4.05	2.42	1.48	0.98	1.44	1.29	1.18	0	6.37
5 DCR-GIAB-RL	4.8	4.05	4.8	2.91	1.85	1.06	1.8	1.72	1.41	0	7.84
ARDCO DOORS											
2 DCR-GIAB-RL	2.4	1.65	2.4	1.89	0.74	0.49	0.26	0.54	0.36	0	2.39
3 DCR-GIAB-RL	2.4	2.4	3.3	2.34	1.11	0.8	0.39	0.81	0.44	0	3.35
4 DCR-GIAB-RL	4	3.3	4.05	3.06	1.48	0.98	0.52	1.08	0.53	0	4.59
5 DCR-GIAB-RL	4.8	4.05	4.8	3.51	1.85	1.06	0.65	1.35	0.6	0	5.51
COMMERCIAL DOORS											
2 DCR-GIAB-RL	2.4	1.1	1.65	N/A	0.74	0.49	0.73	0.29	1.35	N/A	3.6
3 DCR-GIAB-RL	2.4	1.65	2.2	N/A	1.11	0.6	1.09	0.59	1.74	N/A	5.13
4 DCR-GIAB-RL	4	2.2	2.75	N/A	1.48	0.98	1.46	0.88	1.83	N/A	6.63
5 DCR-GIAB-RL	4.8	2.75	3.3	N/A	1.85	1.06	1.82	1.17	2.25	N/A	8.15
* STANDARD FOR CASE IN A LINE-UP VOLTAGE: 115 Volts 1 Phase 60 Hz.											

GIAB, GIAB-RL Electrical Values

Figure 12



ELECTRICAL SPECIFICATIONS FOR GIAB-SA BY DOOR MANUFACTURER									
	FANS AMPS	LIGHT AMPS ONE ENDS*	LIGHT AMPS BOTH ENDS	(T-8) LIGHTS AMPS	STD. DOOR	MULLION	FRAME	FRAMELESS DOOR	TOTAL FRAME MULLION STD. DOOR
ANTHONY DOORS									
2 DCR-GIAB-SA	2.4	3.3	4.8	2.9	1.44	0.86	1.9	0	4.2
3 DCR-GIAB-SA	4	4.8	6.6	3.88	2.16	1.72	2.24	0	6.12
4 DCR-GIAB-SA	5.6	6.6	8.1	4.84	2.88	2.58	2.36	0	7.82
5 DCR-GIAB-SA	6.4	8.1	9.6	5.82	3.6	3.44	2.82	0	9.86
ARDCO DOORS									
2 DCR-GIAB-SA	2.4	3.3	4.8	3.78	0.52	1.08	0.72	0	2.32
3 DCR-GIAB-SA	4	4.8	6.6	4.68	0.78	1.62	0.88	0	3.28
4 DCR-GIAB-SA	5.6	6.6	8.1	6.12	1.04	2.16	1.06	0	4.26
5 DCR-GIAB-SA	6.4	8.1	9.6	7.02	1.3	2.7	1.2	0	5.2
COMMERCIAL DOORS									
2 DCR-GIAB-SA	2.4	2.2	3.3	N/A	1.46	0.58	2.7	N/A	4.74
3 DCR-GIAB-SA	4	3.3	4.4	N/A	2.18	1.18	3.48	N/A	6.84
4 DCR-GIAB-SA	5.6	4.4	5.5	N/A	2.92	1.76	3.66	N/A	8.34
5 DCR-GIAB-SA	6.4	5.5	6.6	N/A	3.64	2.34	4.5	N/A	10.48
* STANDARD FOR CASE IN A LINE-UP VOLTAGE: 115 Volts 1 Phase 60 Hz.									

ELECTRICAL SPECIFICATIONS FOR DCR-63 BY DOOR MANUFACTURER									
	FANS AMPS	LIGHT AMPS ONE END*	LIGHT AMPS BOTH ENDS	(T-8) LIGHT AMPS	STD. DOOR	MULLION	FRAME	FRAMELESS DOOR	TOTAL FRAME MULLION STD. DOOR
ANTHONY DOORS									
2-DCR-63	2.4	1.65	2.4	1.45	0.6	0.4	0.86	0	1.86
3-DCR-63	2.4	2.4	3.3	1.94	0.9	0.8	0.93	0	2.63
4-DCR-63	3.2	3.3	4.05	2.42	1.2	1.2	1.03	0	3.43
5-DCR-63	4	4.05	4.8	2.91	1.8	1.6	1.22	0	4.62
ARDCO DOORS									
2-DCR-63	2.4	1.65	2.4	1.89	0.24	0.48	0.31	0	1.03
3-DCR-63	2.4	2.4	3.3	2.34	0.36	0.72	0.39	0	1.47
4-DCR-63	3.2	3.3	4.05	3.06	0.48	0.96	0.43	0	1.87
5-DCR-63	4	4.05	4.8	3.51	0.6	1.2	0.53	0	2.33
COMMERCIAL DOORS									
2-DCR-63	2.4	0.55	1.65	N/A	0.6	0.29	1.21	N/A	2.1
3-DCR-63	2.4	1.65	2.2	N/A	0.9	0.59	1.4	N/A	2.89
4-DCR-63	3.2	2.2	2.75	N/A	1.2	0.88	1.72	N/A	3.8
5-DCR-63	4	2.75	3.3	N/A	1.5	1.17	1.85	N/A	4.52
* STANDARD FOR CASE IN A LINE-UP VOLTAGE: 115 Volts 1 Phase 60 Hz.									

GIAB-SA, DCR-63 Electrical Values

Figure 13

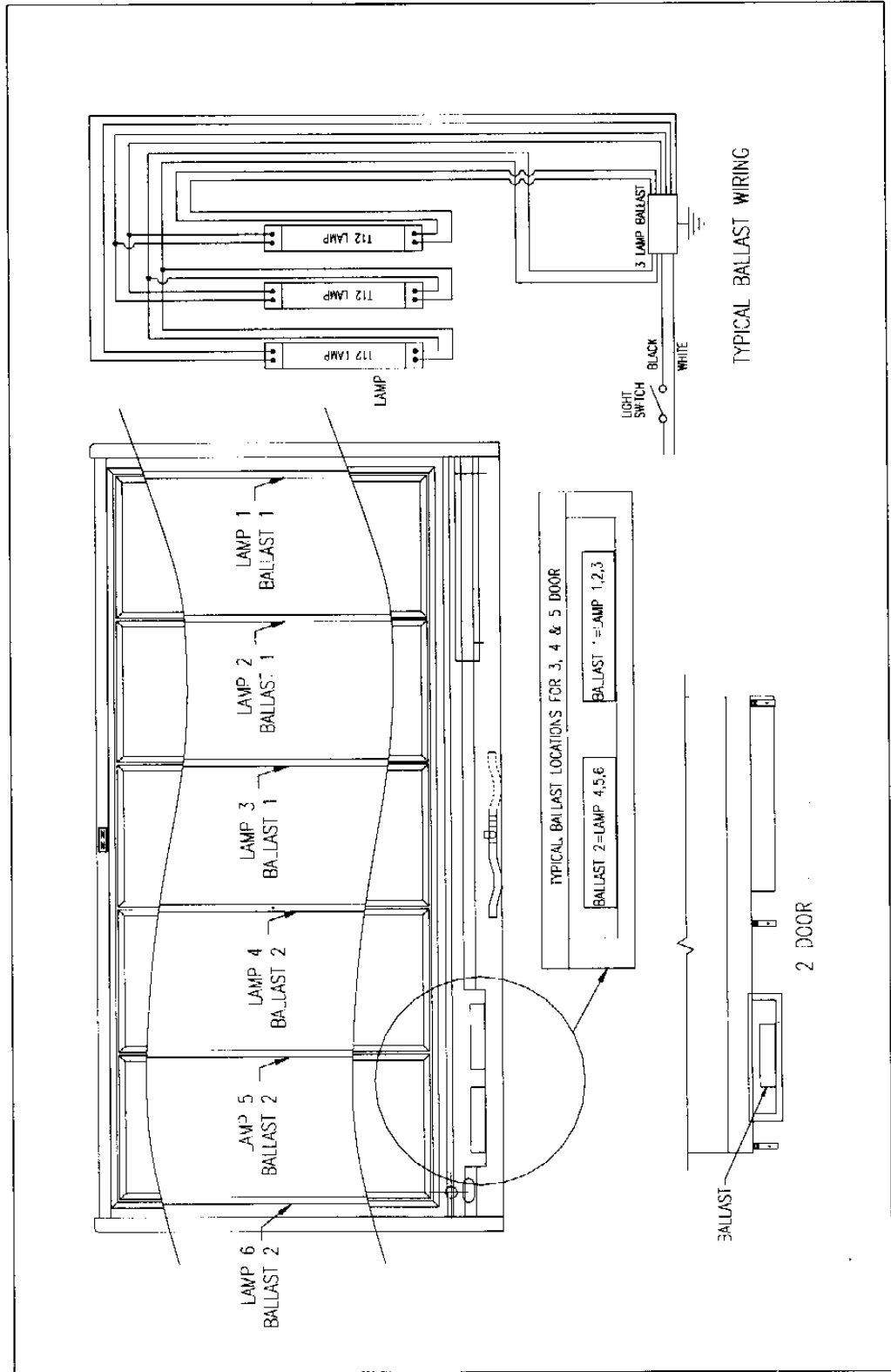

GIAB/DCR-63, LIGHT/BALLAST WIRING DIAGRAM

Figure 18