

SCHOTT Gemtron

INSTALLATION & SERVICE MANUAL



Quik Load doors and frames

Table of contents

- 3-5. Warranty**
- 6. Serial plates**
- 7. Frame installation**
- 8. Door Installation**
- 9. Door removal**
- 10. Reversing the door swing**
- 11. Replacing the door heater**
- 12. Removing and replacing the torque rod**
- 13. Gasket and handle replacement**
- 14. Replacing a frame heater**
- 15. Anti-sweat heater information**
- 16. Blank**
- 17. Replacing light fixtures**
- 18-19. Ballast/power supply replacement and lighting schematics**
- 20. Exploded View – Door**
- 21. Exploded View – Frame T8**
- 22. Exploded View – Frame Gelcore**
- 23. Exploded View – Frame Crossfire**
- 24. Care and cleaning information**



**SCHOTT Gemtron Food Display
WARRANTIES AND GENERAL TERMS AND CONDITIONS**

CONDITIONAL ACCEPTANCE OF ORDER: SCHOTT Gemtron Corporation's ("SCHOTT Gemtron") acceptance of customer's order and therefore, the formation of a valid contract for sale, is EXPRESSLY CONDITIONED on Customer's acceptance of the general terms and conditions as set forth herein and any additional terms and conditions indicated on the face of SCHOTT Gemtron's Conditional Acceptance of Order or quotation. Customer will be deemed to have accepted these general terms and conditions and any general terms and conditions indicated on the face of SCHOTT Gemtron's Conditional Acceptance of Order or quotation unless customer shall object thereto in writing within five days from receipt of SCHOTT Gemtron's Conditional Acceptance of Order or quotation or upon acceptance of all or any parts of the goods ordered, whichever occurs first.

ADDITIONAL TERMS AND CONDITIONS: The terms and conditions as set forth on SCHOTT Gemtron's Conditional Acceptance of Order, quotation, or price lists shall be considered additional terms and conditions of this sale. SCHOTT Gemtron and the purchaser acknowledge that all of the terms and conditions applicable to this sale reflect an acceptable allocation of the rights and obligations of the parties to this sale.

SHIPMENT OF GOODS / RETURN OF GOODS: Every effort will be made to ship the goods on the scheduled shipment date and to maintain production schedules consistent therewith. SCHOTT Gemtron will not be liable, however, for any claims arising from the failure to meet any scheduled shipping dates. If Buyer refuses shipment of any standard catalog products under an acknowledged order and those products are consistent with that order and are not delivered damaged or defective, then Buyer will be responsible for:

1. Return shipment of the products to SCHOTT Gemtron in original shipping containers;
2. Return freight to SCHOTT Gemtron prepaid by Buyer; and
3. A restocking charge to be determined by SCHOTT Gemtron of not less than twenty-five percent (25%) of the sales price. Buyer assumes the risk of any return shipment damage or loss, the cost of which will be assessed by SCHOTT Gemtron and added to the restocking charge. No custom products or custom sizes of catalog items may be returned to SCHOTT Gemtron for credit unless those products are not consistent with an acknowledged order or they are defective. If they are defective, SCHOTT Gemtron reserves the right to correct the defect at the ship-to location.

TERMS OF CREDIT: All credit terms are net 30 days from date of invoice. Any deductions from the net invoice amount must be approved by an authorized representative of SCHOTT Gemtron. If credit is extended to Buyer, SCHOTT Gemtron reserves the right to revoke such credit if Buyer fails to make timely payment for any goods delivered. SCHOTT Gemtron reserves the right to require payment or other assurances which it deems necessary prior to the shipment of any goods, if, in SCHOTT Gemtron's opinion, exercised in SCHOTT Gemtron's subjective, good faith judgment, the Buyer's financial condition has deteriorated or the risk of non-payment has otherwise increased. Credit is subject to approval upon receipt of completed credit application. Any goods shipped prior to credit approval shall be shipped "Cashiers Check", or pre-payment. A \$50.00 charge will be applied for each returned check. Goods may not be returned for credit unless prior authorization and an authorization number have been granted by SCHOTT Gemtron. A 1-1/2% per month charge will be assessed on past due amounts.

SCHOTT Gemtron Food Display • 2840 Nebo Road, Madisonville, KY 42431

Toll Free: 800.326.2717 • Phone: 270.821.2864 • Fax: 270.326.3624

FWTC1011

6/25/08 Rev. A

SCHOTT Gemtron

LIMIT ON REMEDIES IN EVENT OF FAILURE: In the event any SCHOTT Gemtron product fails to perform as warranted, SCHOTT Gemtron's sole responsibility and PURCHASER'S SOLE AND EXCLUSIVE REMEDY under any warranty, contract, negligence or other claim of liability shall be limited to a refund of SCHOTT Gemtron's original selling price or, at SCHOTT Gemtron's option, furnishing the purchaser with another product without charge F.O.B. Madisonville, Kentucky. In no event shall SCHOTT Gemtron be liable for cost incurred in the removal of failed products, the installation of replacement products, OR ANY INCIDENTAL OR CONSEQUENTIAL DAMAGES INCURRED AS NON-PERSONAL INJURY LOSSES. In the event a product is replaced pursuant to any applicable SCHOTT Gemtron warranty, the replacement product is warranted only for the remainder of the warranty period applicable to the original product. SCHOTT Gemtron shall not be liable for any allegedly defective product unless SCHOTT Gemtron first has the right to inspect such product and verify the defective condition.

CLAIMS BY BUYER: All claims by Buyer against SCHOTT Gemtron, including claims for alleged shortages, must be made in writing and delivered to SCHOTT Gemtron within 30 days of receipt of the goods. SCHOTT Gemtron shall thereupon be afforded a reasonable opportunity to inspect the goods. All claims not made in the time period and manner specified above shall be deemed waived. All actions, claims or defenses by Buyer shall be deemed waived unless commenced or asserted within 6 months of receipt of the goods.

WARRANTY: The following shall be the sole and exclusive warranty for products sold by SCHOTT Gemtron Food Display with the exception of the SCHOTT Gemtron Food Display Limited Warranty (Form No. W1010): SCHOTT Gemtron warrants to Customer that all Products will conform to and perform in accordance with the applicable current specifications issued by SCHOTT Gemtron. This warranty shall not apply to any Product that shall have been subject to misuse, abuse, accident, disaster, or which has been used contrary to current instructions.

THE FOREGOING WARRANTIES ARE THE SOLE WARRANTIES, EXPRESS OR IMPLIED, GIVEN BY SCHOTT GEMTRON IN CONNECTION WITH THE PRODUCTS, AND SCHOTT GEMTRON DISCLAIMS ALL OTHER WARRANTIES, INCLUDING WARRANTIES OF MERCHANTABILITY, FITNESS FOR A PARTICULAR PURPOSE AND NON-INFRINGEMENT OF THIRD PARTY RIGHTS.

SCHOTT Gemtron assumes no liability for consequential damages, anticipated or lost profits, incidental damages, loss of time, or other losses incurred by Customer or any third party in connection with the Products.

SUITABILITY OF PRODUCTS: Purchaser shall be solely responsible for determining the suitability for use of the products purchased from SCHOTT Gemtron. Representations by employees or agents of SCHOTT Gemtron (other than the warranties specified herein) concerning the suitability of SCHOTT Gemtron's products are not authorized by SCHOTT Gemtron and may not be relied upon by the purchaser.

PERMISSIBLE VARIATIONS, STANDARDS AND TOLERANCES: Except in the particulars specified by purchaser and expressly agreed to in writing by SCHOTT Gemtron, all material shall be produced in accordance with SCHOTT Gemtron's standard practices. All material, including that produced to meet an exact specification, shall be subject to tolerances and variations consistent with usages of the trade and regular factory practices concerning dimension, weight, straightness, section, composition and mechanical properties, normal variations in surface, internal conditions and quality, and deviations from tolerances and variations consistent with practical testing and inspection methods.

SCHOTT Gemtron Food Display • 2840 Nebo Road, Madisonville, KY 42431

Toll Free: 800.326.2717 • Phone: 270.821.2864 • Fax: 270.326.3624

FWTC1011

6/25/08 Rev. A

SCHOTT Gemtron

CHANGES IN ORDER: SCHOTT Gemtron reserves the right to void any quotation for price or terms in the event the customer to whom such quotation is made changes his order with respect to any factor reflected in price or other terms originally ordered or quoted.

CHANGES BY SCHOTT GEMTRON: SCHOTT Gemtron reserves the right to change design, colors and specifications of any goods without notice to Buyer.

DEFAULT: If Buyer defaults on the purchase of any goods or if a petition in bankruptcy is filed by or against Buyer, SCHOTT Gemtron, in addition to other remedies, may repossess any goods which were previously delivered and for which payment has not been received and may refuse to make further shipment of goods. Buyer agrees to pay SCHOTT Gemtron's costs and expenses of collection or repossession including the maximum attorney's fee permitted by law.

WE ASSUME NO RESPONSIBILITY FOR BREAKAGE IN TRANSIT: Breakage on arrival should be noted on Bill of Lading and a claim filed PROMPTLY with carrier.

PREVAILING PRICE: Unless specifically indicated otherwise in writing, all orders are deemed to be at the price prevailing at the date of shipment.

FINAL ACCEPTANCE OF ORDERS: All orders are subject to final acceptance at SCHOTT Gemtron's office in Madisonville, Kentucky. Conditional acceptance is evidenced by SCHOTT Gemtron's Conditional Acceptance of Order or shipment of the ordered products and final acceptance is effective according to the provisions herein.

CHANGE OF TERMS: Prices, terms and conditions of sale are subject to change without notice.

PRICE QUOTATIONS: All prices are quoted in U.S. dollars.

PAYMENT OF TAXES: Any federal, state or municipal tax imposed by virtue of the sale hereunder shall be added to the invoice and paid by the purchaser without discount.

FORCE MAJEURE. Except for the payment of money, neither party shall be held responsible for any delay or failure in performance of any part of this Agreement to the extent that delay or failure is caused by causes beyond its control ("Force Majeure Conditions"), including, but not limited to, fire, flood, explosion, war, strike, embargo, government requirement, civil or military authority, act of God, act or omission of carriers or other similar causes. If any Force Majeure Condition occurs, the party delayed or unable to perform ("Delayed Party") shall give immediate notice to the other party ("Affected Party"), and the Affected Party, upon giving prompt notice to the Delayed Party, shall be excused from performance under this Agreement for the duration of the Force Majeure Condition, provided, however, that the Affected Party shall take all reasonable steps and cooperate with the Delayed Party to avoid or remove the cause of non-performance and shall resume performance hereunder with dispatch when the cause is removed; and provided further that if the Delayed Party cannot within sixty (60) days remove the cause of non-performance, the Affected Party may terminate this Agreement.

NON-WAIVER: Waiver by SCHOTT Gemtron of a breach of any of the terms and conditions of this sale shall not be construed as a waiver of any other breach. The mere passage of time shall not constitute a waiver under the terms and provisions of this sale.

WAREHOUSING: Prices in our price lists are for quantities ordered for production and shipment at one time. The warehousing charge of 1-1/2% per month will be applied to invoices covering material which has not been picked up or released for shipment within thirty days after notification that the order is ready.

SCHOTT Gemtron Food Display • 2840 Nebo Road, Madisonville, KY 42431

Toll Free: 800.326.2717 • Phone: 270.821.2864 • Fax: 270.326.3624

FWTC1011

SCHOTT Gemtron

CANCELLATIONS: Cancellation of any acknowledged order from SCHOTT Gemtron must be approved in writing by SCHOTT Gemtron Food Display in Madisonville, Kentucky. SCHOTT Gemtron shall be entitled to receive, upon demand, liquidated damages of not less than 10 percent (10%) of the purchase price of the order, plus the cost of all materials and work furnished or done upon time of the cancellation by the purchaser.

SEVERABILITY: If any provision of the terms and conditions specified herein shall be deemed invalid or unenforceable, the remaining terms and conditions shall be construed as though such provision does not appear herein and shall be otherwise fully enforceable.

MODIFICATION: No distributor, representative, agent or employee has the authority to alter or change any product warranty, either orally or in writing.

SCHOTT Gemtron Food Display • 2840 Nebo Road, Madisonville, KY 42431
Toll Free: 800.326.2717 • Phone: 270.821.2864 • Fax: 270.326.3624
Email: info@gemtronfooddisplay.com • www.gemtronfooddisplay.com

FWTC1011
Page 4 of 4

Serial plate

To assist our customer with technical information or ordering spare parts, frames and doors have a serial plate which informs about Type number, manufacture date, order number and electric ratings.

Frame Serial Plate

 US RECOGNIZED 17MR COMPONENT - DOOR PANEL ASSEMBLIES GEMTRON CORPORATION 1-800-326-2717 WWW.GEMTRONFODDISPLAY.COM	120 VOLT 60 HZ	MODEL: 859710-1
	RATING: 2.95 AMP	BOM: 54**52969LTLDBK
	LIGHT RATING: 1.83 AMP	WORK No: M302060/C02675
	ADD DOOR FOR TOTAL AMP	PROD DATE: 2008-01-21

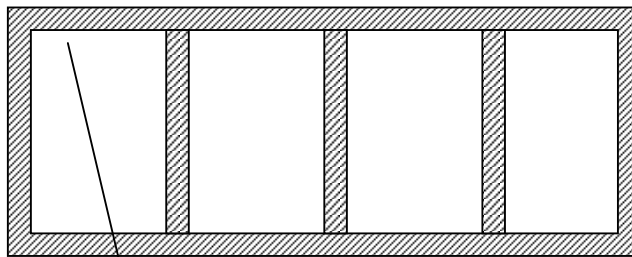

Frame Serial Plate

Door serial plate is located on the top or on the hinge side of door

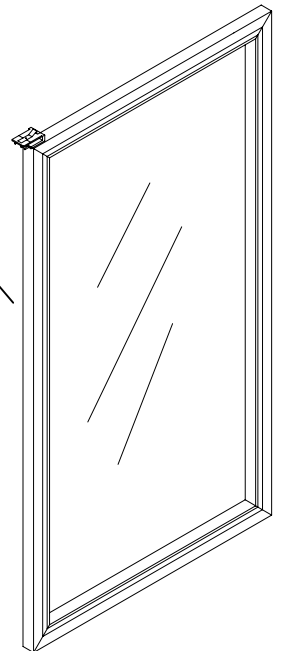

Door Serial Plate

 US RECOGNIZED 17MR COMPONENT - GLASS DOOR ASSEMBLIES GEMTRON CORPORATION 1-800-326-2717 WWW.GEMTRONFODDISPLAY.COM	120 VOLT 60 HZ	MODEL: 859706-1
	RATING: .25 AMP	BOM: 54**2969LTRHBK
		WORK No: M302060/C02675
		PROD DATE: 2008-01-21

Frame Installation

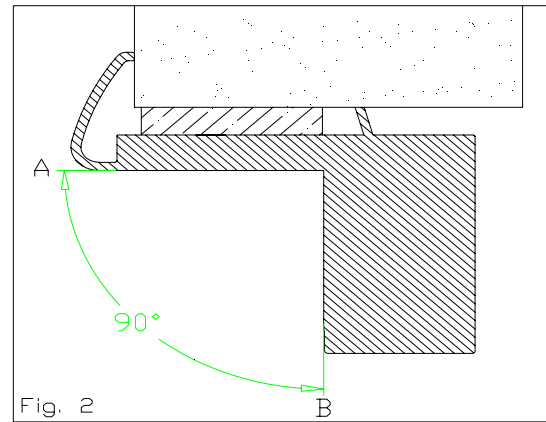
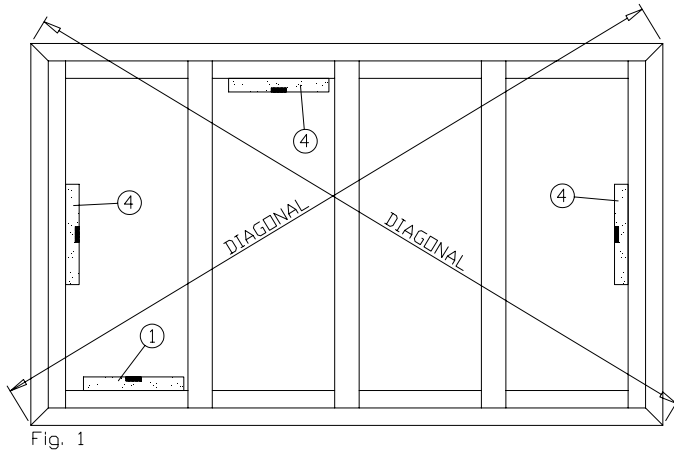

1. Place frame into opening in the panel. Clamp top of frame. Check horizontal alignment with a level (1), then fasten bottom of frame with mounting screws.
2. Use spacer at the upper horizontal to prevent distortion of frame (Fig 2). Attention! Make sure that the gap is filled, to keep the profile from bending out. Surface "A" and "B" must be keep at 90°.
3. Make sure both diagonals are equally long.
4. Check vertical and horizontal sides with a level (4). Fasten the side profiles and the upper vertical with mounting screws. Any gaps between the frame and cooler/freezer wall needs to be insulated with sealant to prevent air leaks.

Installing a Door

1. Handling each door carefully, install them into the frame, one at a time by inserting the torque rod-end into the cavity of the torque adjuster.
2. Tilt the top of the door up and toward the frame, inserting the hinge pin into the Gib, located in the top of the door frame making sure that the spring clip engages into the upper frame rail.
3. Insert the hold-open bolt through the elongated hold-open slot and into the frame mounting hole. Tighten with a Phillips-head screwdriver.
4. Adjust the door swing and door squareness by adjusting the torque adjuster. (see Torque and Sag Adjustment)

NOTE: Do not use power tools to adjust the torque adjuster.

NOTE: Do not over-tighten the hold-open bolt (torque to 45-51 inch pounds). Be certain that the hold-open does not bind while sliding along the hold-open bolt and adjust as necessary.

1.



2.



3.



Torque and Sag Adjustment

The torque adjuster regulates the door squareness and tension of the door swing.

1. Use the flathead screwdriver, adjust the torque rod tension by turning the outside screw on the torque adjuster.
 - Turn counter-clockwise to increase tension.
 - Turn clock-wise to decrease the tension.
2. Adjust the door sag to square it in the frame by turning the screw that is marked SAG ADJ. (sag adjustment), on the end of the torque adjuster, until the door slowly closes itself.
 - Turn the screw clockwise to lower the handle side of the door.
 - Turn the screw counter-clockwise to raise the door's handle side.

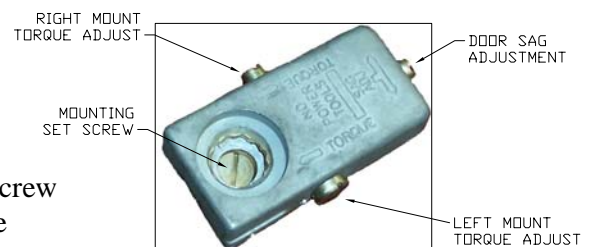

NOTE: Do not use power tools when adjusting the torque adjuster. To check for proper door closing tension, open the door approximately 1 inch and release the door. The door should self close without any assistance.

Removing a Door

1. Using a flat-head screwdriver, turn the adjustment screw on the front of the torque adjuster clockwise until the door no longer self-closes.



2. Open the door to access the hold-open device and remove the mounting bolt from the frame using a Phillips-head screwdriver.



3. With the door in a nearly closed position, insert the top half of the needle-nose pliers into the grip hole in the hinge pin spring clip and the bottom half of the pliers beneath the hinge pin shroud.



4. Squeeze the pliers to pull down the spring clip, while simultaneously pulling the top of the door away from the frame and pull the top of the door out.

5. Lift and remove the door from the torque adjuster.



NOTE: Exercise caution when handling the door.

Reversing the Door Swing

1. Using a flat-head screwdriver, loosen the torque adjuster from its mount by turning the center mounting screw counter-clockwise less than one-half (1/2) of a turn.
2. Remove the torque adjuster, exposing the mounting hole in the bottom frame rail.
3. Locate the mounting hole at the opposite side of the door opening.
4. Using the flat-head screwdriver, carefully pry underneath the plug cap and remove it.
5. Place the torque adjuster on the newly opened mounting hole, aligning the flanged corners of the mounting tabs.
6. Insert the torque adjuster mounting tabs onto the mounting hole with the hollow end of the torque adjuster against the door frame.
7. Confirm that the mounting flanges on the bottom of the torque adjuster align with the corner mounting slots of the mounting hole in the frame.
8. Using a flat-head screwdriver, turn the torque adjuster mounting set-screw clockwise, for 1/2 a turn, to tighten the mount and lock it in place. Confirm that the torque adjuster mounting is flush with the door frame.
9. Using a Phillips head screwdriver, loosen and remove the hold-open bolt from the top frame rail.
10. Relocate and install the hold-open shoulder bolts into the opposite hold-open mount of the same door frame.
11. Open the vertical side access to the hinge pin wire connections in the rail on the hinge side of the door assembly.
12. Disconnect the Hot, Neutral and Ground wires of the hinge pin from the heater wire circuit and the ground terminal.
13. Completely remove the hinge pin assembly from the top door rail.
14. Using a plastic mallet and a flat-head screwdriver, remove the torque rod from the bottom of the door assembly.
15. Swap placement of the Hinge Pin and Torque Rod to the other's original mounting hole in the door assembly hinge side rail.
16. Reinstall the hinge pin and the torque rod completely into the ends of the door assembly hinge rail.
17. If necessary, lightly tap on the hinge pin and torque rod with a plastic or rubber mallet until each is fully seated into the top and bottom of the door.
18. Reconnect the hinge in wires and confirm that all connections are secure.
19. Check and confirm torque rod and hinge pin are correctly and completely installed.
20. Reinstall the door into the frame.

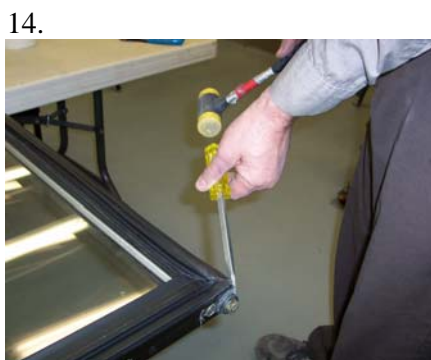
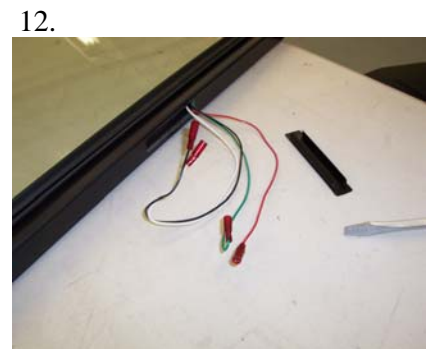

Door heater replacement

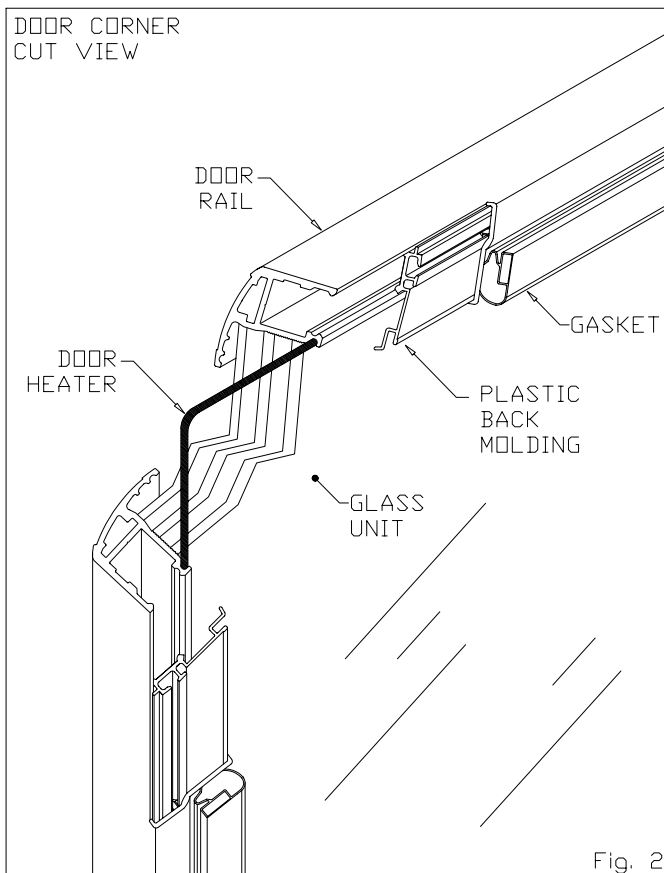
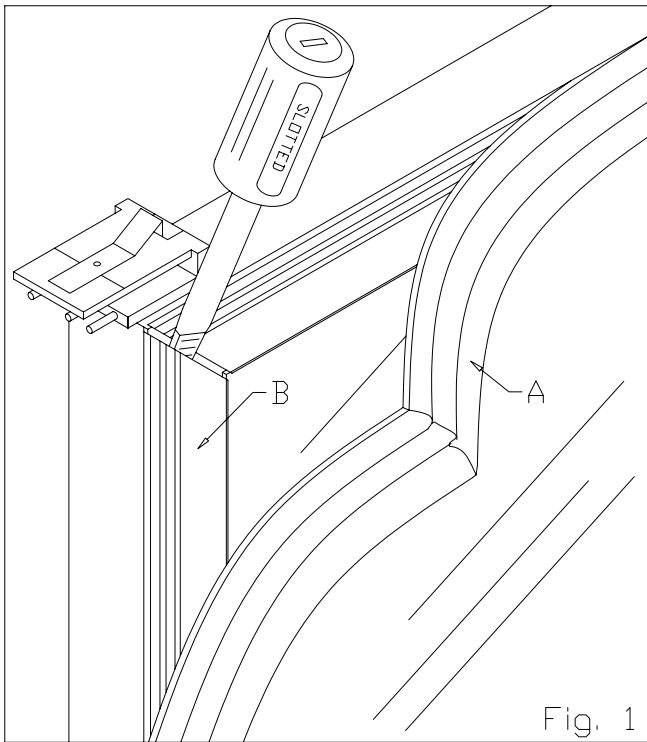

1. Disconnect frame from power source. Remove the door. Remove the magnetic gasket (A) by starting on the upper corner and work your way down. Carefully remove plastic (B) cover with a screwdriver, starting at the upper corner (Fig. 1). If plastic cover becomes damaged it has to be replaced.
2. Refer to Fig. 2 for heater wire location. Remove the heater from the door rail, and cut the leads at the hinge pin power connection.
3. Starting at the upper hinge side corner, run the new heater around the door, pressing the heater into the aluminum channel the old one was removed from.
4. Connect the new heater to the hinge pin leads as shown in Fig. 3.
5. Carefully replace the plastic back molding. Reinstall the gasket (see gasket replacement instructions). Reinstall the door (see door installation instructions).

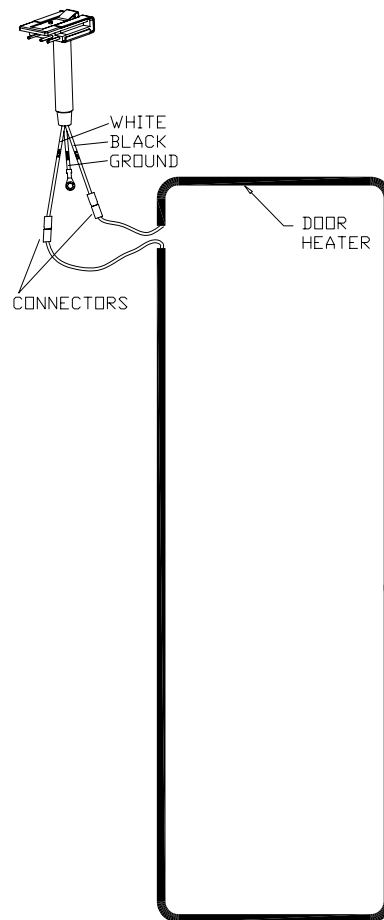

Removing and Replacing the Torque Rod

1. Carefully place a flathead screwdriver between the door rail and the washer beneath the torque rod. (A)
2. Dislodge the torque rod from the door by pushing on the torque rod or tap it loose using a plastic or rubber Mallet. (B)
3. Once dislodged pull the torque rod completely out of the door.
4. Reinstall a new torque rod by inserting it into the same hole fully seating it with a plastic or rubber mallet. (C)

A



B

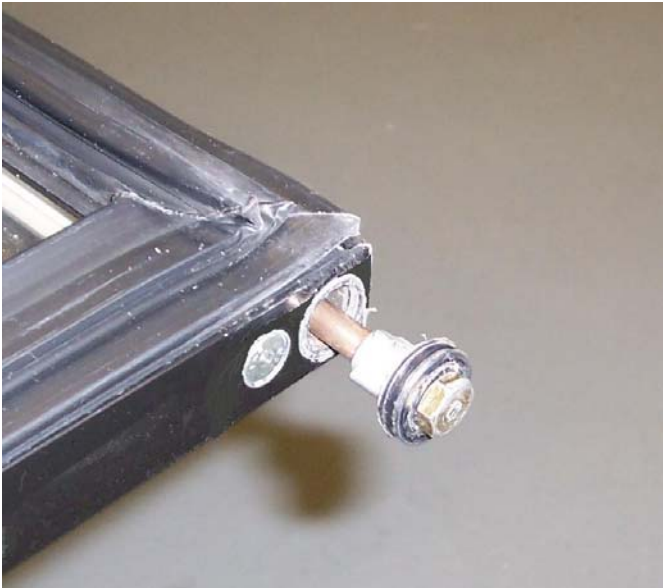

C



Gasket replacement

1. Remove the magnetic gasket (A) by starting on the upper corner and work your way down (Fig. 1).
2. To install a gasket, insert the lip around the inner edge of the gasket into the groove in the plastic on the back of the door (B), then press the dart on the back of the gasket into the plastic on the back of the door (C) (Fig. 2).

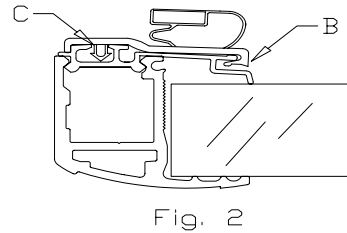
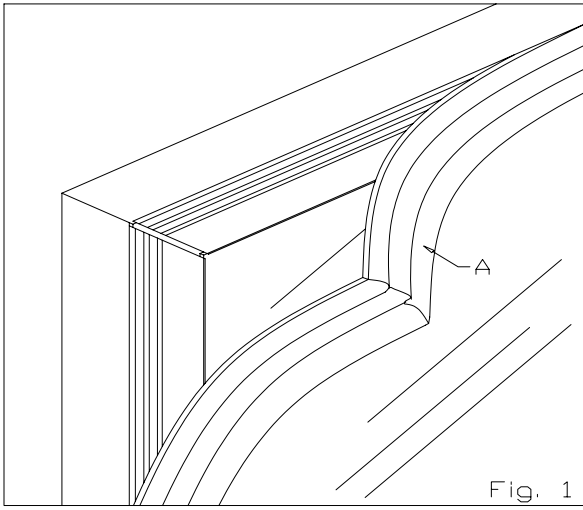

Handle replacement

1. Remove the gasket (A) as much as necessary to access the cut-outs (B) in the plastic, this will allow access to the handle mounting screws (C) (Fig. 1).
2. Reinstall gasket (see gasket replacement instructions).

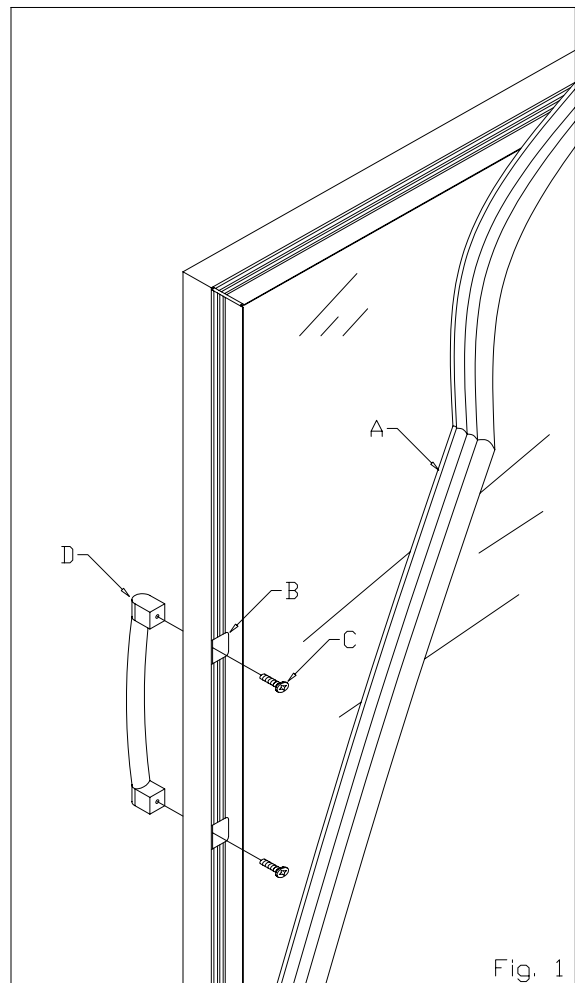

Replacing a frame heater

1. Disconnect the frame from its power source. Remove the doors, following the instructions in the “Door removal” section of this book. Refer to section 7, “Anti-sweat heater wiring diagram” for information on electrical connection locations and heater part numbers.
2. Remove the plastic profiles covering the defective heater by first removing the horizontal pieces, then the vertical pieces. Use a screwdriver to carefully release the profiles (Fig. 2). **Caution:** Do not damage the plastic during removal.
3. Cut the defective heater approximately 8 inches from its end, and remove it from the frame (Fig. 3).
4. Press the new heater into place using your finger. Be careful not to damage the insulation on the heater. Splice the heaters using line-to-line connectors (Fig. 4). **WARNING! Only an authorized technician should perform heating cable replacement.**
5. To replace the plastic profiles (covers), begin with the vertical covers then move on to the horizontal ones. To replace the plastic profiles on the mullions, begin by hooking the plastic cover on the right side of the mullion (Fig. 5A). Replace the metal cover, ensuring that it fits properly under the plastic cover (Fig. 5B). Then install the left plastic cover on to the mullion, using a rubber mallet to get it into position (Fig. 5C). If getting the cover into position is difficult, try hammering on both sides of the mullion. Be careful not to damage the plastic.
6. To replace the vertical and horizontal covers, begin by installing the plastic cover on to the metal cover (Fig. 6A). Install the metal cover on to the frame (Fig. 6B). Use a rubber mallet to position the plastic cover on to the frame (Fig. 6C). For the covers to lock to the frame properly, the metal must be inserted into the plastic correctly (Fig. 7)
7. Reinstall the doors following the “Door installation” instructions, and reconnect the frame to its power source.

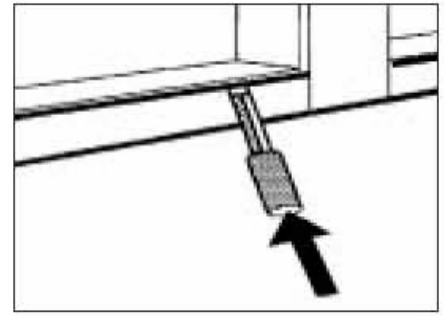

Fig.2

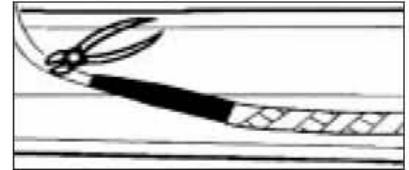

Fig. 3

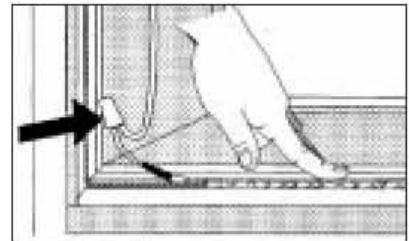

Fig. 4

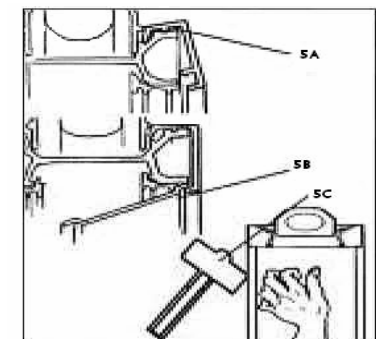

Fig. 5

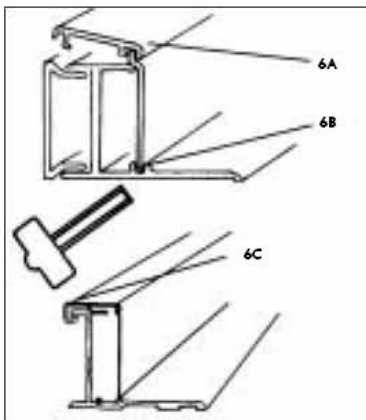

Fig. 6

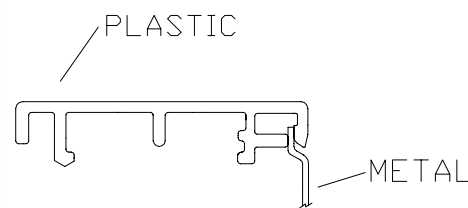

Fig. 7

Replacing Lighting

T8 lighting

1. Disconnect the frame from its power source.
2. Press together lamp cover and twist outwards.
3. Twist light tube 90° clockwise or counter clockwise and remove it.
4. Install new light tube and reinstall lamp cover.

Attention! It is important that the lamp cover fits tightly against the frame. If air leaks in, light tube efficiency decreases.

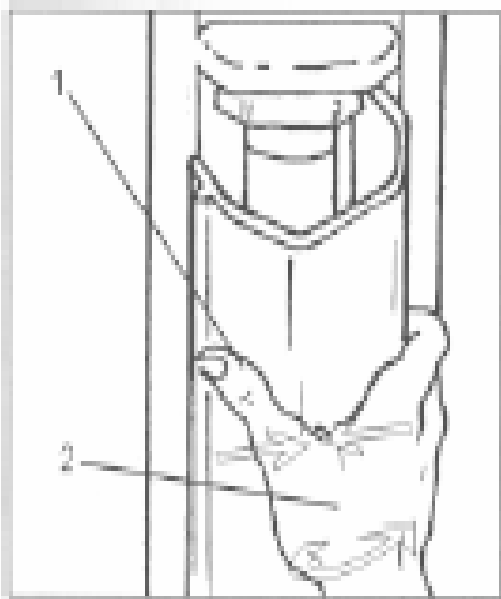

Gelcore LED lighting

1. Disconnect the frame from its power source.
2. Use your thumb to press down on one side of the mounting clip.
3. Twist the LED fixture out of the mounting clip.
4. The new LED fixture will snap into the existing mounting clip.

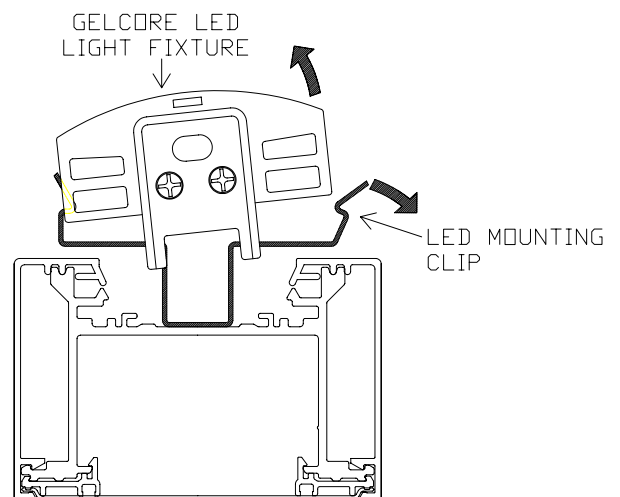
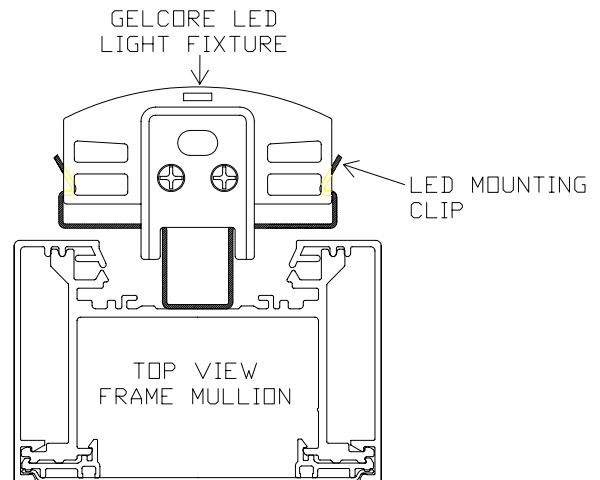

Crossfire LED lighting

1. Disconnect the frame from its power source.
2. Remove the mounting screws at the top and bottom of the LED fixture.
3. The new LED fixture will mount using existing screws and mounting holes.

Replacing a T8 ballast or Gelcore LED power supply

1. Disconnect the frame from its power source.
2. Remove the ballast/power supply cover (A) located on the side of the mullion. Then remove the ballast/power supply (B).
3. If quick connect plugs (C) are present, use them to disconnect the wiring and replace the ballast/power supply. If the plugs are not provided, the wires must be cut at a length you can comfortably connect the new power supply. (see LED and T8 wiring diagrams for detailed information on ballast/power supply wiring)
4. Reinstall the ballast/power supply (B) and cover (A). Reconnect the frame to its power source.

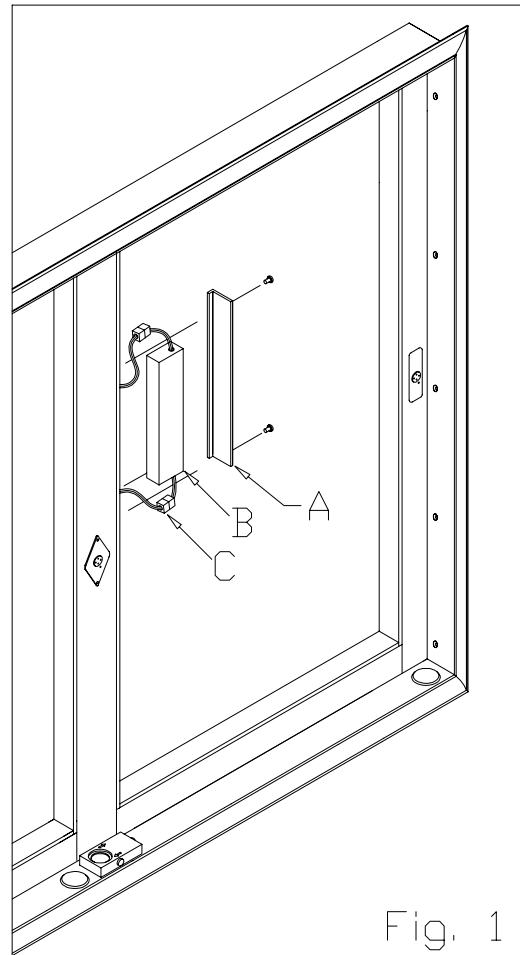

Note: The power supply for Crossfire LED lighting is built into the LED light fixture.

Fig. 1

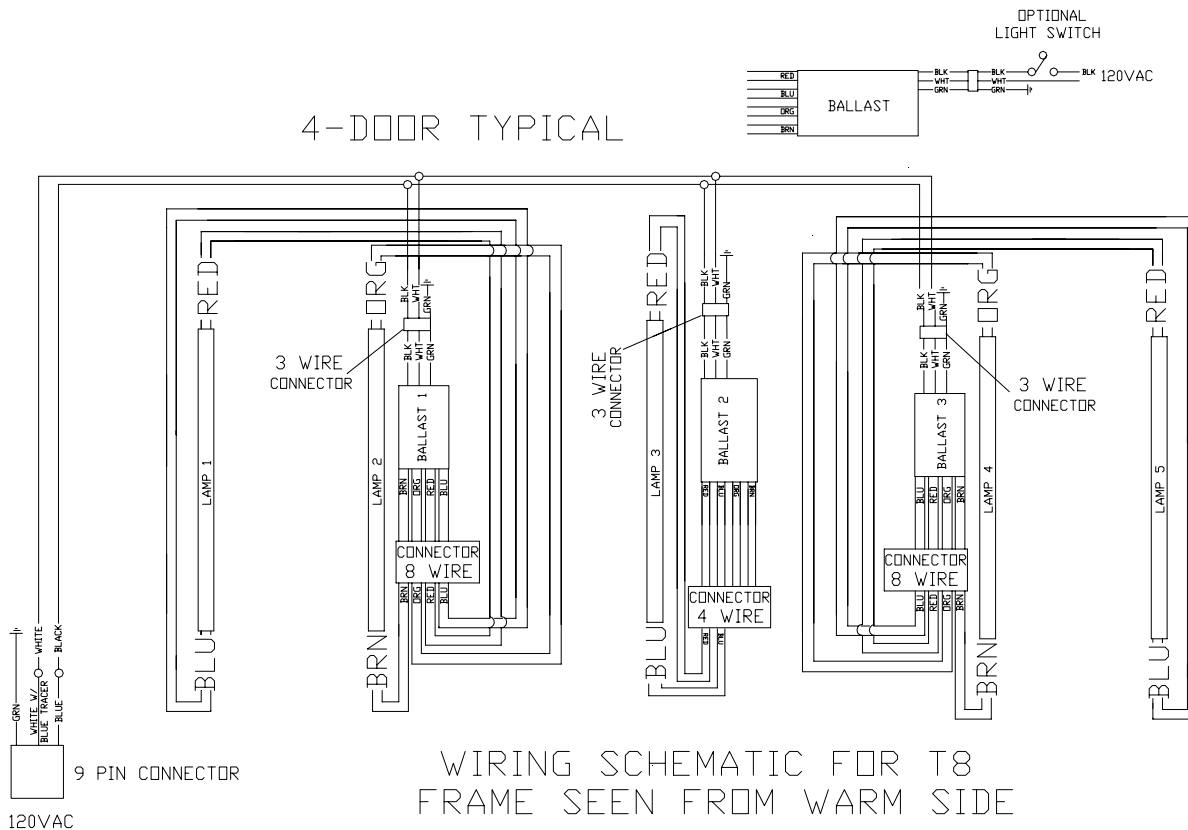

4-DOOR TYPICAL

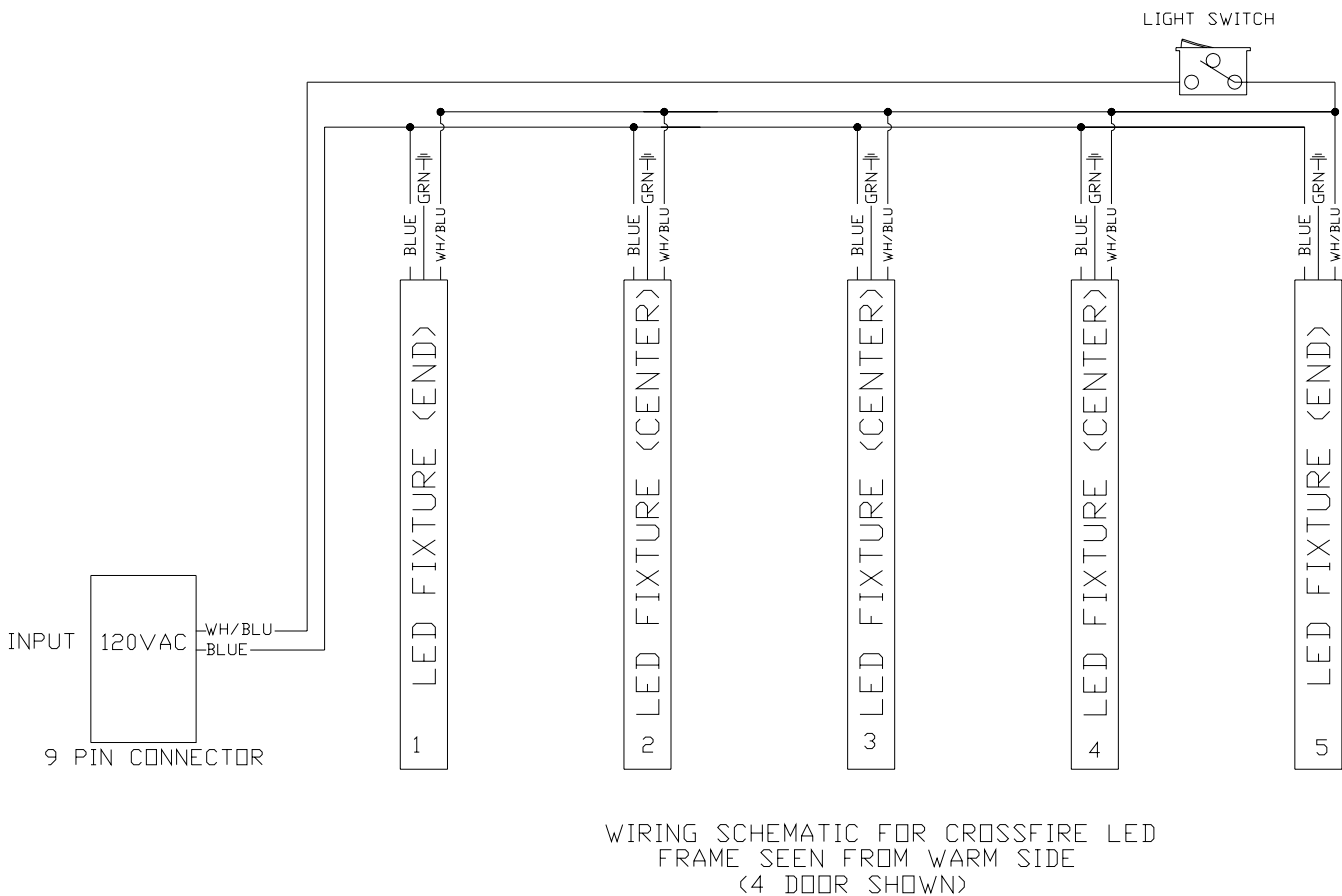
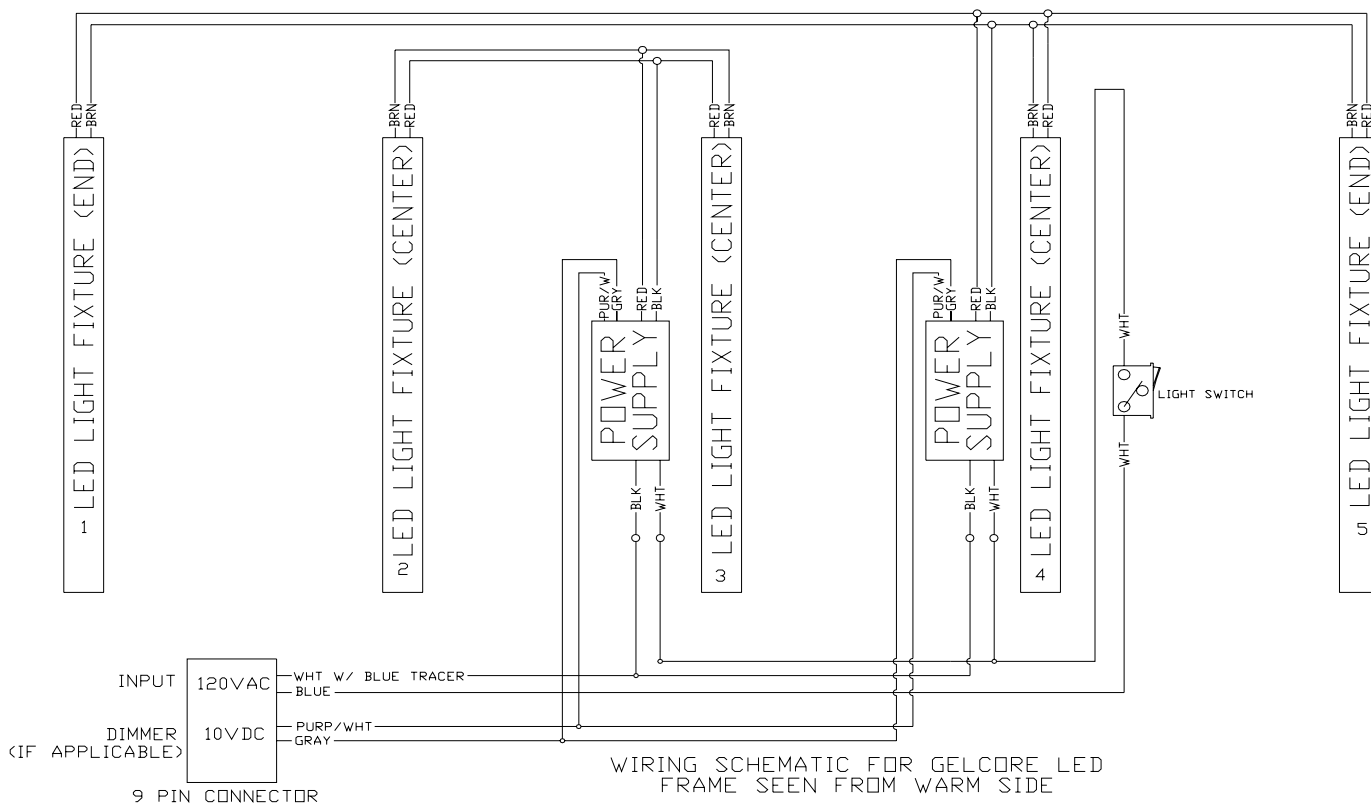

Note: The power supply for Crossfire LED lighting is built into the LED light fixture.

Exploded view – Quik Load Door

1. Corner Block
2. Door Rail
3. Heater Wire
4. Insulated Glass Unit
5. Plastic Back Molding
6. Hinge Pin
7. Cable Bushing
8. Torque Rod Assembly
9. Access Cover
10. Handle
11. Hold Open
12. Spacer
13. Screw
14. Backer Plate
15. Shoulder Bolt
16. Gasket

Note: For specific part numbers, provide serial plate information.

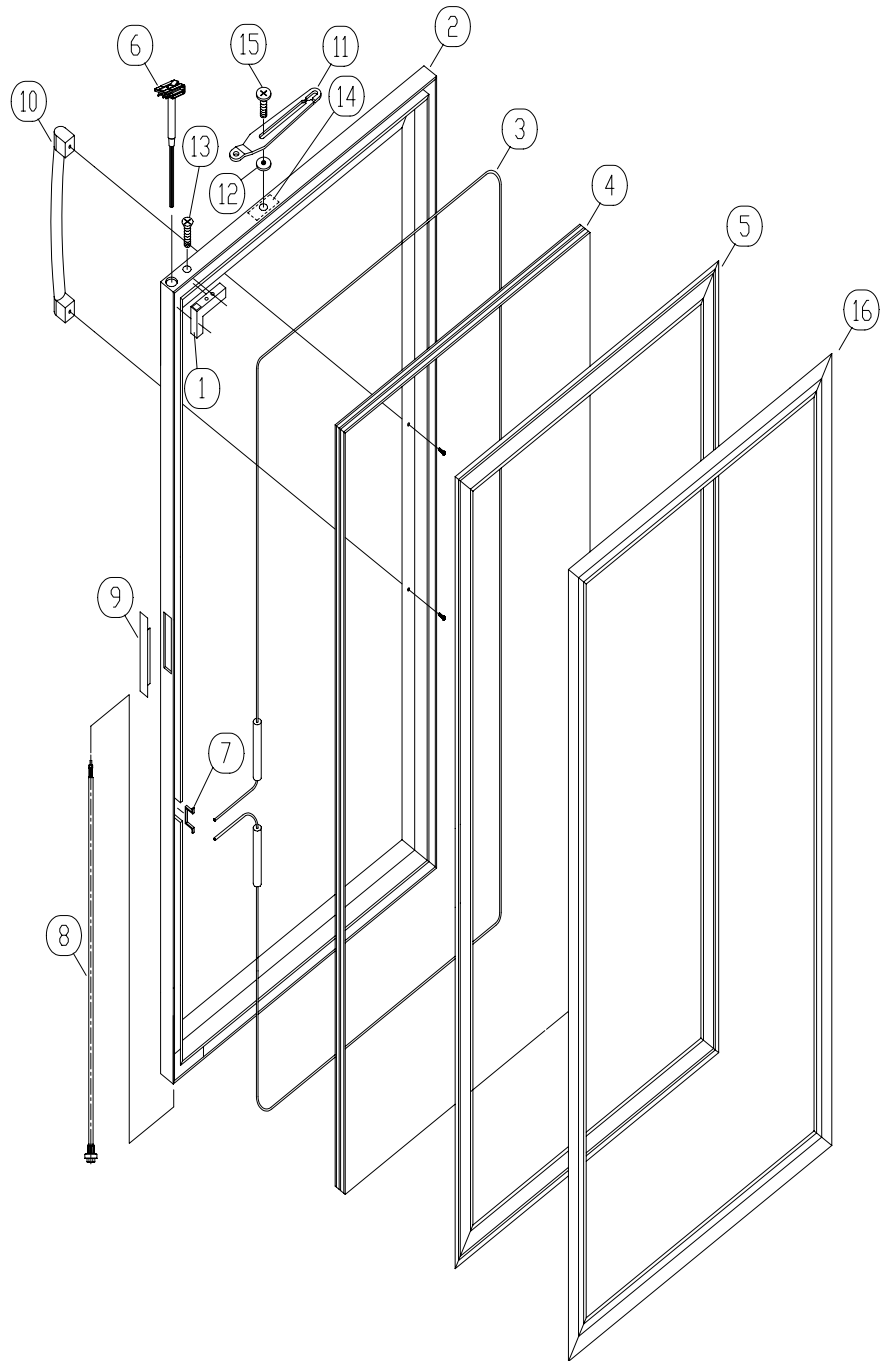

Exploded view – T8 frame

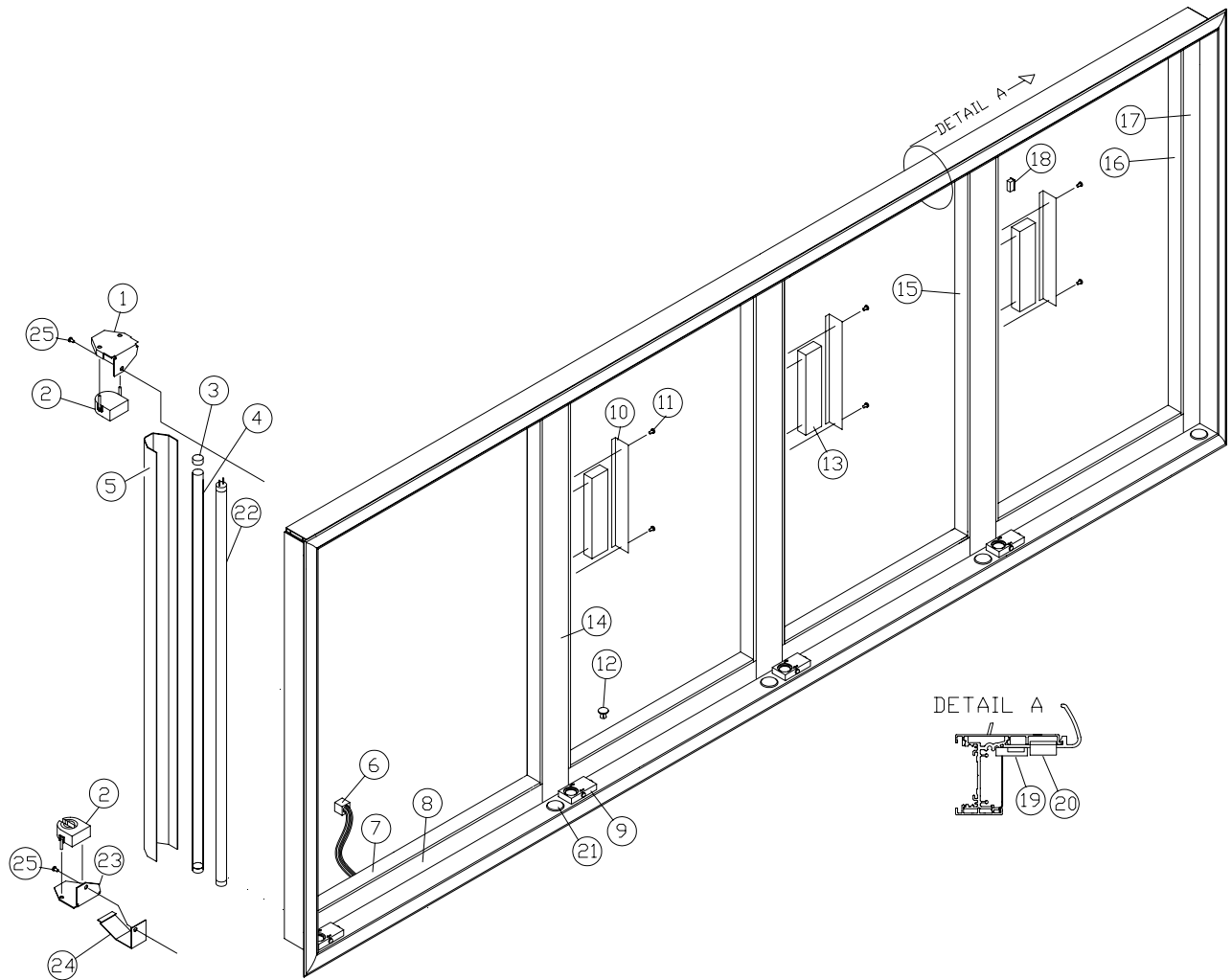

- 1 Top lamp bracket
- 2 Lamp socket
- 3 Tube guard end cap
- 4 Tube guard
- 5 Lens
- 6 9 pin electrical connector
- 7 Width vinyl
- 8 Width contact plate
- 9 Quik Load torque adjuster
- 10 Ballast cover plate
- 11 Cover Plate Screw
- 12 Mounting hole plug
- 13 Ballast
- 14 Mullion contact plate
- 15 Mullion side vinyl
- 16 Vertical vinyl
- 17 Vertical contact plate
- 18 Light switch
- 19 Receptacle (NTH & LT only)
- 20 Gib
- 21 Hole plug (torque adjuster)
- 22 Lamp
- 23 Bottom lamp bracket
- 24 Lens spring clip
- 25 Lamp bracket mounting screw

Note: For specific part numbers, provide serial plate information.

Exploded view – Gelcore LED frame

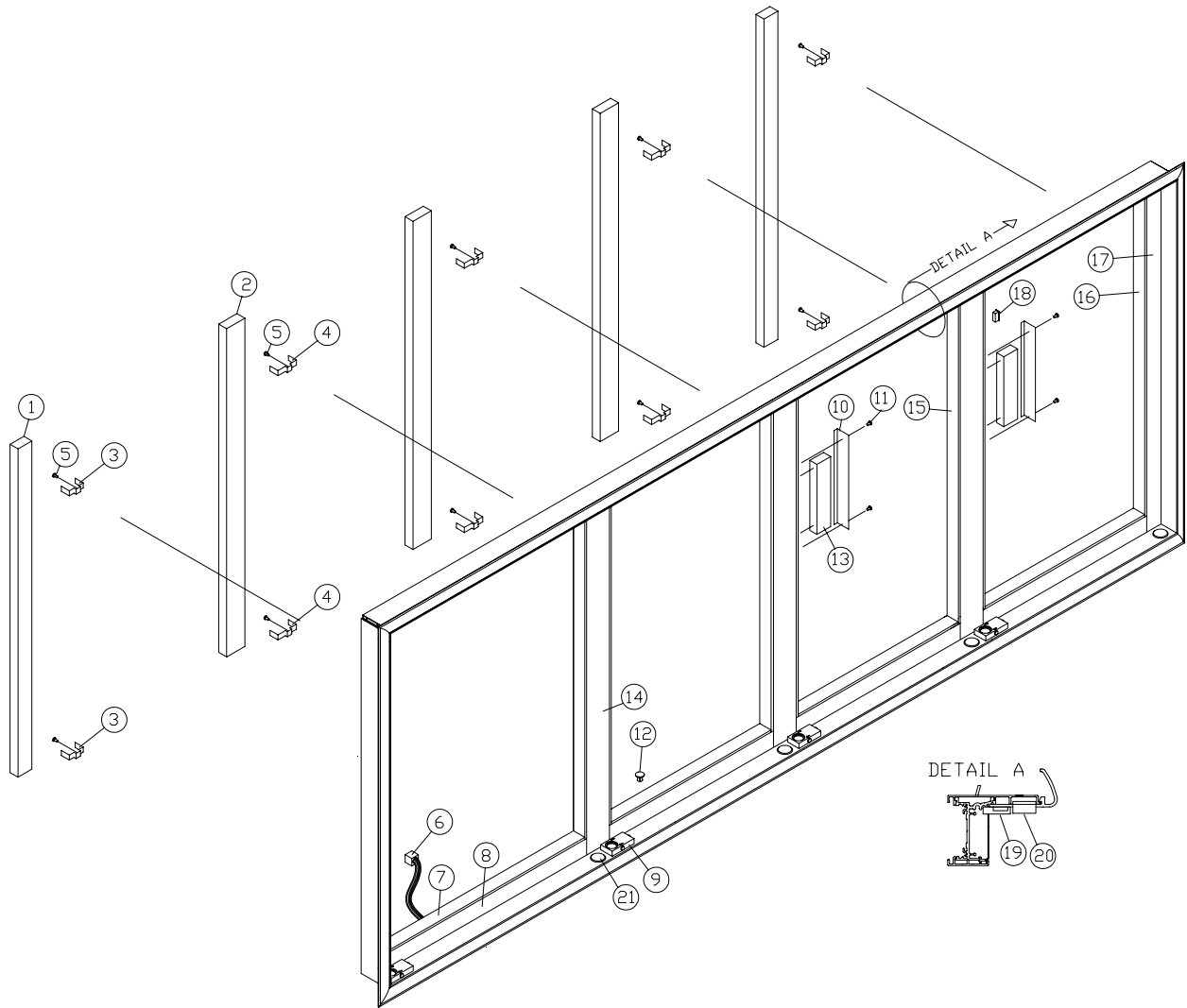

- 1 End LED light fixture
- 2 Mullion LED light fixture
- 3 End LED light bracket
- 4 Mullion LED light bracket
- 5 Lamp bracket mounting screw
- 6 9 pin electrical connector
- 7 Width vinyl
- 8 Width contact plate
- 9 Quik Load torque adjuster
- 10 Power supply cover plate
- 11 Cover Plate Screw
- 12 Mounting hole plug
- 13 Power supply
- 14 Mullion contact plate

- 15 Mullion side vinyl
- 16 Vertical vinyl
- 17 Vertical contact plate
- 18 Light switch
- 19 Receptacle (NTH & LT only)
- 20 Gib
- 21 Hole plug (torque adjuster)

Note: For specific part numbers, provide serial plate information.

Exploded view – Crossfire LED

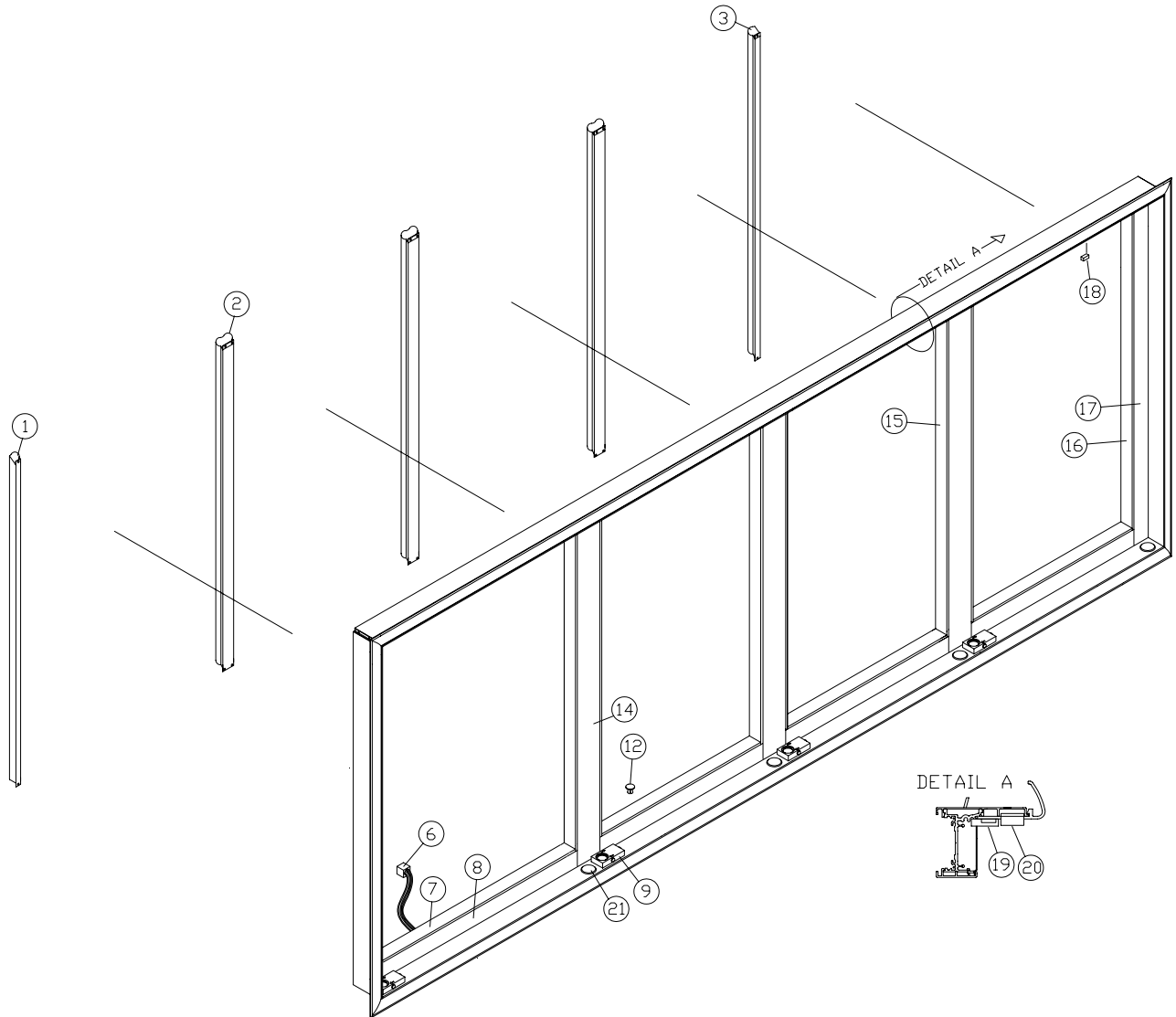

- 1 Left LED light fixture
- 2 Mullion LED light fixture
- 3 Right LED light bracket
- 4 -
- 5 -
- 6 9 pin electrical connector
- 7 Width vinyl
- 8 Width contact plate
- 9 Quik Load torque adjuster
- 10 -
- 11 -
- 12 Mounting hole plug
- 13 -

- 14 Mullion contact plate
- 15 Mullion side vinyl
- 16 Vertical vinyl
- 17 Vertical contact plate
- 18 Light switch
- 19 Receptacle (NTH & LT only)
- 20 Gib
- 21 Hole plug (torque adjuster)

Note: For specific part numbers, provide serial plate information.

Care & Cleaning: Gemtron Doors and Frames

Cleaning—Inside

The interiors of doors and frames should be cleaned at least once a year. Unplug the doors and frames before cleaning. If this is not practical, wring excess moisture out of sponge or cloth when cleaning around switches, lights, and controls.

Use a warm water and baking soda solution—about a tablespoon (15 ml) of baking soda to a quart (1 L) of water. This both cleans and neutralizes odors. Rinse thoroughly with water and wipe dry. When cleaning other parts of the doors and frames—including gaskets and all plastic parts—use the same solution. After cleaning door gaskets, apply a thin layer of petroleum jelly to the door gaskets at the hinge side. This helps to keep the gaskets from sticking and bending out of shape. Do not use cleansing powders or other abrasive cleaners.

Cleaning—Outside

The exteriors of doors and frames can be cleaned with a cloth dampened with a solution of mild liquid dishwashing detergent and water. Dry with a soft cloth.

Use a household wax, such as Pledge brand or Jubilee brand, to coat the handles. Soil will then easily wash off with dish detergent and water or a non-abrasive all-purpose cleaner. Glass can be cleaned with off-the-shelf glass cleaner.

Do not use scouring pads, powdered cleansers, bleach, or cleaners containing bleach because these products can scratch and weaken the finish.

Gemtron ANTI-FOG/ANTI-FROST COATED GLASS RECOMMENDED CLEANING

Gemtron's Anti-Fog/Anti-Frost coating can sometimes become contaminated which degrades the Anti-Fog performance. The result can be splotchy areas of fog or frost. Even certain cleaners can leave a residue that blocks the Anti-Fog performance. The solution is to clean the undesirable residue off of the coating. The best products for cleaning the Anti-Fog coating are degreasers. The preferred degreasing cleaner is "Greased Lightning".

Recommended cleaning procedures for Gemtron Anti-Fog/Anti-Frost coating:

Don'ts

- Do not use sealants, gaskets, or other materials containing silicone that can contaminate the coating.
- Do not use tape, glue, stickers, attachments, or magic markers on the anti-fog coating.
- Do not use razor blades or any other mechanical device to remove foreign residue or objects directly from the coated glass.
- Do not use abrasive cleaners or materials on the coated glass. Examples of these cleaners or materials include Ajax, Brillo, Comet, Scotch Brite, Steel Wool, and Soft Scrub.
- Do not use cleaners or materials on the coated glass that hinder the anti-fog performance by leaving residue or damaging the surface. Examples of these cleaners include: Armor All, Tilex, Bleach, Windex No-Drip, Windex Wipes, Pledge, or any product containing silicone oils or waxes.

Do's

- Recommended cleaners include: Greased Lightning, Formula 409 Grease & Grime, Formula 409 Grease & Surface, Fantastic, Mr. Clean, Windex Vinegar, Windex Original, Now, or Mean Green (degreasing cleaners). Isopropyl alcohol and acetone are also good degreasing cleaners. If you have any question about the use of a particular cleaner, please contact AFG.
- Recommended cleaning is with a soft dry or slightly damp towel, or with one of the degreasing cleaners listed above.

**Gemtron Food Display • 2840 Nebo Road, Madisonville, KY 42431 • Toll-Free: 800.326.2717 • Phone:
270.821.2864 • Fax: 270.326.3624
E-mail: info@gemtrondoors.com • www.gemtrondoors.com**