



Highlight Merchandiser® 1RHCC30 & 1RHZC30 Hybrid™ Specs

1-Door Medium and Low Temp Hybrid™ Reach-Ins with 30" x 68" CoolView® Envision® Doors

R-404A Refrigerant

R-448A Refrigerant

Standard Package

Refrigeration Data	
Refrigerant Charge (lbs.) ¹	
Zero Zone Condensing Unit #	
Condensing Unit Crated Weight (lbs.)	
Electrical & Energy Data ^{2, 3, 4}	
MOCP (amps) ⁵	
MCA (amps) ⁶	
Daily Energy Use (kWh)	
Rejected Heat (Btuh) ⁷	
Electrical & Energy Data ^{2, 3, 4}	
MOCP (amps) ⁵	
MCA (amps) ⁶	
Daily Energy Use (kWh)	
Rejected Heat (Btuh) ⁷	

1-Door Med Temp	1-Door Low Temp
3.0	3.5
69-10042	69-10047
61	115
With Condensate Removal System	
15	15
8.2	14.6
4.0	10.9
564	1,555
Without Condensate Removal System	
15	15
6.4	12.5
3.9	10.7
549	1,526

1-Door Med Temp	1-Door Low Temp
3.0	3.5
69-9933	69-9969
61	115
With Condensate Removal System	
15	15
8.2	14.6
3.7	10.7
519	1,526
Without Condensate Removal System	
15	15
6.4	12.5
3.6	10.5
505	1,497

High Humidity Package⁸

Refrigeration Data	
Refrigerant Charge (lbs.) ¹	
Zero Zone Condensing Unit #	
Condensing Unit Crated Weight (lbs.)	
Electrical & Energy Data ^{3, 4, 9}	
MOCP (amps) ⁵	
MCA (amps) ⁶	
Daily Energy Use (kWh)	
Rejected Heat (Btuh) ⁷	
Electrical & Energy Data ^{3, 4, 9}	
MOCP (amps) ⁵	
MCA (amps) ⁶	
Daily Energy Use (kWh)	
Rejected Heat (Btuh) ⁷	

1-Door Med Temp	1-Door Low Temp
3.0	3.5
69-10042	69-10047
61	115
With Condensate Removal System	
15	20
8.4	14.6
6.3	14.7
901	2,092
Without Condensate Removal System	
15	15
6.9	12.9
6.2	14.5
887	2,063

1-Door Med Temp	1-Door Low Temp
3.0	3.5
69-9933	69-9969
61	115
With Condensate Removal System	
15	20
8.4	14.6
5.8	14.3
820	2,031
Without Condensate Removal System	
15	15
6.9	12.9
5.7	14.1
806	2,003

Physical Data

Case Calculations	
Facings (ft. ²)	
Packout (ft. ³) 24" Shelves	
Weight (lbs.) ¹⁰	

1-Door Med Temp	1-Door Low Temp
14.1	14.1
27.9	27.9
532	532

1-Door Med Temp	1-Door Low Temp
14.1	14.1
27.9	27.9
532	532

Notes:

1. Refrigerant charge includes combined condensing unit and case charges.
2. Data based on Zero Zone ChillBrite® 5 LED lighting, Zero Zone CoolView® Envision® doors, and SSC electronic fan motors. See separate remote case spec sheets for more details.
3. 115V 3-wire service; 115V-1PH-60HZ; black power, white neutral, green ground. Buck/boost transformer available for low voltage conditions.
4. Optional main service disconnect is available upon request.
5. MOCP = Maximum over-current protection.
6. MCA = Minimum current amps.
7. Adequate ventilation must be provided to dissipate rejected heat from the top of the unit for proper performance. Clearance of less than 30" above the top of the shroud to the ceiling requires special design considerations. See Zero Zone Hybrid™ Installation & Operation Manual for specific details.
8. High Humidity Package includes high-wattage anti-sweat components that prevent condensation on doors and components in ambient conditions up to 85°F and relative humidity of 70%. An anti-sweat controller is required for DOE compliance.
9. Data based on Zero Zone ChillBrite® 5 LED lighting, Zero Zone CoolView® Envision® extra heat doors, and SSC electronic fan motors.
10. Does not include weight of condensing unit. Weights include 2 end panels at 60 lbs. per pair.



Highlight Merchandiser® 1RHCC30 & 1RHZC30 Hybrid™ Specs

1-Door Medium and Low Temp Hybrid™ Reach-Ins with 30" x 68" CoolView® Envision® Doors

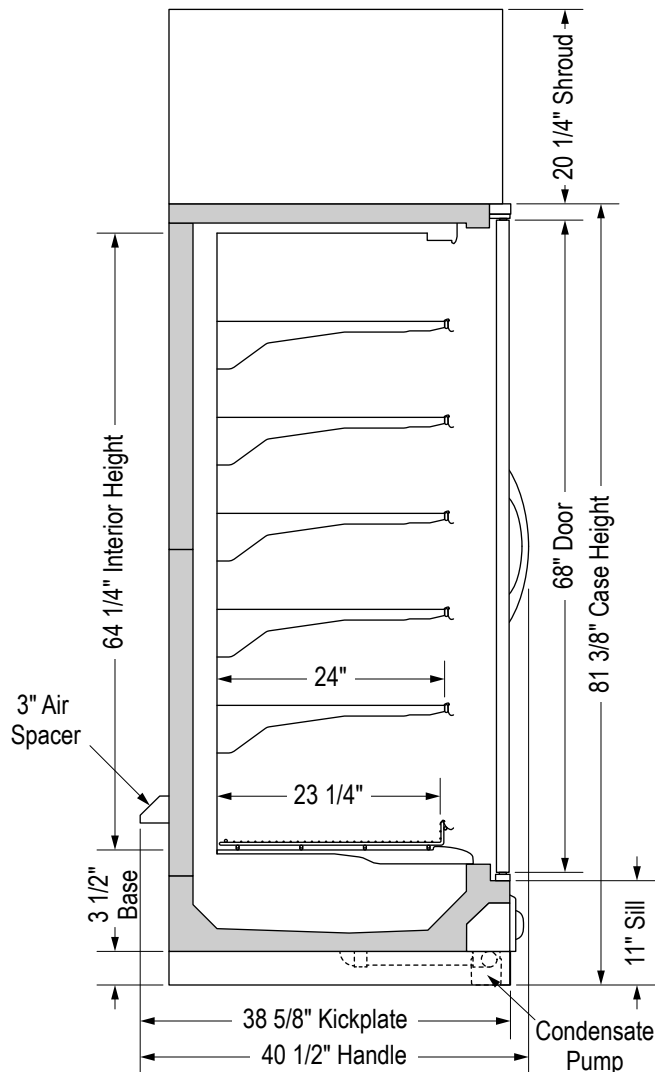
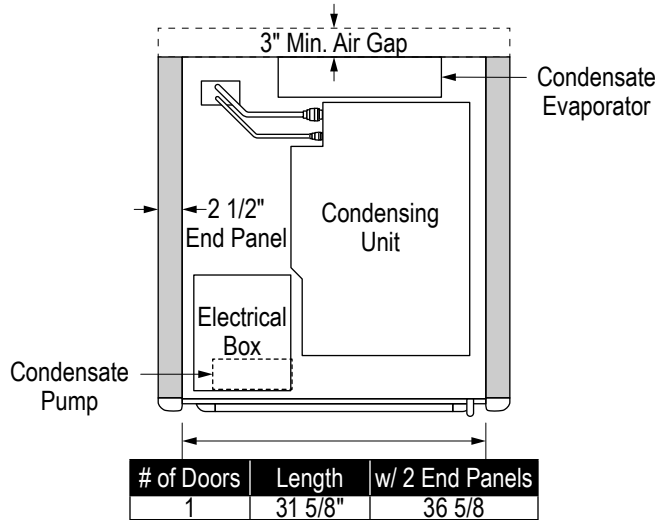

SS-83-C

Specifications are subject to change without notice. All dimensions are nominal. Case designed to operate in an ambient temperature of 75°F and relative humidity of 55% or lower. See separate remote case spec sheets for additional details.

6/16/2021



Zero Zone, Inc.
800-247-4496 • www.zero-zone.com
© 2021 Zero Zone, Inc.

