



1RVZC30 Hybrid™ Specifications

Low Temp Hybrid Reach-In with 63" Door

Note: Effective 1/1/12, all Zero Zone display cases manufactured for shipment within the U.S. meet or exceed current DOE energy requirements.

PHYSICAL DATA

	1-Door
Facings (ft. ²)	14.1
Packout (ft. ³)	25.8
Shelf Depth (in.)	22
Weight (lbs.)*	532

* Does not include weight of condensing unit. Weights include 2 end panels at 60 lbs. per pair.

ELECTRICAL DATA 115V 1PH 60HZ¹

	OptiMax Pro24 LED Lighting, Anthony ELM-HG2 Doors, SSC Fan Motors w/ Cond Evap System ³
MOCP (amps) ²	25
MCA (amps)	19.1

ENERGY DATA

Daily Energy Use (kWh)	15.4
Rejected Heat (Btuh) ³	2,192

R-404A CHARGE

R-404A Charge (lbs.) ⁴	3.5
-----------------------------------	-----

REFRIGERATION

ZZ Condensing Unit No.	69-9629
Crated Weight (lbs.)	118

Notes:

- 115V 3-wire service; 115V-1PH-60HZ; black power, white neutral, green ground. Buck/boost transformer available for low voltage conditions. Main service disconnect is not provided.
- MOCP = Maximum over-current protection.
- Adequate ventilation must be provided to dissipate rejected heat from the top of the unit for proper performance. Clearance of less than 30" above the top of the shroud to the ceiling requires special design considerations. See Zero Zone Hybrid Installation and Operation Manual for specific details.
- Refrigerant charge includes combined condensing unit and case charges.

Factory Installed Hybrid™ Features:

- Refrigeration piping with quick connect couplings and refrigerant charge.
- Pre-wired and labeled for easy connection.
- Electronic control includes: time clock, temperature and defrost control, visual and audible temperature alarm, and network communication capability.

Field Installed Hybrid™ Features:

- 20.125" tall aluminum shroud (front and sides).
- Condensing unit with quick connect threaded couplings.
- Condensate collection and removal system: collection pan, pump, float switch, condensate dissipation pan with heater element, and connecting tubing.



1RVZC30 Hybrid™ Specifications

Low Temp Hybrid Reach-In with 63" Door

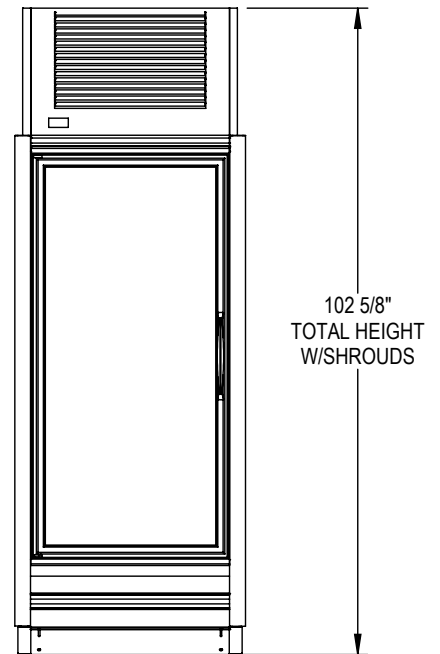
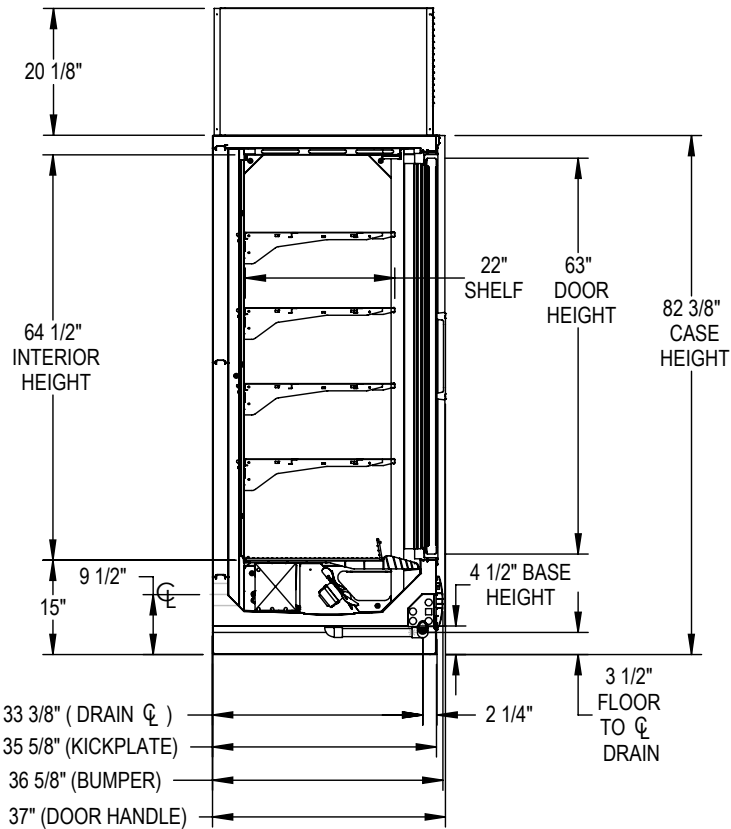
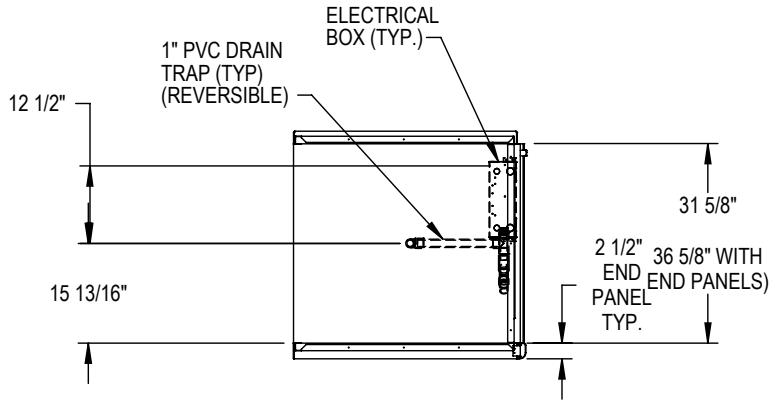

2/17/15

Specifications are subject to change without notice.
Case designed to operate in an ambient temperature of 75°F and relative humidity of 55% or lower.

EVOLUTION

Zero Zone, Inc. | 110 N Oakridge Drive | North Prairie, WI 53153-9792
Toll Free: 800-247-4496 | Fax: 262-392-6450
Zero-Zone.com

© 2015 Zero Zone, Inc.

