



ZERO ZONE

HIGHLIGHT MERCHANDISER[®]

With CoolView[®] Doors & ChillBrite[®] LED Lighting

INSTALLATION & OPERATION MANUAL





Table of Contents

- ZERO ZONE WARRANTY.....1**
 - Limited Warranty1
 - Extended Warranties1
 - Length of Extended Warranty1
 - Product Not Manufactured By The Seller1
 - Limitation and Exclusion of Warranties1
- INTRODUCTION.....2**
 - Important User Information2
 - Manufacturer.....2
 - Intended Use.....2
 - Display Case Models2
- INSTALLATION & OPERATION.....4**
 - Delivery Inspection.....4
 - Packaging4
 - Location4
 - Leveling.....4
 - Setting the Case5
 - Moving Cases5
 - Lineup Assembly.....6
 - Drain Line.....7
 - Bumper and Kickplate.....7
 - Cleaning.....8
 - Shelves9
 - Loading the Case.....9
 - Light Switch.....9
 - Case Thermometer9
 - Service.....10
 - Fan Removal.....11
 - Refrigeration11
 - Electrical12
 - Defrosting - Low Temp.....14
 - Anti-Sweat Heaters - Low Temp18
 - Anti-Sweat Heaters - Medium Temp18
 - Doors18

- ILLUSTRATIONS19**
 - Case Label Information.....19
 - Leveling.....20
 - Moving Cases26
 - RHZC / RHCC Caulking Instructions27
 - Required Sealing for NSF-Approved Installations28
 - Joining Insulated Dividers - RHZC / RHCC to RHZC / RHCC29
 - Joining Insulated Dividers - RHZC / RHCC to RVLC / RVMC30
 - Attaching Kickplate Splice - RHZC / RHCC to RVLC / RVMC31
 - Field Mounted Trap32
 - Under Case Return Air Flow34
 - Penetration Sealing.....35
 - P-trap Installation36
 - General37
 - Refrigeration Line Sizing - Low Temp38
 - Refrigeration Line Sizing - Medium Temp40
 - Electric Defrost - Low Temp41
 - Hot Gas Defrost - Low Temp.....42
 - Single Point Connection - Low Temp43
 - Master/Satellite Wiring - Low Temp44
 - Off Cycle Defrost or Satellite Wiring - Medium Temp.....45
 - Single Point Connection or Master Wiring - Medium Temp46
 - Hot Gas Defrost - Low Temp.....47
 - Electric Defrost - Low/Medium Temp48



ZERO ZONE WARRANTY

Limited Warranty

Zero Zone, Inc. (Seller) hereby warrants that any products manufactured by it and sold are warranted to be free from defects in material and workmanship, under normal use and service for its intended purpose, for a period of one (1) year from the date of original installation (not to exceed 15 months from the date of factory shipment). Zero Zone ChillBrite® LED Lighting carries a 5-year parts warranty. Zero Zone CoolView® Doors carry a 10-year glass pack parts warranty. The obligation under this warranty shall be limited to repairing or exchanging any part, or parts, FOB Factory, which is proven to the satisfaction of the Zero Zone Service Department to be defective. Zero Zone reserves the right to inspect the job site, installation, and reason for failure. This limited warranty does not cover labor, freight, or loss of food or product, including refrigerant loss. This warranty does not apply to motors, switches, controls, lamps, driers, fuses, or other parts manufactured by others and purchased by the Seller unless the manufacturer of these items warrants the same to the Seller, and then only to the extent of those manufacturer's warranty to the Seller. Any products sold on an "AS IS" basis shall not be covered by this warranty.

Extended Warranties

In addition to the standard limited warranty, for further consideration, the Seller will extend to the original purchaser prior to shipment, a limited extended warranty on the compressor only, following expiration of the standard warranty. The Seller agrees to repair or exchange, at its option, or provide reimbursement for such exchange as directed, less any credit allowed for return of the original compressor, of a compressor of like or similar design and capacity, if it is shown to the satisfaction of Zero Zone that the compressor is inoperative due to defects in factory workmanship or material under normal use and services as outlined by Zero Zone in its Installation & Operation Manuals and other instructions.

Length of Extended Warranty

Any compressor warranty may be extended for an additional four (4) years, but such extension must be purchased prior to shipment to be effective. This warranty is only for the compressor and not for any other associated parts of the refrigeration system.

Product Not Manufactured by the Seller

The written warranty, if any, provided by the manufacturer of any part of the refrigeration unit sold by Seller to Buyer, but not manufactured by Seller, is hereby assigned to the Buyer. However, Seller makes no representation or warranty regarding the existence, validity, or enforceability of any such written warranty.

Limitation and Exclusion of Warranties

THE WARRANTIES SET FORTH HEREIN ARE EXCLUSIVE AND IN LIEU OF ALL OTHER WARRANTIES AND REMEDIES WHATSOEVER, INCLUDING, BUT NOT LIMITED TO, IMPLIED WARRANTIES OF MERCHANTABILITY AND/OR FITNESS FOR A PARTICULAR PURPOSE.

INTRODUCTION

Important User Information

Copyright © 2024 Zero Zone, Inc.

All rights reserved. No part of the contents of this manual may be reproduced, copied, or transmitted in any form or by any means including graphic, electronic, or mechanical methods or photocopying, recording, or information storage and retrieval systems without the written permission of the publisher, unless it is for the purchaser's personal use.

The information in this manual is subject to change without notice and does not represent a commitment on the part of Zero Zone. Zero Zone does not assume any responsibility for any errors that may appear in this manual. In no event will Zero Zone be liable for technical or editorial omissions made herein, nor for direct, indirect, special, incidental, or consequential damages resulting from the use or defect of this manual.

The information in this document is not intended to cover all possible conditions and situations that might occur. The end user must exercise caution and common sense when installing, using, or maintaining Zero Zone products. If any questions or problems arise, call Zero Zone at 800-247-4496.

Any change to a Zero Zone product made during the installation, start-up, or at any other time must be submitted in writing to Zero Zone for approval and be approved by Zero Zone in writing prior to commission. The product warranty is voided when any unapproved change is made to a Zero Zone product.

Manufacturer

Zero Zone, Inc.
Display Case Division

110 N Oakridge Dr • North Prairie, WI 53153 • 800-247-4496 • www.zero-zone.com

Intended Use

Zero Zone products are intended to be installed and used as described in this manual and other related Zero Zone literature, specifications, drawings, and data. Always install Zero Zone products on a level surface.

The information contained in this manual pertains to Zero Zone Display Cases, which include the following:

Display Case Models

LOW TEMPERATURE DISPLAY CASES	
RHXC30	RHXC30T
RHXC30BB	RHXC30TBB

MEDIUM TEMPERATURE DISPLAY CASES	
RHCC30	RHCC30T
RHCC30BB	RHCC30TBB
RHCC24	

Zero Zone produces high quality refrigerated display cases using state-of-the-art components. The cases are built with the thickest insulation in the industry and a high efficiency evaporator coil.

Potential case features include:

- Brushless D.C. electronic fan motors
- Zero Zone ChillBrite® LED lighting
- Zero Zone CoolView® doors with heated glass and rails on low temp cases
- Zero Zone CoolView® no-energy doors on medium temp cases

INTRODUCTION

These display cases were designed and tested using the following industry standards:

- ASHRAE Standard 72-2014 — Method of Testing Commercial Refrigerators and Freezers (ANSI Approved)
- AHRI 1200 — Performance Rating of Commercial Refrigerated Display Merchandisers and Storage Cabinets (ANSI Approved)
- UL 471- Commercial Refrigerators and Freezers (ANSI Approved) (equipment certified by ETL)
- NSF 7- Commercial Refrigerators and Freezers (ANSI Approved) (equipment certified by NSF)
- DOE Compliant (all U.S. sales)

ASHRAE 72-2014 specifies the test conditions for the equipment. It includes the ambient conditions of 75°F dry bulb and 55% RH. It also specifies the door opening requirements for the performance test. Doors are opened 6 times in 1 hour for 6 seconds. The door opening test period is for 8 hours during one 24-hour performance test. As an example, a 5-door case will have 240 door openings during one 24-hour test. Consult the factory if your store exceeds these test conditions.

INSTALLATION & OPERATION

Delivery Inspection

These display cases were carefully factory-tested, inspected, and properly packed to ensure delivery in the best possible condition. The equipment should be uncrated and checked for damage immediately upon delivery. **DAMAGE MUST BE NOTED AT TIME OF DELIVERY AND ALL CLAIMS FOR DAMAGES MUST BE FILED WITH THE TRANSPORTATION COMPANY - NOT WITH Zero Zone.** The carrier will supply necessary report and claim forms.

Packaging

Each case in a lineup is labeled to identify the lineup and joint. The label uses a number and letter designation. The number indicates the lineup. The letter indicates the case joint. Case joints begin with the letter A at the left most joint in the lineup when looking at the front of the lineup. The joint for two cases has the same number-letter designation. Back-to-Back cases have a unique designation. The left most joint in the lineup when looking at the front of the case is labeled 1-A. The joint on the back of the case is 1-A1. **See Figure 1 on page 19.**

Insulated dividers are factory-installed to separate low and medium temperature cases. They are also used to join different case models. Factory-installed plexiglass dividers separate refrigeration circuits.

The first case in the lineup (with the right side labeled "A") has a packet attached to the door handle that contains the manual, special instructions for installing ordered options, and touch-up paint if the cases are custom painted. Every case in the lineup has a packet attached to the door that contains the specific information for that case. The packing slip is taped to the right-hand door of each case.

Bumpers and kickplates are shipped on top of the case. Shelves for the case are tie-wrapped and blocked into the individual cases. Other accessories like drain traps, drain pans, condensate evaporation pans, and hat channel rails are shipped in the case that require the parts.

Materials for joining cases include caulk, joining bolts, splices, and Case Joint Vertical Trim. These parts are supplied in cases that have a left-side insulated divider or no left end. The parts are bagged and taped to the coil covers. The Case Joint Vertical Trim is tied to the shelves.

Location

These cases must not be installed in the direct rays of the sun or near a source of radiant heat.

Be certain that the floor under the installation is of sufficient strength to prevent sagging. Unlevel conditions will result in reduced performance.

Wall cases (cases set with a back to a wall) and cases set back-to-back, should be positioned to allow a minimum 3-4" space behind the back of the unit(s). This will allow necessary air to circulate behind the display case(s). Higher humidity stores with minimal air circulation require a 4" gap.

Recommended minimum 2" gap between cases on end-to-end installations.

Leveling

Cases must be installed perfectly level to allow efficient operation of the refrigeration coils and complete drainage of defrost water. Since a level area is seldom available, the following steps are recommended to ensure a level installation.

1. Measure off and mark on floor the exact dimensions of the case lineup. **See Figure 2A on page 20.** (Check blueprints.)
2. Snap a chalk line at the locations for the front and back positions of the bases.
3. Mark locations of all joints (front and back).
4. Using a laser or transit, find the highest point along both base rail position lines. Using the high point as a reference, mark the difference directly on the floor to each base, front and back. **See Figure 2B on page 20.**

INSTALLATION & OPERATION

5. If you plan on using optional hat channel rails to raise the case height, place them under each pair of bases. The 3 and 4-door hat channel rails will be angled slightly to support the front and rear bases. **See Figure 4 on page 22** and **See Figure 6I on page 25**.
6. Place the required number of shims under each base or optional hat channel rails at each joint (front and back) to equal the highest point.
7. The RHZC30 and RHCC30, 2 through 5-door cases, have segmented bases mounted at the ends and under the center section of the case. The RHZC30 and RHCC30 1-door and RHZC30BB and RHCC30BB have full bases that run front to back and are located at the ends and under the center sections of the case.
8. Tape all shims in place. **See Figure 2C on page 20**. Ensure the correct orientation of shims under the base or channel. **See Figure 5 on page 22**.
9. Place additional support shims under all other bases or hat channel rails. **See Figure 6 on page 23**.
10. Use a carpenter's level to check installation as you go. The case should be level from front to back and side to side. Install the case at the highest point first, if part of a lineup. Check the level on the face of the glass doors and sides of the mullions. Do not use the ceiling to check level.
11. If you've purchased seismic restraints, specific instructions for attaching those restraints are included in your document package. These instructions should be read and followed before the lineup is assembled.

Setting the Case

Position hat channel rails with tape up.

For 3 and 4-door cases, the center hat channel rail needs to be angled to rest on front and back base. Do not locate under drain hub. For 5-door cases, there are 4 hat channel rails. **See Figure 3 on page 21**.

In most instances, cases will require leveling by using shims. Refer to the Leveling Section.

Moving Cases

The Back-to-Back (BB) cases are shipped with wood planks that allow the use of pipe rollers. These wood planks should be removed after the case is moved to its final location. **See Figure 7 on page 26**.

The RHZC, RHCC, and BB cases have steel protective support plates under the ends (not under insulated dividers). These are designed to protect the end from Johnson Bar damage.

Use the following methods to move the cases:

MODEL	FORK LIFT FROM ENDS	JOHNSON BAR	FURNITURE DOLLY	PIPE ROLLERS	SAFE (CASE) JACKS
RHZC30	✓	✓	✓		✓
RHZC30BB	✓	✓	✓	✓	✓
1RHZC30	✓*	✓	✓	✓	✓
RHCC30	✓	✓	✓		✓
RHCC30BB	✓	✓	✓	✓	✓
1RHCC30	✓*	✓	✓	✓	✓

* Fork lift from rear

Care should be taken when moving the cases. The doors should be secured so they cannot open while the case is moved.

INSTALLATION & OPERATION

Only experienced, certified fork truck drivers should use fork trucks to move the cases. The case should only be lifted off the floor as high as necessary for transport. The fork truck should be driven slowly to avoid any abrupt motions or bumps.

The following forklift dimensions must be maintained to avoid damaging the case when it is lifted:

2-DOOR CASES

Forks must extend from 26" to no more than 28" under the case.

3-DOOR CASES

Use 48" long forks!

Forks must extend from 39" to no more than 43" under the case.

4 & 5-DOOR CASES

Use 48" long forks!

Fork blades wider than 4" will not fit in the bases.

Spacer blocks are factory-installed in the end bases of 4 and 5-door cases that use 4 1/2" bases. **See Figure 8 on page 26.** These blocks limit the case's forward tilt while it is being lifted and must be used when lifting 4 or 5-door cases with 4 1/2" bases.

For low shipping height applications, Zero Zone has optional, expandable bases. As shipped, the base is 1 3/4" tall. It is attached with spacers that allow the base to slide away from the bottom of the case to create a gap that allows the use of a 1 1/2" thick fork truck blade. **See Figure 9 on page 26.**

Lineup Assembly

Zero Zone display cases have been engineered for continuous display. This means that any number of cases can be joined together to create a display of a desired length. The bottom of the end panel is protected with a removable steel plate.

The cases will be ready for assembly after removal of the packaging material.

Case caulking instructions are shipped with every case, explaining the proper procedure for joining cases. **See Figure 10 on page 27.** Instructions on joining a Highlight™ case to a Crystal Merchandiser™ case are detailed as well. **See Figure 14 on page 30** and **See Figure 15 on page 31.**

FIELD-INSTALLED CAULK SEALANT APPLICATION NOTES:

Butyl sealant is used to join cases and silicone or NSF approved sealant is used for NSF compliance. Sealants should not contact one another as this may affect adhesion or color of each.

Remove all shipping blocks applied to inside of base ends before joining cases.

Remove end protection plate located below end on outside of case.

FAILURE TO FOLLOW THE INTENT OF CASE JOINING INSTRUCTIONS WITH SEALANTS WILL CAUSE FROST INSIDE THE CASE.

For NSF case installation compliance, the interior case seams need to be sealed using NSF approved caulk (not supplied). **See Figure 11 on page 28.**

INSTALLATION & OPERATION

After setting the first case, the next case is slid into position and bolted to the first case using four 3/8" bolts that are provided. Begin tightening the bolts at the top rear, working down the back of the case and up the front, making sure that the front seams are flush. Do not attempt to pull cases together using the joining bolts.

Alignment holes are located in the lower steel end frames. These are located 7" in from the joining holes.

Once the cases have been caulked and slid together, start the joining bolts, but do not tighten them. Begin tightening the bolts at the top rear, working down the back of the case and up the front, making sure that the front seams are flush. Cases are not designed to be pulled together using the joining bolts. Please note that when bolting the cases together, there is a welded nut in the rear center of the left mullion of the right-hand case. Therefore, it is not necessary to remove the rear ductwork of the right-hand case. Place the case joint vertical trim over the vertical raceway and screw into place.

Two different model cases or two different temperature cases are connected using an insulated divider. Typically the divider is factory-assembled to one of the cases. Two styles of divider are provided. The first style has a panel on each side with nut inserts in the panels. Each side is bolted to the end frame. The second style divider uses a thru-bolt design. The divider is attached to one of the cases using short bolts. When the case is installed, the short bolts are removed and long bolts are reinstalled to bolt both cases together. **See Figure 13 on page 29.** Do not attempt to pull cases together using the joining bolts.

Drain Line

The drain is located at the center of the case in the floor pan. The drain can be reached by removing the center coil covers and then removing a fan motor. The 1" PVC drain outlet is located at the center front of the case behind the kickplate.

Install the tee to the outlet pipe and a drain trap to the tee. Plug the open end of the tee using the clean-out plug supplied with the drain trap kit. The drain line must be pitched away from the case. The tee, drain trap, and plug are supplied with the case. We supply a trap support that is fieldmounted to the case. **See Figure 16 on page 32.** The drain trap must be level. The drain trap should be primed with water after installation. The drain line must be pitched away from the case enough to ensure proper drainage. Consult your local codes for minimum requirements.

Bumper and Kickplate

A Zero Zone bumper is standard on all case models and should be installed at the bottom front of the case. Various bumper styles are available. **See Figure 17 on page 33.** The kickplate assembly is adjustable to compensate for uneven floors. The bumper end cap is factory-installed on bumpers for cases with end panels that do not include Euro trim.

STEP 1: INSTALLING END KICKPLATE

The end kickplate attaches to the small black bracket attached to each side of the case with an end. The kickplate can be adjusted vertically to match the height of the floor below it. **See Figure 18 on page 33.**

1. Attach a Tinnerman clip to the side bumper support.
2. Place the side kickplate against the Tinnerman clip on the side bracket.
3. Install the black 3/4" screw through the side kickplate and into the Tinnerman clip. A scratch-awl or similar tool can be used to line up the holes.
4. The front of the side kickplate is located behind the front kickplate and attached with screws to the front kickplate.

STEP 2: INSTALLING BUMPER AND FRONT KICKPLATE

The front kickplate and bumper attaches using 1 1/2" screws attached to brackets located on the front of the case. The kickplate can be adjusted up and down to fit the height of the floor below it.

INSTALLATION & OPERATION

1. Starting from the left end of the lineup, attach a Tinnerman clip to each bumper support bracket. Locate them over the hole for the bumper.
2. Attach the kickplate splice to the right side of the kickplate using the 3/4" screw in the lower hole.
3. Lean the kickplate against the bumper support bracket.
4. Hang the bumper on the case. The kickplate should be located behind the bumper assembly.
5. Install the black 1 1/2" screw through the bumper, kickplate, kickplate splice, and into the Tinnerman clip. A scratch-awl or similar tool can be used to line up the holes.
6. Follow these steps to install the next bumper in the lineup. A bumper splice (provided) should be installed between the two cases. Center the splice and adjust the height so the decorative tape (if applicable) lines up. Using self-tapping screws (provided), attach the upper portion of the splice using the predrilled holes in the splice. Then with two more screws, attach the lower half.

UNDER CASE RETURN AIR FLOW ASSEMBLY INSTRUCTIONS

To assemble the bumper for under case return air flow (if requested), a spacer (provided) must be inserted between the bumper and kickplate. **See Figure 19 on page 34.** The spacer is held in place with the standard black assembly screw used to attach the bumper. One 3/8" spacer is required at each screw location (2 spacers on a 2-door, 3 spacers on a 3-door, etc.).

1. To ease installation, hook the bumper to the case and position the kickplate. Then pull the bottom edge of the bumper forward, hold the spacer in place, and then insert the assembly screw through the bumper, spacer, kickplate, bumper bracket, and into the Tinnerman clip.
2. With the spacers in place, air will be allowed to flow between the bumper and kickplate and then underneath the case. The target airflow rate under the case design is 50 cfm/door.

Note: An optional louvered kickplate is available. (Provides 150 cfm/door.)

Cleaning

The case and doors are cleaned prior to shipping. However, the case should be thoroughly cleaned before start-up and routinely thereafter to maintain a clean appearance. Use mild detergent and warm water (never an abrasive cleaner) to wipe out the inside of the case. Wash down all glass doors with glass cleaner. Do not wash down the fan motors. Do not use any products containing silicon on anti-fog glass coatings. Clean interior glass reduces fogging and increases visibility. The case will remain bright and sparkling with just a few minutes of cleaning each week. Internal components can be cleaned after removal of access panels. The case drain should be regularly cleared of debris and price tags.

Coils may be cleaned with a garden hose or pails of water. Cases that use pump, drain pans and condensate evaporators should be cleaned with a minimum amount of water. The drain should be blocked and the water removed with a shop vacuum.

Do not use high-pressure water or steam to clean the interior.

UNDER CASE FLOOR CLEANING (NSF)

The floor underneath your Zero Zone display case can be cleaned by following a few simple steps:

1. Remove the fasteners that hold the bottom kick plate to the display case. The fasteners are accessed from the front of the unit.
2. With the kick plates removed, remove paper and other debris (typically price tags or receipts) from the floor.
3. Vacuum under the case to remove any dust build-up that may be present.
4. Using an approved cleaner and warm water, mop underneath the unit.
5. When finished mopping, squeegee any remaining water underneath the unit to the floor drains to speed the drying process. Replace the kick plates when the floor has dried.

INSTALLATION & OPERATION

GLASS SURFACES

Cleaning interior glass reduces fogging and increases visibility. Wipe down glass or plexiglass mirrors or ends with a glass cleaner. Do not use any products containing silicone.

Shelf Location

- The shelves are adjustable in 1" increments on cantilever shelf cases and may be located in any position for best display advantage.
- Be sure brackets are completely seated.
- Wire shelf brackets are stamped with "R" for Right and "L" for left to aid installation.

Shelves

Zero Zone manufactures many different styles of shelves, baskets, and product stops. The fully assembled shelves are installed in cases prior to shipping. The bottom wire racks and baskets are placed on the shelves for shipping. Solid shelves have three parts: a solid center section and two snap-in brackets. Some of the baskets may be reversed and used as a typical shelf.

Solid shelves can be disassembled for cleaning. A screwdriver can be used to spread the snap open to remove the brackets from the center section.

Loading the Case

The case may be loaded with product after it has been operated for at least 24 hours with correct case temperature and proper control operation. While loading the shelves, leave a minimum of 1" air space between the top of the product and the shelf above it so the customer can remove the product. The air space allows an air curtain on top of the product. Product should not extend beyond the front of the shelves or block the return air grill. The shelf loads are as follows:

ITEM	SHELF DESCRIPTION	MAXIMUM LOAD PER SHELF
1	22" and 24" deep	250 lbs.
2	4-Position Brackets	
	At 0°	250 lbs.
	At 5°	250 lbs.
	At 10°	150 lbs.
	At 15°	100 lbs.
3	Heavy Duty	500 lbs.

Heavy duty shelves are available and are labeled as such.

Light Switch

The light switch is located on the ceiling on the right-hand side of the display case.

Case Thermometer

The cases are shipped with 2 thermometers. The first thermometer is factory-mounted in the discharge air stream. The second thermometer, required by NSF, is shipped loose and should be installed in the warmest product location. Specific instructions are included.

INSTALLATION & OPERATION

Service

UNDER CASE ACCESS

The bumper and kickplate must be removed to gain access to the drain clean out and electrical connections. Disassemble the bumper and kickplate by removing the 2 or 3 metal screws located in the kick rail. The bumper assembly can be lifted up and removed from the case. The kickplate can be removed, exposing the drain and electric enclosure cover. An optional top electrical box is available for easier installation and accessibility.

EVAPORATOR

The evaporator coil, located at the rear bottom of the case, is factory-assembled with distributor, expansion valve, and other refrigeration components. To inspect the coil, remove the center or left of center coil cover. A small inspection window is located at the rear of the case. To inspect the entire coil, remove the remaining coil covers and raise the metal evaporator cover.

EXPANSION VALVE

Unless otherwise specified, a superheat, externally-adjustable, equalized thermostatic expansion valve with pressure limiting charge (low temp only) is mounted to the evaporator coil. The valve is not preset. Adjust the superheat setting for maximum coil effectiveness. Typical superheat settings are between 6°F and 10°F. Close coupled systems should use the higher superheat setting to minimize the chance of liquid flood back. To adjust the expansion valve, remove the right end coil cover. Remove the cap from the bottom of the valve. When looking at the valve stem end, turn the valve stem counterclockwise to decrease superheat. Turn the valve stem clockwise to increase superheat. Measure the suction line temperature at the expansion valve sensing bulb and compare it to the suction temperature corresponding to the saturated pressure. Make sure that line pressure drop is taken into account.

Turn the valve stem only 1/4 turn at a time and allow sufficient time (20 to 30 minutes) for the valve to settle before making any further adjustments. Replace the valve stem cap after the valve superheat has been adjusted. **BE CERTAIN THE VALVE STEM CAP IS WIPED DRY FIRST.**

! **CAUTION!** DISCONNECT POWER TO THE CASE BEFORE SERVICING ELECTRICAL COMPONENTS TO AVOID PERSONAL INJURY AND DAMAGE TO THE UNIT.

EVAPORATOR FANS

Air is circulated throughout the case with 115 volt low temperature fan motors. These motors must be operating at all times, except during defrost in low temp cases. Fan motors should be replaced with motors having the same characteristics including type, physical size, lubricant temperature range, wattage, and RPM. Fan blades should be replaced with factory original equipment part.

CONDENSATE EVAPORATION SYSTEM

Zero Zone remote cases can be equipped with an automatic condensate evaporation system. The system uses a pump and drain pan located behind the kickplate and a condensate evaporator pan mounted on the top of the case.

Condensate water and any liquid spilled in the case drains out into the drain pan. The pump is equipped with a float that turns the pump on when there is a sufficient liquid level. Liquid is pumped through a plastic hose through a check valve and into the condensate evaporation pan. The evaporation pan is equipped with a heater and a float switch to turn on when the heater is submerged in liquid. When the heater is energized, the pan will be extremely hot and should not be touched. The pump and condensate pan should be cleaned regularly. Any spilled product should be cleaned to prevent odors.

INSTALLATION & OPERATION

AIR CURTAIN VELOCITY

Air curtain velocity is affected by stocking levels, coil frost loads, temperature, and fan condition. Air velocity should be measured at the back edge of the discharge air honeycomb, at the center of the middle door in the case (other doors have slightly lower velocity). A typical low temp velocity reading is 400 to 500 feet per minute in a fully-packed low temp case, after the case has defrosted and pulled down to operating temperature. Air curtain velocity in a partially-packed display case is significantly lower because more air exits the back wall duct holes. In fully stocked medium temp cases, the velocity should be 300 to 400 feet per minute after the case has defrosted and pulled down to temperature.

Note: Indicated velocity can vary considerably from one velometer to another.

FAN REMOVAL

1. Turn off power to fans. Remove coil cover.
2. Unplug fan from fan power supply plug located on the front face of the fan housing.
3. Remove the fan blade nut and fan blade.
4. Remove the two mounting bolts and remove the fan assembly from the fan housing.
5. Remove the three fan motor mounting screws from the back of the fan motor.
6. Reverse steps 1 - 5 to install.

LED POWER SUPPLIES AND DRIVERS

LED Drivers for the Highlight™ cases are located behind the kickplate in the electrical enclosure.

Refrigeration

Unless otherwise specified, the liquid and suction connections are made inside the case under the removeable evaporator fan/coil return air grill bottom. Refrigerant piping may enter the case through the front left bottom, the left rear bottom, or the left rear top of case. The copper pipe should not touch or rub on the edges of the sheet metal. After connections have been made, the refrigeration access hole in the case must be sealed completely with an aerosol-dispensed urethane insulation or equivalent (e.g. GREAT STUFF™). Penetrations made in sheet metal baffles should also be sealed. **See Figure 20 on page 35.**

REFRIGERANT PIPING

Correct refrigeration line sizing and installation is essential for proper system operation. **See Figure 24 on page 38, See Figure 25 on page 39, and See Figure 26 on page 40** for Highlight™ cases. Contact the factory for line sizing for the Highlight™ cases. A P-trap must be installed at the bottom of all vertical suction risers. **See Figure 21 on page 36.** Various risers are available as a factory-installed option. The compressor should be installed as close as possible to the cases to reduce pressure drop. Install a shallow trap at the bottom of the riser.

When two or more case sections are connected to one compressor, the main liquid and suction line for the group should be run through the cases and be brought out through the refrigeration outlet of one case only. The factory recommends one riser per circuit/system for hot gas defrost when using top back refrigeration exit. Circuit risers are available as a factory-installed option. On 30" wide door cases with suction lines over 1 3/8" diameter, a P-trap made with 45° elbows is required. A piping chase in front of the fan shroud allows the refrigerant lines to be run through the right or left end frame.

Piping should not be placed near the electric defrost heaters. The defrost heaters on the 30" door cases will grow one inch to the left of the coil when they reach operating temperature.

INSTALLATION & OPERATION

The best location for the liquid line drier is inside the case compartment. However, it may be installed near the compressor for easy maintenance. Install moisture indicating sight glass at the outlet end of the drier.

A low pressure or temperature control can be used to control case temperature. The control should be selected with adequate contact capacity for the switching load. In rack systems, an evaporator pressure-regulating valve may be used to control the evaporating temperature.

The settings are approximate due to variations in gauge accuracy, differences in compressor efficiency, line pressure drop, and superheat settings. **See Figure 22 on page 37.** Before making adjustments for store or stocking conditions, make sure the superheat is set. Close coupled systems typically run at the higher end of this range to avoid flood back.

TEMPERATURE CONTROL ADJUSTMENT

When factory-installed, the temperature control is located toward the right end of the case in the electrical enclosure. The sensing bulb is located under the coil cover inside the fan shroud. It can be wired in series with the low-pressure (L.P.) control. It can also be used in a pump down system by wiring it in series with the liquid line solenoid valve. **See Figure 23 on page 37** for a thermostat.

Discharge air temperature probes for electronic case controllers may be installed in many different customer-specified locations including, but not limited to, honeycomb, ceiling pocket cover, rear wall, and return air.

LEAK-CHECK/EVACUATION/CHARGING

After all of the refrigeration piping and system components have been assembled, the entire system must be pressurized and checked for leaks.

When the system is leak free, evacuate with a deep vacuum pump. Triple evacuation to a maximum of 500 microns and nitrogen sweep is recommended. After the system has been thoroughly evacuated of all moisture and noncondensable gas, charge the system with the proper refrigerant, using “hi-side/low-side” charging techniques.

Do not exceed UL low side pressure rating when pressure testing Zero Zone cases.

Electrical

! **CAUTION!** DISCONNECT POWER TO THE CASE BEFORE SERVICING ELECTRICAL COMPONENTS TO AVOID PERSONAL INJURY AND DAMAGE TO THE UNIT.

For the typical wiring diagram for a low temperature case equipped with electric defrost **See Figure 27 on page 41.** For the typical wiring diagram for a low temperature case equipped with hot gas defrost **See Figure 28 on page 42.** For the typical wiring diagram for a medium temperature case **See Figure 31 on page 45.** Each case is provided with a wiring diagram located in the electrical enclosure that shows the exact wiring of the case.

There are many control options available for multiple case defrost systems. Wiring diagrams and instructions can be obtained by contacting Zero Zone's Service Department.

External wiring should be sized according to the amperage rating indicated on the serial plate. The serial plate is located on the ceiling inside the left-hand door. Typical electrical values for each of these cases are shown on specification sheets in the bag attached to the case or are available at www.zero-zone.com. All internal wiring has been done at the factory. Cases with standard wiring have their control wires terminated in the electrical enclosure located behind the kick rail at the right end of the case. A terminal block has been used to simplify field connections. An electrical box is mounted on the top of the unit for cases equipped with the optional top mount electrical connections.

All wiring must comply with the National Electrical Code and all local codes. After installation of the equipment, correct operation of the electrical circuits and controls and defrost operation and termination should be verified. All operating voltages and amperages should be measured and recorded.

INSTALLATION & OPERATION

OPTIONAL ELECTRICAL WIRING

Single Point Connection (Low Temp)

The “single point” connection system is designed to reduce the time required to install and wire one display case with one condensing unit. **See Figure 29 on page 43.**

All of the display case controls, including the disconnect switch and the electronic case controls are installed behind the kickplate in the electrical enclosure and prewired. The liquid line solenoid valve is installed in the liquid line and wired.

The power to operate the display case is connected at the case disconnect switch. The power to operate the condensing unit is connected in the condensing unit control panel. There are no interconnecting wires between the condensing unit and display case.

The controls operate the system as a pump down defrost. When the display case begins defrost, the liquid line solenoid valve, fans, and anti-sweat heaters are de-energized. The defrost heaters are energized. The compressor continues to run and pumps down the coil. The compressor cycles off on its low-pressure control. If there is any residual liquid left in the coil, the suction line pressure will rise and the compressor may turn on and pump down the coil.

The liquid line solenoid is energized at the end of the defrost cycle and the defrost heaters are de-energized. The suction line pressure rises and the compressor starts. When the low temperature evaporator reaches operating temperature, the fans and anti-condensate door heaters are energized.

Single Point Connection (Medium Temp)

The “single point” connection system is designed to reduce the time required to install and wire one display case with one condensing unit. For a typical diagram for this system **See Figure 32 on page 46.**

All of the display case controls, including the disconnect switch and electronic case controls, are installed behind the kickplate in the electrical enclosure and prewired. The liquid line solenoid valve is installed in the liquid line and wired.

The power to operate the display case is connected at the case disconnect switch. The power to operate the condensing unit is connected in the condensing unit control panel. There are no interconnecting wires between the condensing unit and display case.

The controls operate the system as a pump down defrost. When the display case begins defrost, the liquid line solenoid valve is de-energized. The fans and anti-sweat heaters remain energized during defrost. The compressor continues to run and pumps down the coil. The compressor cycles off on its low-pressure control. If there is any residual liquid left in the coil, the suction line pressure will rise and the compressor may turn on and pump down the coil.

The liquid line solenoid is energized at the end of the defrost cycle. The suction line pressure rises and the compressor starts.

Master Satellite Connection (Low Temp)

The “master satellite” connection system allows one condensing unit to be connected to multiple cases. For a typical diagram for this system **See Figure 30 on page 44.**

All of the display case controls, including the disconnect switch, time clock, temperature control, and defrost temperature control, are installed behind the kickplate in the electrical enclosure and prewired. The liquid line solenoid is prewired but is not installed in the liquid line.

The power to operate each display case is connected at each case’s disconnect switch. The power to operate condensing unit is connected at the condensing unit. There are no interconnecting wires between the condensing unit and display case. There are interconnecting wires that need to be connected between the cases. The liquid line solenoid valve needs to be installed in the common liquid line before the liquid is distributed to the cases.

The controls operate the system as a pump down defrost. When the display case begins defrost, the liquid line solenoid valve, fans, and anti-sweat heaters are de-energized. The defrost heaters are energized. The compressor continues to run and pumps down the coil.

INSTALLATION & OPERATION

The master case contains the time clock. Interconnecting case wiring allows the master case to control the satellite cases. When defrost is initiated in the master case, it sends an electrical signal to each case to energize the defrost relay and initiate a defrost in all of the satellite cases. A second set of interconnecting wires is connected in series between each of the cases. Each case defrost heater is de-energized when the coil reaches the defrost termination temperature. An additional signal is relayed to the next case indicating that the termination temperature has been reached. When all of the cases have reached termination temperature, the defrost termination circuit is complete and the defrost is terminated.

The liquid line solenoid is energized at the end of the defrost cycle and the defrost heaters are de-energized. The suction line pressure rises and the compressor starts. When the evaporator reaches operating temperature, the delay thermostat (Klixon) will close, energizing the fans and anti-sweat door heaters.

Note: When using a Carel controller, the system will still function as a pump down system, but the Carel defrost function controls the defrost termination of each case independently and requires a defrost sensor coming from each satellite case to the master case. Contact the Zero Zone Service Department for specific operating characteristics.

Master Satellite Connection (Medium Temp)

The “master satellite” connection system allows one condensing unit to be connected to multiple cases. See Figure 30 on page 44 and See Figure 31 on page 45.

All of the display case controls, including the disconnect switch, time clock, and temperature control, are installed behind the kickplate and prewired. The liquid line solenoid is prewired but is not installed in the liquid line.

The power to operate each display case is connected at each case’s disconnect switch. The power to operate the condensing unit is connected at the condensing unit. There are no interconnecting wires between the condensing unit and display case. There are interconnecting wires that need to be connected between the cases. The liquid line solenoid valve needs to be installed in the common liquid line before the liquid is distributed to the cases.

The controls operate the system as a pump down defrost. When the display case begins defrost, the liquid line solenoid valve is de-energized. The compressor continues to run and pumps down the coil.

The master case contains the time clock. Interconnecting case wiring allows the master case to control the satellite cases. When defrost is initiated in the master case, it sends an electrical signal to each case to initiate a defrost in all of the satellite cases. A second set of interconnecting wires is connected in series between each of the cases.

The liquid line solenoid is energized at the end of the defrost cycle. The suction line pressure rises and the compressor starts.

Defrosting - Low Temp

GENERAL

Periodic defrosting to keep the coil free of frost is accomplished automatically by a time clock used in conjunction with an electric or hot gas defrost method.

For best results, temperature termination of defrost is strongly recommended on Zero Zone cases.

DEFROST SETTINGS AND CONTROLS

Electric Defrost

Frequency: One electric defrost per day is recommended.

Time of day: Nighttime defrosting is preferred to avoid periods of shopping or stocking.

INSTALLATION & OPERATION

Drip Time: Electric defrost does not require any drip time. The fans should not operate until the coil temperature is below freezing. The Zero Zone standard case includes a fan delay thermostat that prevents the fans from operating until the coil is below freezing. Cases utilizing electronic controls may utilize a coil temperature sensor to control fan operation instead of a fan delay thermostat.

Electric Defrost Fail-safe Times:

	ICE CREAM	FROZEN FOOD
RHZC30	1/day at 55 mins	1/day at 55 mins
RHZC30T	1/day at 55 mins	1/day at 55 mins

At ASHRAE test conditions and 208 volt defrost heater operation, the typical observed RHZC30 defrost durations are 55 minutes for ice cream and 55 minutes for frozen food. At the same conditions, the typical observed RHZC30T defrost durations are 55 minutes for ice cream and 55 minutes for frozen food.

Preferred Termination: For optimal performance, Zero Zone recommends a temperature-terminated defrost, using a defrost termination thermostat or probe sensing the coil temperature.

The RHZC30 and RHZC30T door case has the probe located in the center/bottom of the coil.

An adjustable defrost termination thermostat is an available option from Zero Zone. If the case is so equipped, the defrost termination temperature is 50°F. Contractor should verify the 50°F setting.

Temperature termination based on coil temperature allows the length of defrost to vary depending on how much frost is on the coil and the defrost heater voltage. Coil frost is a function of shopping patterns, stocking habits, general door maintenance, and ambient temperature and humidity. More frost requires a longer defrost. A lower defrost heater voltage extends the defrost period.

Zero Zone electric defrost freezers are delivered with the defrost thermostat open-on-rise contacts wired in series with the defrost heaters. Unless the installer rewires the defrost thermostat, the defrost heater is de-energized when defrosting is complete.

Zero Zone RHZC30 and RHZC30T door electric defrost freezers are also equipped with a high-limit, snap-disc thermostat that de-energizes the defrost heater if the coil temperature exceeds 85°F to provide a secondary safety termination.

Hot Gas Defrost

Frequency: One hot gas defrost per day is recommended.

Time of day: Nighttime defrosting is preferred to avoid periods of shopping or stocking.

Drip time: Hot gas defrost requires a 5 minute drip time.

Hot Gas Defrost Fail-safe Times:

	ICE CREAM	FROZEN FOOD
RHZC30 / RHZC30T Hot Gas	1/day at 30 mins 5 min drip	1/day at 30 mins 5 min drip
RHZC30 / RHZC30T Reduced Temp Gas	1/day at 40 mins 5 min drip	1/day at 40 mins 5 min drip

Preferred Termination: For optimal performance, Zero Zone recommends a temperature-terminated defrost, using a defrost termination thermostat or probe attached to the dump line.

At ASHRAE test conditions, termination ranges from 12-22 minutes. Measure dump line temperature, and time how long it takes to reach 65°F. Add 5 minutes for time termination setting plus drip time.

INSTALLATION & OPERATION

An adjustable defrost termination thermostat is an available option from Zero Zone. If the case is so equipped, the defrost termination temperature is 65°F at the dump line. Contractor should verify the 65°F setting.

Electric Defrost Operation

The compressor stops when the defrost is initiated in a non-pump-down system. On pump-down systems, the liquid line solenoid will be de-energized when the defrost is initiated. The clock will energize the 208/230 volt defrost heater, and energize the normally closed 208/230 volt contactor or relay. This de-energizes the 115-volt fans, lights, and anti-sweat heaters. If you don't have a light circuit limit thermostat, the lights will not de-energize.

After the defrost period, the compressor will operate. When the coil temperature reaches +5°F, the fan thermostat (Klixon) will close, starting the fans. **See Figure 34 on page 48.**

Gas Defrost Operation

Several types of gas defrost methods (using time-actuated, time-terminated, or temperature-terminated defrost timers) can be used to defrost the evaporator.

The refrigeration system designer and installer are responsible for correct line sizing for effective gas defrost and liquid return from the freezers. Sizing and component selection depend on the type of defrost, size, and location of high side refrigeration system.

Zero Zone freezers equipped for gas defrost consist of a side port distributor and a TXV check valve for coil defrost, and a suction line check valve to bypass hot gas to the serpentine coil. The serpentine coil is attached to the bottom of the pan to ensure pan and drain defrost.

The timer starts the gas defrost cycle by energizing a solenoid, reversing valve, or directional valve. The gas is injected from the source into the suction line of the evaporator to be defrosted. The gas flows into the serpentine coil attached to the floor of the case and then into the evaporator. Condensed liquid leaves the evaporator through the side port distributor, through a check valve into the liquid line. **See Figure 33 on page 47.**

General Notes

- The refrigeration technician should recheck coil condition after one week of retail operations to be certain that the frequency and duration of defrost is adequate for the particular store and conditions. For example, if defrost voltage is below 200 volts, additional fail-safe time may be required.
- When using time-terminated defrost, defrost termination thermostat should be wired in series with the defrost heater.
- Defrost termination thermostats may be wired in series for multiple evaporator installations.
- Defrost termination thermostats may be used as a digital input for electronic controllers.

Limit Thermostat

The Zero Zone standard case includes a factory set limit thermostat (Klixon) attached to the return bend of the coil on the right end of the freezer to regulate the operation of the evaporator fans. If selected by the customer, the lights may be controlled by a second limit thermostat. Cases utilizing electronic controls may utilize a coil temperature sensor to control operation of the fans and lights instead of a limit thermostat.

IMPORTANT! OPERATION OF THE LIMIT THERMOSTATS CAUSES THE EVAPORATOR FANS TO REMAIN OFF UNTIL THE COMPRESSOR IS OPERATING AND THE COIL TEMPERATURE IS BROUGHT BELOW THE THERMOSTAT CUT-IN SETTING (+5°F). SUPERHEAT MUST BE SET CORRECTLY BY THE INSTALLING CONTRACTOR FOR PROPER THERMOSTAT OPERATION.

When the freezer first operates, the fans and lights may cycle off and on a few times until coil temperature is below +5°F. The superheat must be set for proper operation.

Electric defrost models have a high limit thermostat installed on the coil return bend, wired in series with the defrost heaters. This thermostat opens when the temperature reaches 85°F.

INSTALLATION & OPERATION

DEFROST HEATER ELEMENT

On 30" door cases, one half of the U-shape heater is located on the front of the coil and the other half is located on the rear of the coil. . The electric wire leads are connected in the junction box behind the front kick rail.

HEATER ELEMENT REMOVAL

Front and Rear Heater Location (RHZC30 and RHZC30T)

The U-shape defrost heater has one leg located on the front of the coil and one leg located on the rear of the coil. The front heater is located approximately 1" off the floor and the rear heater is approximately 2" off the floor. The heater is secured to the coil by a number of stainless steel heater retaining clips. The heater is fastened to the floor on the right-hand side of the coil. Remove fasteners holding the heater to the floor.

The U-shape defrost heater can be removed by first pulling the front leg of the retaining clip away from the coil and sliding the heater out from under the clip. The rear leg of the heater can then be removed by raising the retaining clips 2 inches at a time, working from right to left on the coil. Repeat this process until the retaining clips are free of the coil. The heater will slide up with the retaining clip.

Heaters are installed in the reverse order of how they were removed.

Defrosting - Medium Temp

GENERAL

Periodic defrosting to keep the coil free of frost is accomplished automatically by a time clock. Medium temperature cases generally operate at temperatures that allow for off-cycle defrost. Medium temperature cases used for fresh meat products are often set to run slightly colder than ordinary refrigerated cases. For evap temps down to 25°F, ordinary off-cycle defrost cycles at 2 per day usually defrosts adequately and still keeps meat fresher longer than open cases. For operators that want to soft freeze their meat (i.e., evaporator temps colder than 25°F), an optional electric or hot-gas defrost may become necessary to ensure a complete defrost depending on the application.

DEFROST SETTINGS AND CONTROLS

Off-Cycle Defrost

Frequency: Two off-cycle defrosts per day are recommended.

Duration: Generally defrost is terminated on time with the recommended setting of 30 minutes. If temperature termination is selected, the termination temperature is set for 45°F for discharge air and coil temperature. Stocking or shopping activities during temperature-terminated defrost may result in premature defrost termination.

ELECTRIC AND HOT GAS DEFROST

Follow the setting recommendations found in the section "[Defrosting - Low Temp](#)" on page 14.

DEFROST OPERATION

Off-Cycle

For off-cycle defrost, refrigeration to the unit is stopped either by stopping the compressor or closing the liquid line solenoid valve and allowing the compressor to pump down. During an off-cycle defrost, the fans, lights, and anti-sweat heaters remain on.

INSTALLATION & OPERATION

Electric and Hot Gas

For a description of these defrost types, see "[Defrosting - Low Temp](#)" on page 14.

Anti-Sweat Heaters - Low Temp

The case has one anti-sweat heater located in each mullion, including the end mullions, and one anti-sweat heater in the case sill. The mullion heater is located behind the front metal strike plate. Remove the front fasteners on the mullion and remove the back plastic of the mullion to access the heater. The case sill heater is located under the front metal strike plate below the door opening. Contact Zero Zone's Service Department for instructions for servicing this heater.

For locations with low humidity and tightly controlled ambient conditions, the lower sill heater may be disconnected for additional energy savings.

Anti-Sweat Heaters - Medium Temp

The case has one anti-sweat heater located in each mullion, including the end mullions, and one anti-sweat heater in the case sill. The mullion heater is located behind the front metal strike plate. Remove the front fasteners on the mullion and remove the extrusion to access the heater. Contact Zero Zone's Service Department for instructions for servicing this heater.

Doors

For detailed information on the doors, call the Zero Zone Service Department.

ILLUSTRATIONS

Case Label Information

FIGURE 1: CASE LABEL LOCATIONS

2-B	2-B	2-A	2-A
1-A	1-A	1-B	1-B

FRONT OF LINEUP

CASE JOINT LABELS

1-A1	1-A1	1-B1	1-B1
1-A	1-A	1-B	1-B

FRONT OF LINEUP

BACK TO BACK CASE JOINT LABELS

ILLUSTRATIONS

Leveling

FIGURE 2: Leveling Cases Prior to Joining

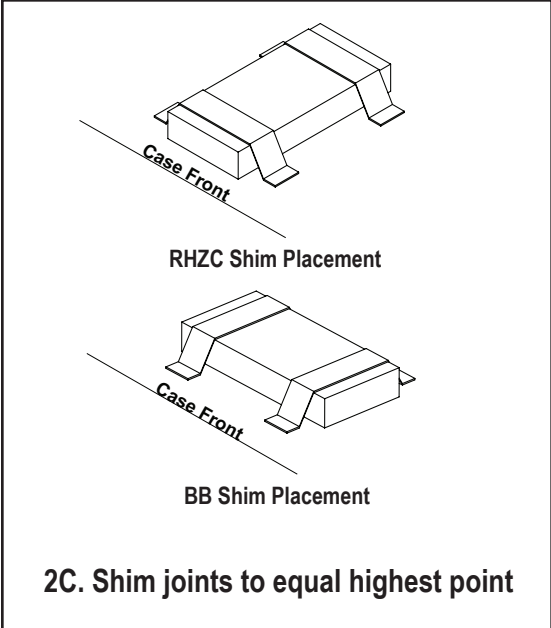
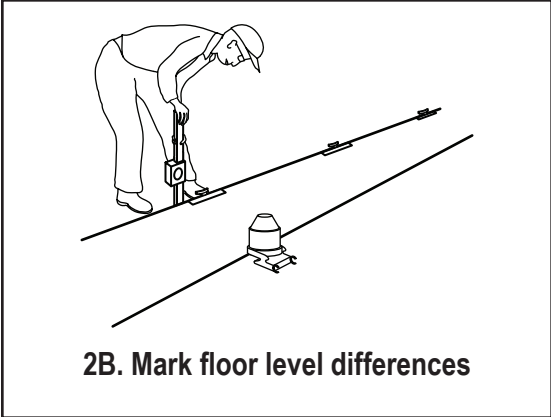
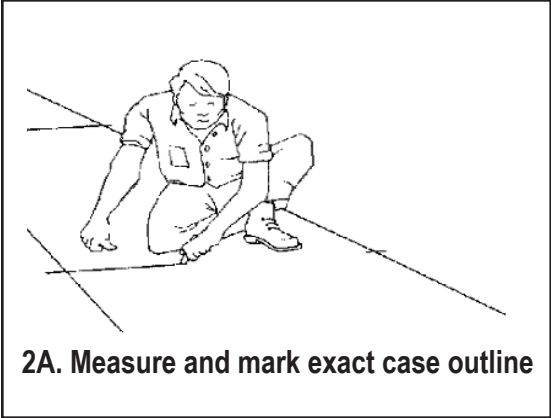

ILLUSTRATIONS

Leveling

FIGURE 3: Positioning Hat Channel Rails



ILLUSTRATIONS

Leveling

FIGURE 4: Typical Rail Locations

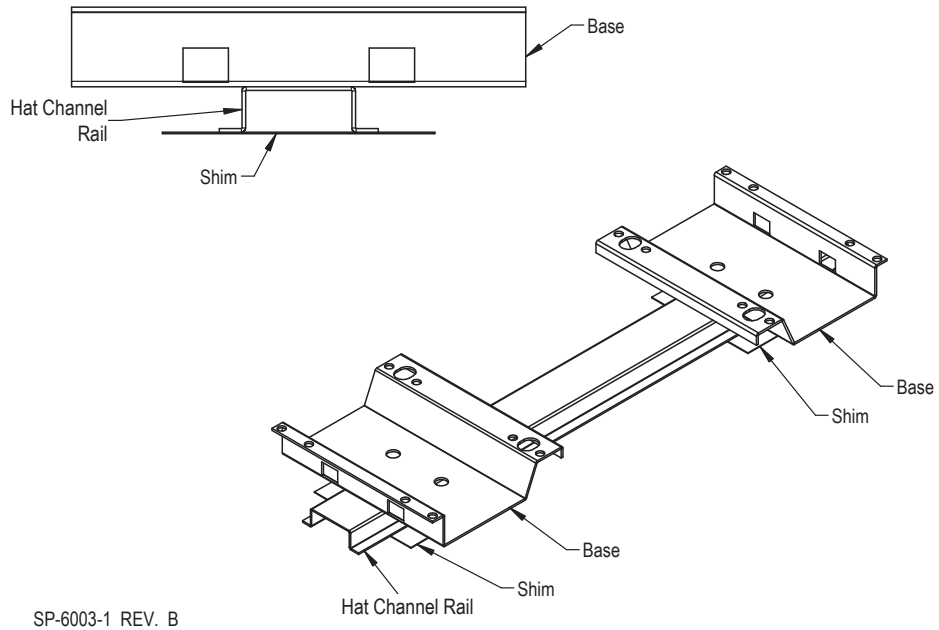
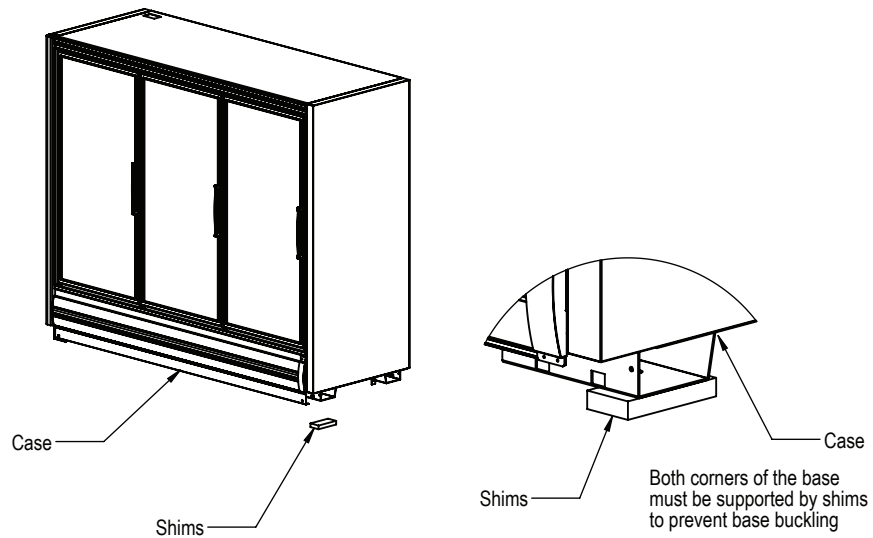

FIGURE 5: Shims Under Bases and Case



DWG. NO. SP-6006-1 REV. A

ILLUSTRATIONS

Leveling

FIGURE 6: Base Locations

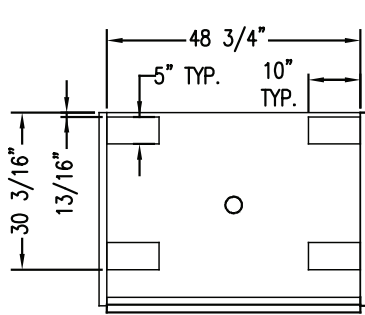

6A. 24" 2-Door Case

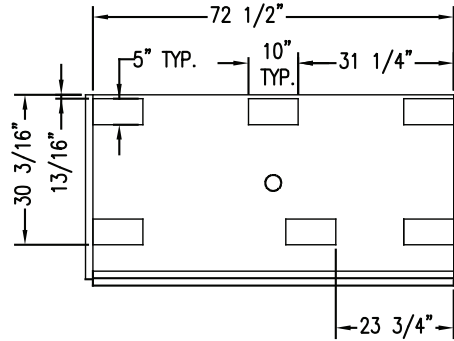

6B. 24" 3-Door Case

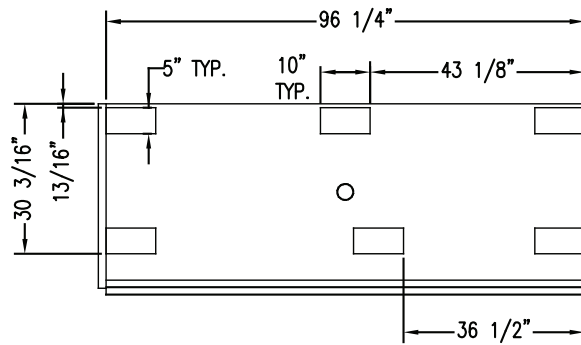

6C. 24" 4-Door Case

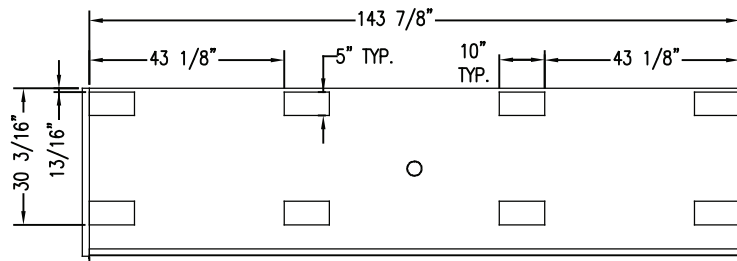

6D. 24" 6-Door Case

ILLUSTRATIONS

Leveling

Figure 6: Base Locations (Cont.)

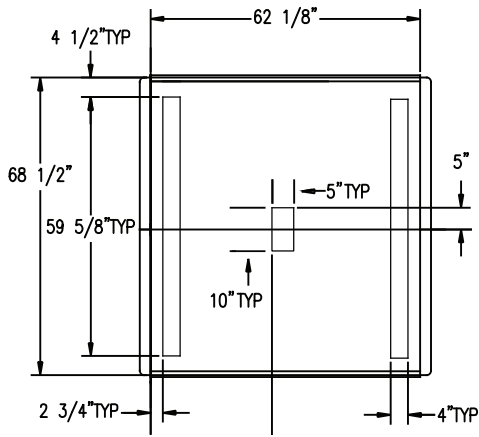

6E. 30" 2-Door Back-to-Back Case

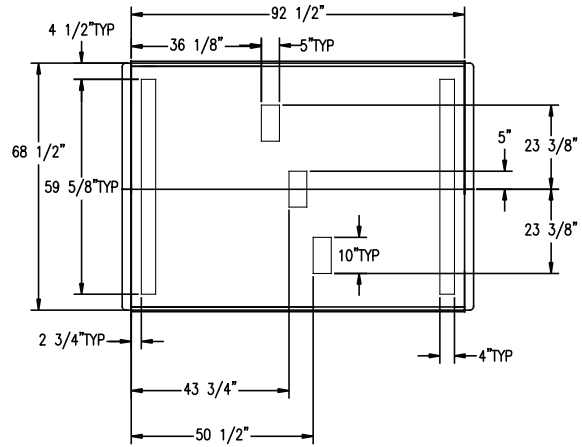

6F. 30" 3-Door Back-to-Back Case

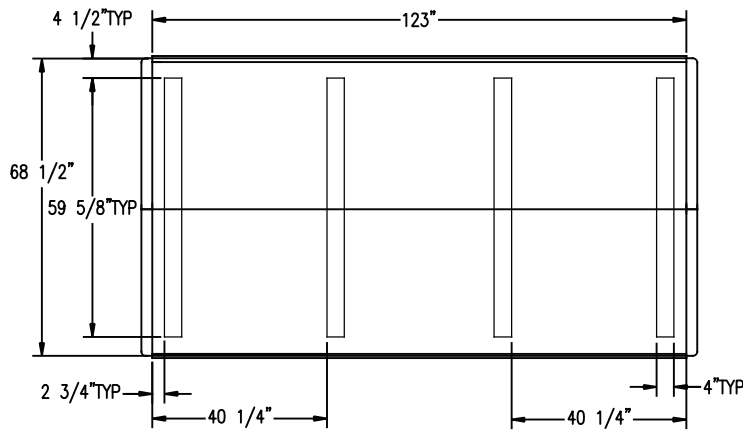

6G. 30" 4-Door Back-to-Back Case

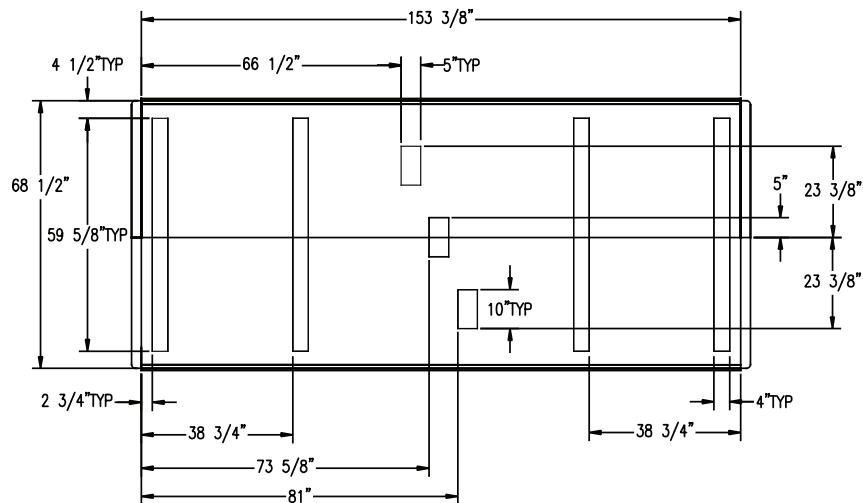

6H. 30" 5-Door Back-to-Back Case

ILLUSTRATIONS

Leveling

Figure 6: Base Locations (Cont.)

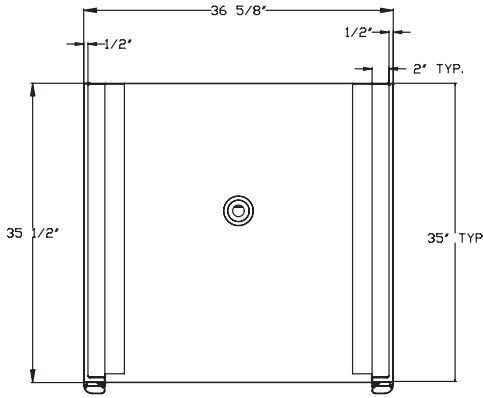

6I. 30" 1-Door Case

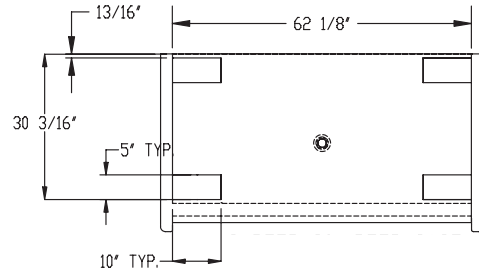

6J. 30" 2-Door Case

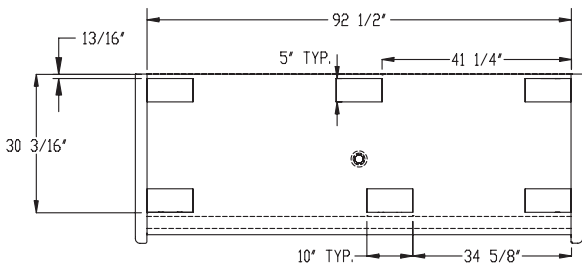

6K. 30" 3-Door Case

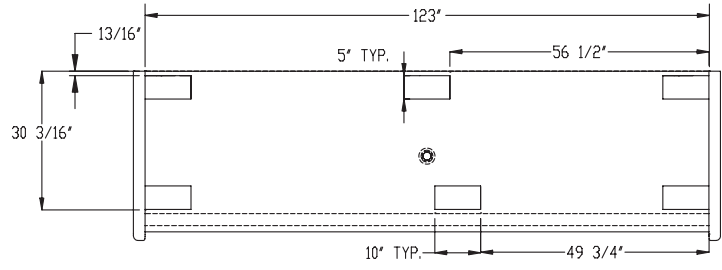

6L. 30" 4-Door Case

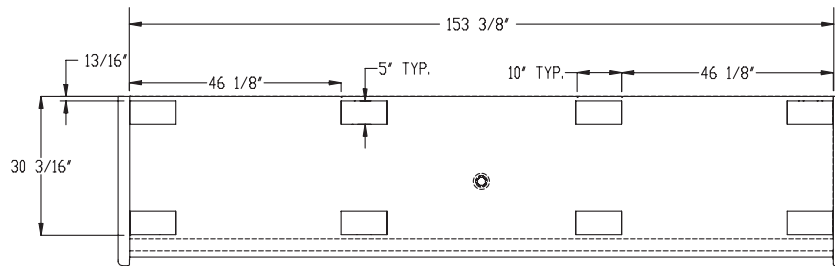

6M. 30" 5-Door Case

ILLUSTRATIONS

Moving Cases

FIGURE 7: REMOVING WOOD PLANKS

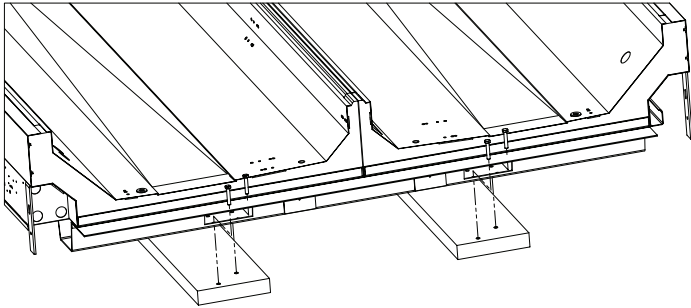

FIGURE 8: WOOD BLOCK INSIDE BASE

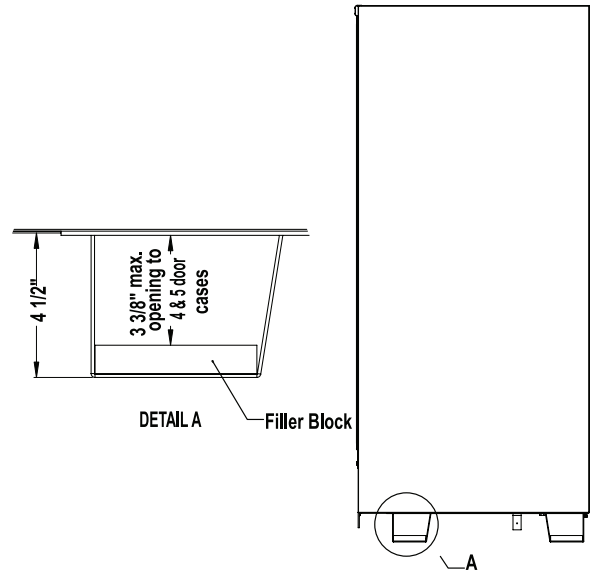
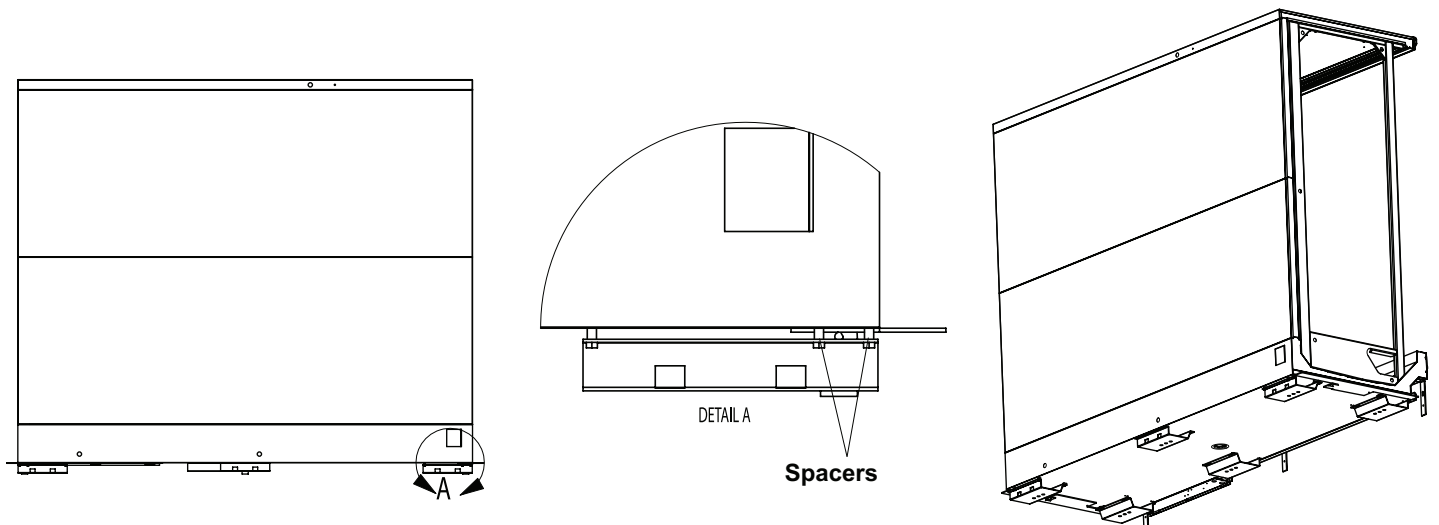

FIGURE 9: EXPANDABLE BASE



ILLUSTRATIONS

RHZC / RHCC Caulking Instructions

FIGURE 10

FOLLOWING THIS PROCEDURE IS CRITICAL FOR SEALING JOINED CASES CORRECTLY!

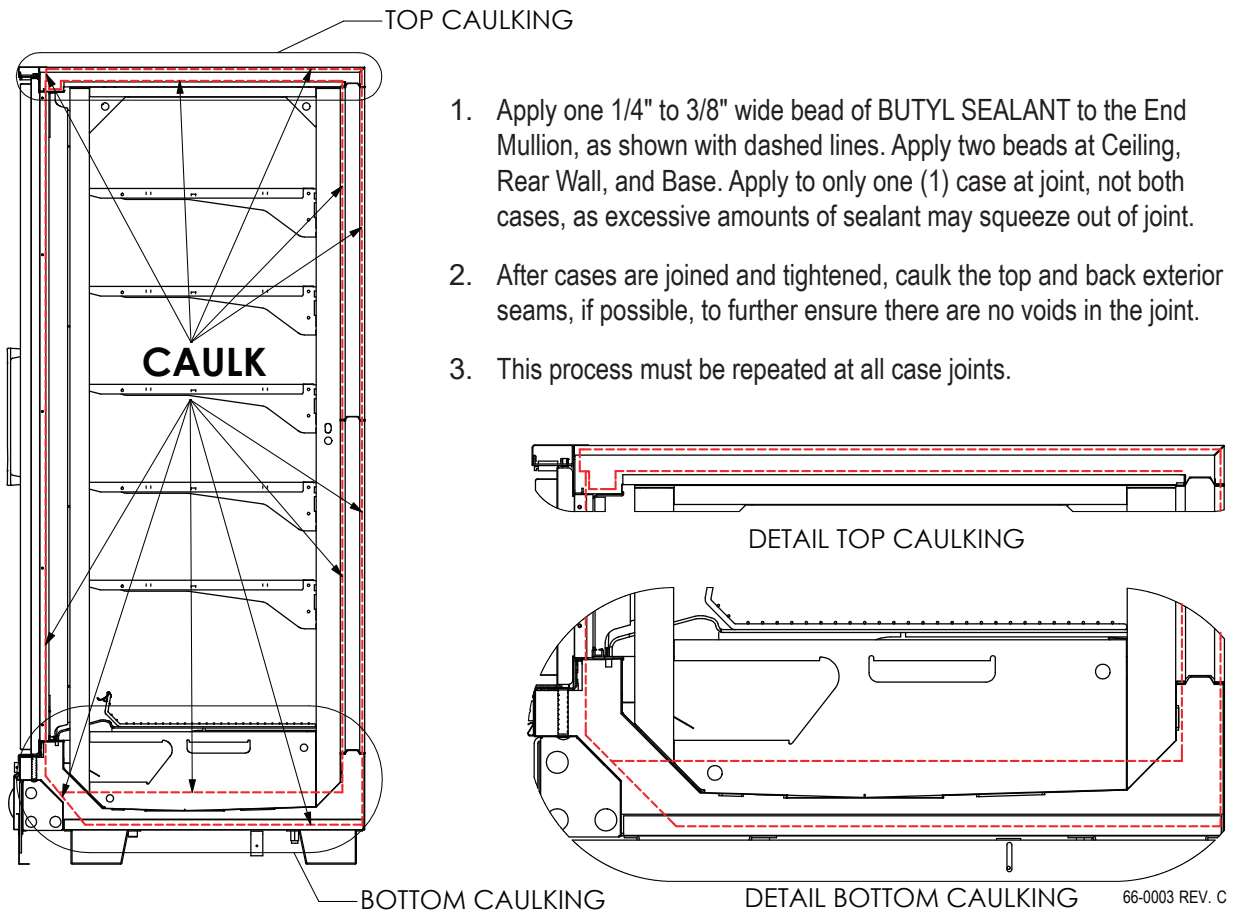

ILLUSTRATIONS

Required Sealing for NSF-Approved Installations

FIGURE 11

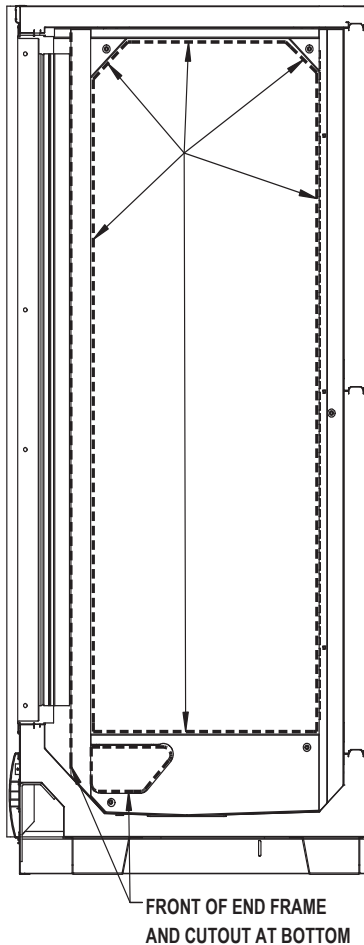

REQUIRED SEALING FOR NSF APPROVED INSTALLATION ONLY

SURFACES OF AREAS TO BE CAULKED SHOULD BE CLEAN, DRY, AND FREE OF FROST. SURFACE TEMPERATURE OF THESE AREAS SHOULD BE ABOVE 40°F.

1. Cases to be joined properly before continuing to step 2. Refer to CASE – JOINT CAULKING INSTRUCTION for more information. This document is included in your information packet. Avoid excess caulk during this step to prevent it from coming out of the joints. This will affect step 2 as butyl and silicone sealants do not mix.
2. Apply silicone-based caulk-sealant bead to areas shown at left to meet sealant requirements for NSF-approved installations.
3. Apply small beads of sealant smoothly at seams between end frame of case and end panel or insulated divider, but do not thin or feather excessively, because it may affect adhesion.

NOTE: Caulk sealant lines are shown dashed in views at left. Field caulk sealant must be applied in a continuous fashion to seal the affected area with the desired bead width and penetration.

FIGURE 12: JOINING 24" AND 30" DOOR CASES

66-0007-P1 CASE JOINING HARDWARE KIT			
ITEM NO.	PART NUMBER	DESCRIPTION	QTY.
1	64-0287-P1	SCREW 3/8-16X1 HEX CAP GR 2 BLK ZN	5
2	64-0034-P1	WASHER 3/8 STD FLAT ZP BLK	10
3	64-0064-P1	NUT 3/8-16 NC HEX NUT ZP BLK	5
4	64-0127-1	SCREW 8 X 1/4 PHIL PAN HD SMS BLK ZP	8
5	82-0006	CAULK BUTYL/TUBES WHT	2

NOTES:

1. ITEM #4 USED ON HZ/C AND VLC CASES ONLY.
2. JOINING STRIP SHIPPED LOOSE.
3. SEE 66-0024 FOR VZ/C AND VMC JOINING STRIP HARDWARE.
4. ITEM 5 CAULK NOT SHOWN.

66-0007-P9 CASE JOINING HARDWARE KIT			
ITEM NO.	PART NUMBER	DESCRIPTION	QTY.
1	64-0287	SCREW 3/8-16X1 CAP GR 2 ZNC	5
2	64-0034	WASHER 3/8 STD FLAT ZP	10
3	64-0064	NUT 3/8-16 NC HEX NUT ZP	5
4	64-0127-1	SCREW 8 X 1/4 PHIL PAN HD SMS BLK ZP	8
5	82-0006	CAULK BUTYL/TUBES WHT	2

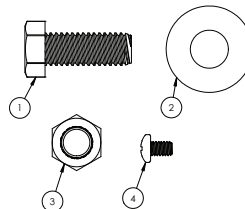

ILLUSTRATIONS

Joining Insulated Dividers - RHZC / RHCC to RHZC / RHCC

FIGURE 13

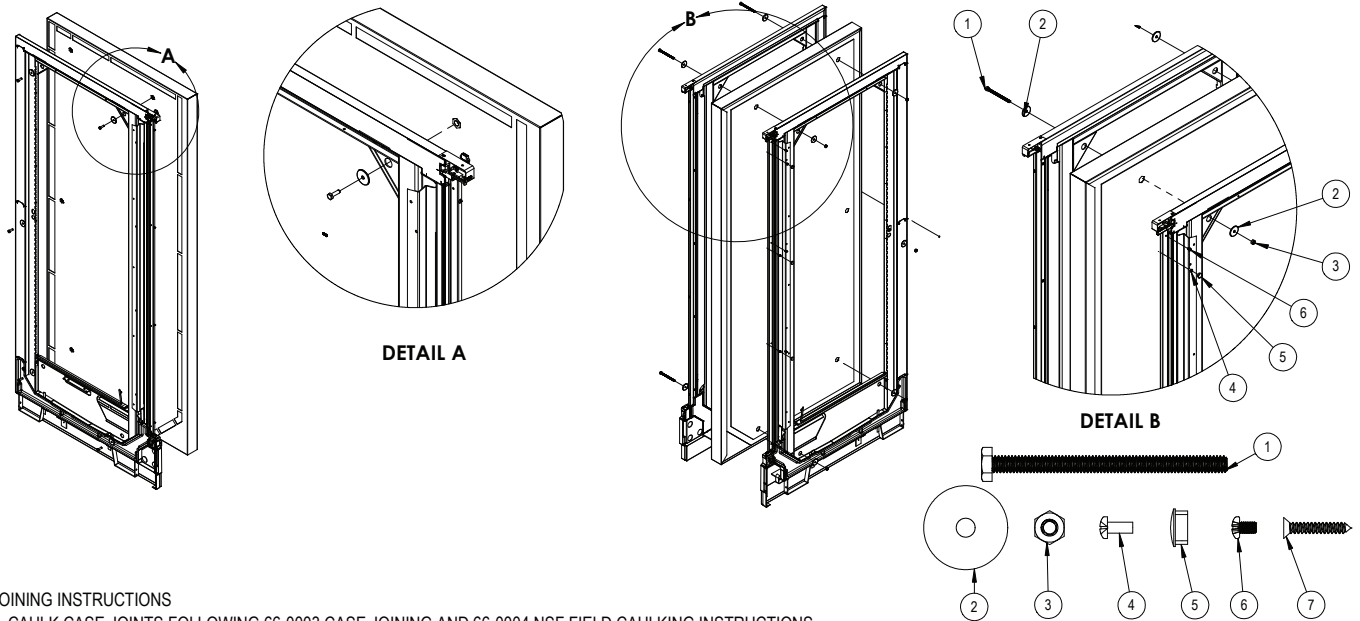

JOINING INSTRUCTIONS

1. CAULK CASE JOINTS FOLLOWING 66-0003 CASE JOINING AND 66-0004 NSF FIELD CAULKING INSTRUCTIONS.
2. ALIGN OPPOSITE ENDS OF TWO CASES TO BE JOINED.
3. THERE ARE 5 BOLTS AND WASHERS FACTORY INSTALLED HOLDING THE INSULATED DIVIDER TO CASE (SEE DETAIL A). REPLACE EACH OF THESE BOLTS AND WASHERS 1 AT A TIME. DO NOT REMOVE DIVIDER FROM CASE.
4. REMOVE ONE BOLT AND WASHER, REPLACE WITH ITEMS 1 AND 2. ITEM 1 WILL GO THROUGH THE WHOLE INSULATED DIVIDER INTO OTHER CASE, WHERE YOU WILL ATTACH ITEMS 2 AND 3. (SEE DETAIL B). HAND TIGHTEN.
5. REPEAT STEP 4 UNTIL ALL FACTORY INSTALLED HARDWARE HAS BEEN REMOVED.
6. MAKE SURE INSULATED DIVIDER IS ALIGNED WITH CASE.
7. ALTERNATE TIGHTENING EACH NUT AND BOLT EQUALLY UNTIL THE CASES ARE JOINED TOGETHER EVENLY, FORMING A TIGHT SEAL BETWEEN THE INSULATED DIVIDER AND THE CASE. DO NOT USE THE HARDWARE TO PULL THE CASES TOGETHER.
8. INSTALL ITEM 6 INTO VERTICAL RACEWAY COVER (4 PLACES). THIS WILL FASTEN TO THE VERTICAL RACEWAY.
9. INSTALL ITEM 4 INTO VERTICAL RACEWAY COVER (4 PLACES). THIS WILL FASTEN TO THE INSULATED DIVIDER.
10. INSTALL ITEM 5 INTO VERTICAL RACEWAY COVER (4 PLACES). THIS WILL COVER THE PREVIOUSLY INSTALLED SCREWS.
11. INSTALL ITEM 7 INTO FRAME WHEN JOINING EVOLUTION TO INSULATED DIVIDER (4 PLACES).
12. MIRROR JOINING INSTRUCTIONS IF INSULATED DIVIDER IS ON OPPOSITE SIDE OF CASE.

HARDWARE			
ITEM NO.	PART NUMBER	DESCRIPTION	QTY
1	64-0406	BOLT 1/4-20X 3-1/2 HEX TAP GR 8 ZN	5
2	64-0199	WASHER FNDR ZP 9/32 ID 1-1/4 OD	10
3	64-0308	NUT HEX 1/2-20 FINISH GR 8 ZN/YE	5
4	64-0610	SCREW 8-15 X 3/8 HES HD ZP TYPE A	4
5	64-0527-P1	HEYCO SHORTY HOLE PLUG, BLACK	4
6	64-0127	SCREW 8 X 1/4 PHIL PAN HD SMS ZP	4
7	64-0269	SCREW #8-18X1" PH FLAT T/S/AB/STLZN	4
8	82-0006	CAULK BUTYL/TUBES WHT	4

*** ITEMS 1, 2, 3, AND 7 PART #S END WITH A -P1 FOR BLACK INTERIOR.

ILLUSTRATIONS

Joining Insulated Dividers - RHZC / RHCC to RVLC / RVMC

FIGURE 14

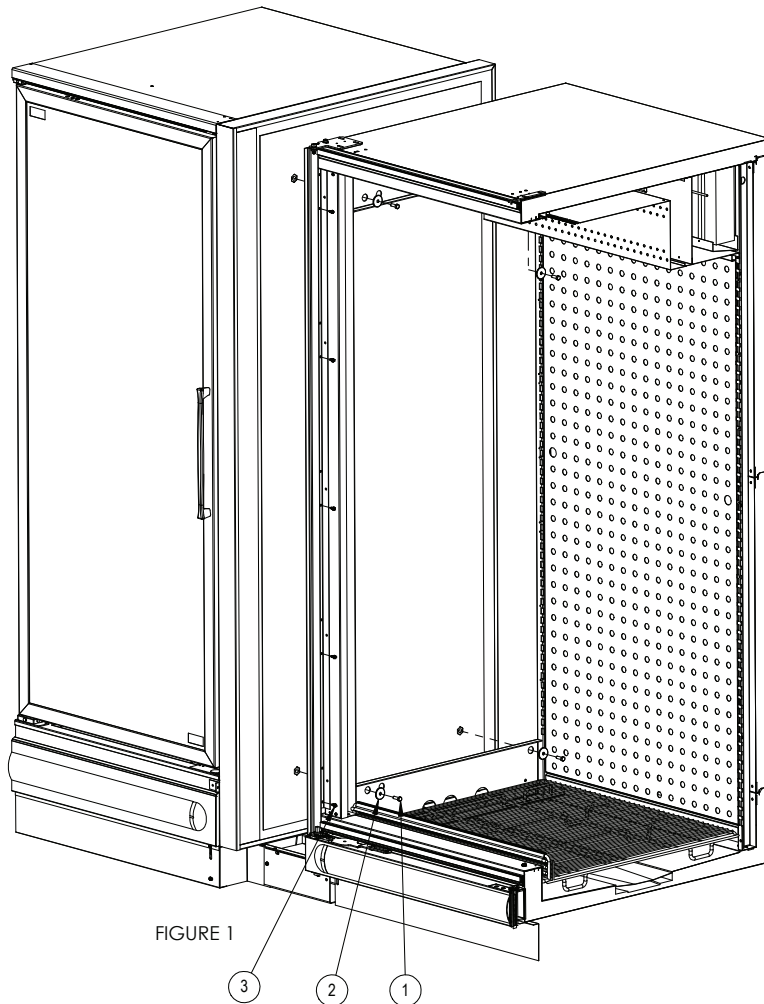

FIGURE 1

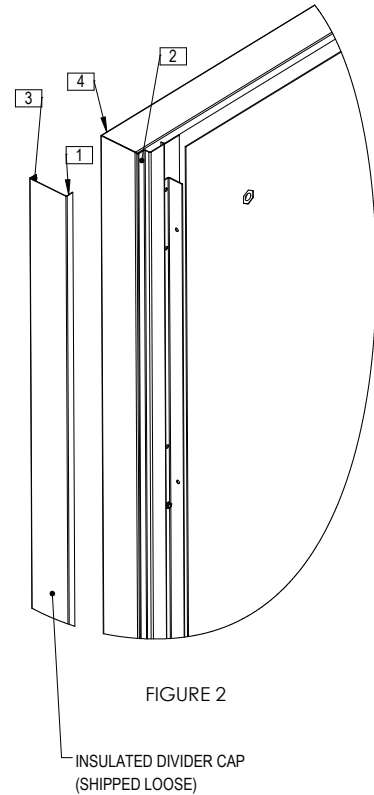
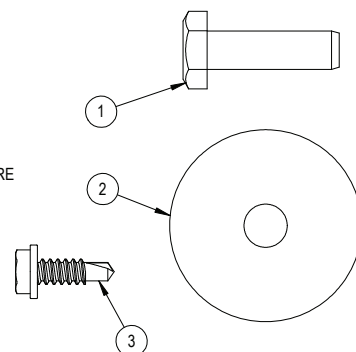

FIGURE 2

INSULATED DIVIDER CAP
(SHIPPED LOOSE)

INSTALLATION INSTRUCTIONS

1. CAULK CASE JOINT/S FOLLOWING 66-0003 CASE JOINING AND 66-0004 NSF FIELD CAULKING INSTRUCTIONS.
2. ALIGN CASES ACCORDING TO INSTALLATION AND OPERATION MANUAL.
3. INSERT ITEMS 1 AND 2 INTO MOUNTING HOLES AND FASTEN INTO INSULATED DIVIDER BACKER PLATES. FOR BLACK INTERIOR, USE BLACK FASTENERS. FOR ALL OTHER INTERIOR COLORS, USE ZINC PLATED FASTENERS. (SEE FIGURE 1.)
4. ONCE CASES ARE JOINED PROPERLY, OPEN DOOR ON CRYSTAL COOLER, AND INSERT ITEM 3 INTO ALIGNED HOLES, SECURING THE DOOR SEAL BRACKET TO THE INSULATED DIVIDER ON HIGHLIGHT FREEZER. (SEE FIGURE 1).
5. REMOVE DOUBLE SIDED TAPE BACKING FROM INSULATED DIVIDER CAP. ATTACH INSULATED DIVIDER CAP BY SLIDING FACE [1] OVER FACE [2]. ROLL TO THE LEFT, SLIDING FACE [3] OVER FACE [4]. (SEE FIGURE 2).
6. DO NOT USE BOLTS TO PULL CASES TOGETHER.



66-0026 HZ/C/VMC INSULATED DIVIDER JOINING KIT			
ITEM NO.	PART NUMBER	DESCRIPTION	QTY.
1	64-0106-1	BOLT 1/4-20X7/8 NC HEX H BLKZPGRD 5	4
1	64-0106	BOLT 1/4-20X 7/8NCHEXHDCAPSCS GRD5	4
2	64-0199-P1	WASHER FNDR 9/32 ID 1-1/4 OD BLK	4
2	64-0199	WASHER FNDR ZP 9/32 ID 1-1/4 OD	4
3	64-0207-P1	SCREW .8-18X1/2"HEX WSHR BLK	5
6	82-0006	CAULK BUTYL/TUBES WHT	4

ILLUSTRATIONS

Attaching Kickplate Splice - RHZC / RHCC to RVLC / RVMC

FIGURE 15

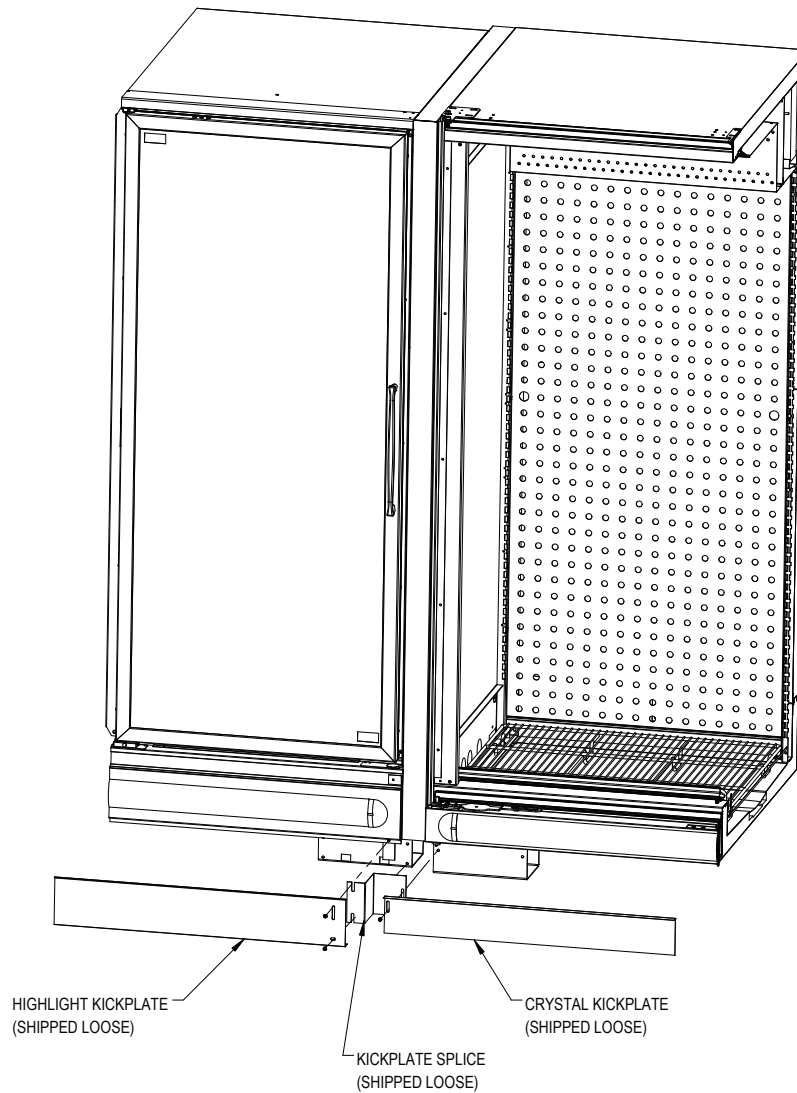

INSTALLATION INSTRUCTIONS

1. ALIGN KICKPLATE SPLICE WITH HOLES IN CRYSTAL BASE AND HIGHLIGHT KICKPLATE BRACKET.
2. INSTALL CRYSTAL KICKPLATE.
3. INSTALL HIGHLIGHT KICKPLATE.

ILLUSTRATIONS

Field-Mounted Trap

FIGURE 16

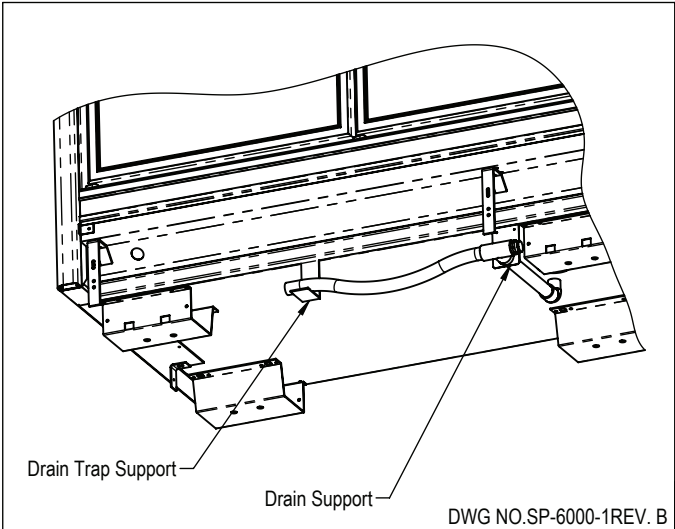

ILLUSTRATIONS

FIGURE 17: BUMPER STYLES

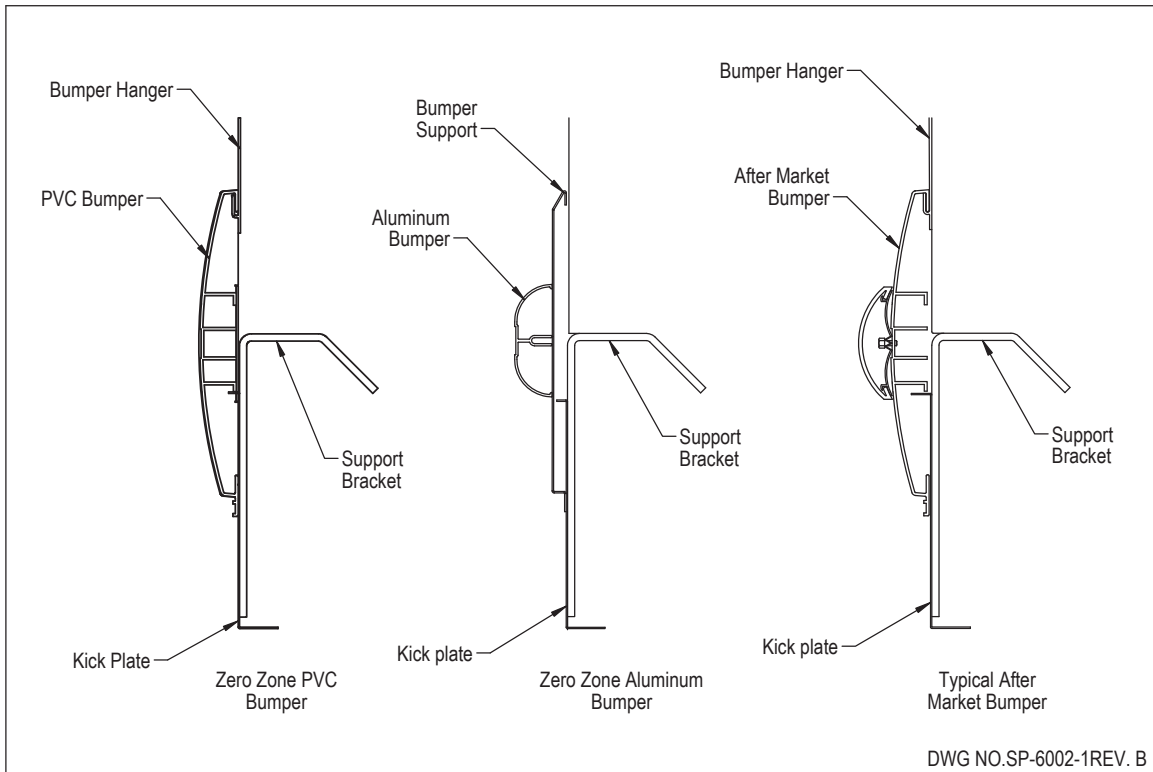
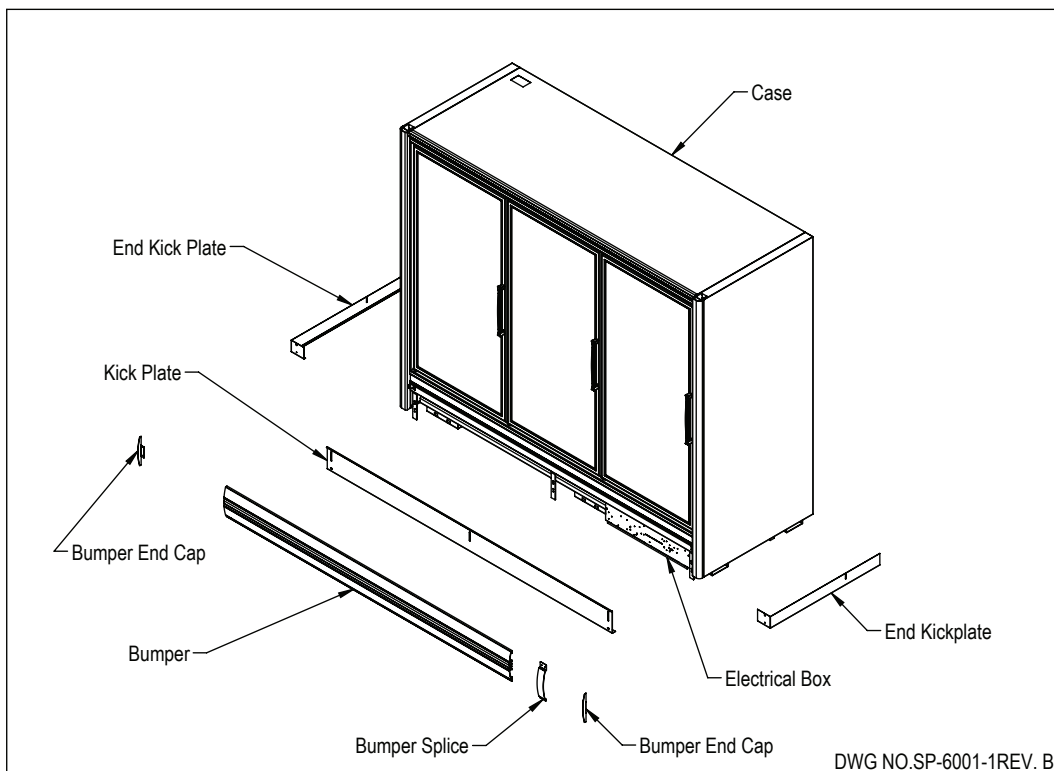

FIGURE 18: INSTALLING BUMPER AND KICKPLATE



ILLUSTRATIONS

Under Case Return Air Flow

FIGURE 19:

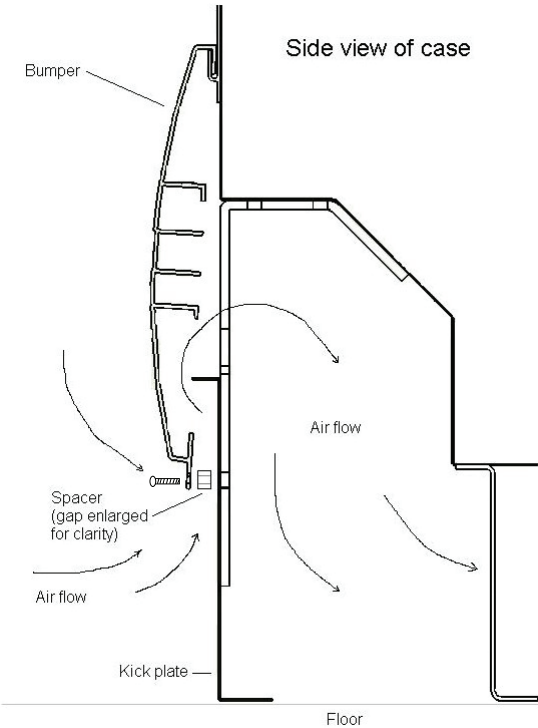

ILLUSTRATIONS

Penetration Sealing

FIGURE 20:

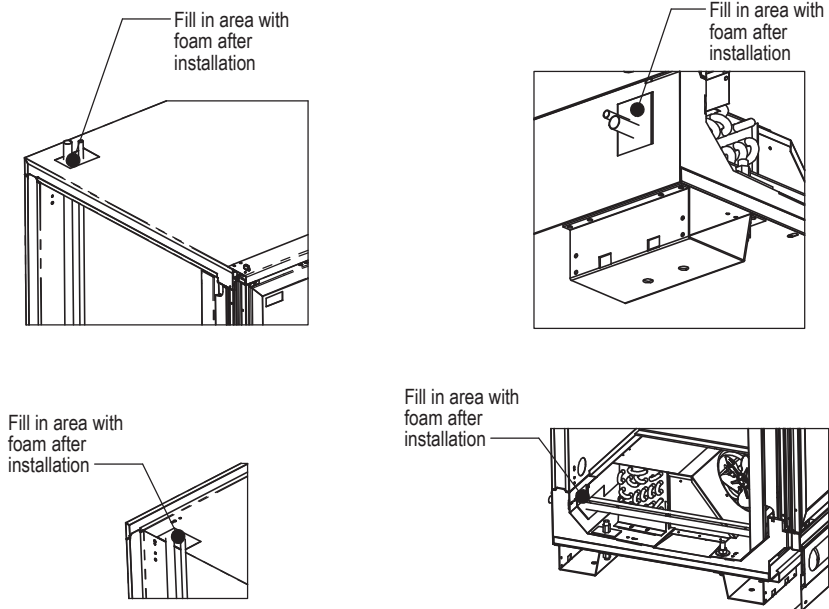

DWG. NO. SP-6007-1 REV. B

ILLUSTRATIONS

P-trap Installation

FIGURE 21: 45° ELBOW SUCTION LINE

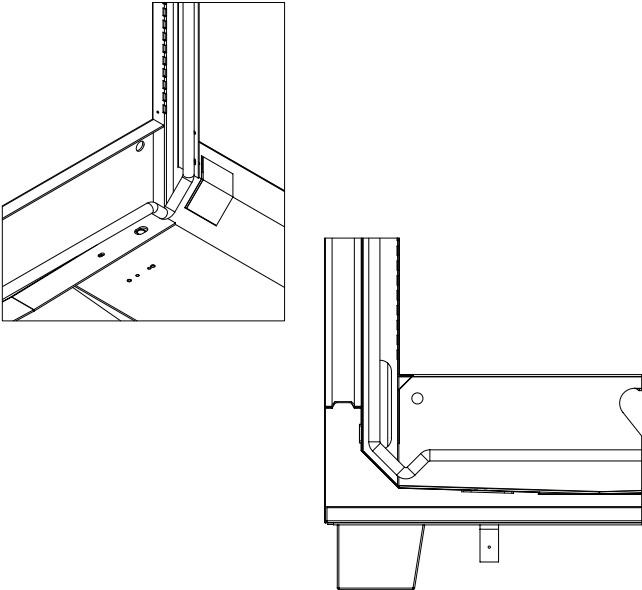

ILLUSTRATIONS

General

FIGURE 22: TEMPERATURE SETTINGS

FROZEN FOOD	ICE CREAM	MEDIUM TEMP
RACK SYSTEMS RHZC30 and RHZC30T Evaporator temp -7°F	RACK SYSTEMS RHZC30 and RHZC30T Evaporator temp -16°F	RACK SYSTEMS RHCC30 and RHCC30T Evaporator temp +28°F
		RHCC 24" DOOR Evaporator temp +25°F
CONDENSING UNIT RHZC30 and RHZC30T Cut-in pressure set to the dew point equivalent of 2°F for your refrigerant Cut-out pressure set to the dew point equivalent of -10°F for your refrigerant	CONDENSING UNIT RHZC30 and RHZC30T Cut-in pressure set to the dew point equivalent of -6°F for your refrigerant Cut-out pressure set to the dew point equivalent of -20°F for your refrigerant	CONDENSING UNIT RHCC30 and RHCC30T Cut-in pressure set to the dew point equivalent of 33°F for your refrigerant Cut-out pressure set to the dew point equivalent of 25°F for your refrigerant
		RHCC24 Cut-in / cut-out pressure set to the dew point equivalent of the refrigerant
RETURN & DISCHARGE AIR TEMPERATURE Return air temp cut-in +6°F Return air temp cut-out 0°F Discharge air temp cut-in +3°F Discharge air temp cut-out -3°F	RETURN & DISCHARGE AIR TEMPERATURE Return air temp cut-in -3°F Return air temp cut-out -9°F Discharge air temp cut-in 0°F Discharge air temp cut-out -12°F	RETURN & DISCHARGE AIR TEMPERATURE Return air temp cut-in 30°F Return air temp cut-out 34°F Discharge air temp cut-in 33°F Discharge air temp cut-out 37°F

Note: These set points may require optimization for your applications to prevent short or delayed cycling.

FIGURE 23: TEMPERATURE CONTROL

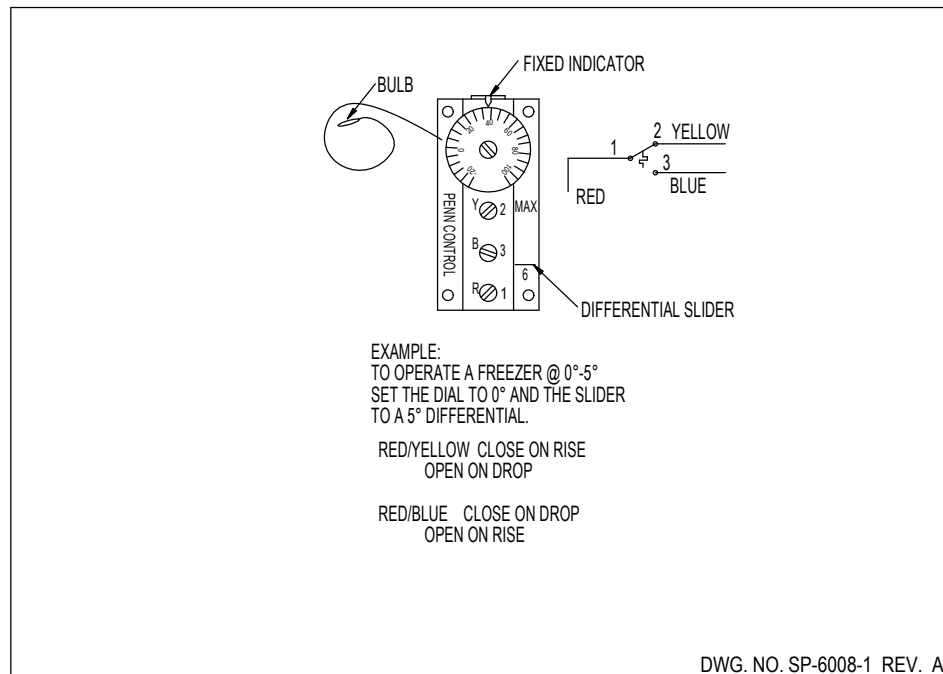

ILLUSTRATIONS

Refrigeration Line Sizing - Frozen Foods

FIGURE 24: LOW TEMP - FROZEN FOODS

R-404 Line Sizing Tables for Zero Zone Frozen Food Freezer (-7°F Evaporator Temperature)

Liquid Line Sizing - Electric Defrost*

Up to 50 equivalent feet

90°F Liquid, 2°F Pressure Drop[‡]

For rated Btuh:		
From	To	Liquid Line
0	7,300	1/4*
7,310	15,000	5/16 [†]
15,010	27,300	3/8
27,310	64,600	1/2
64,610	122,000	5/8

Up to 100 equivalent feet

90°F Liquid, 2°F Pressure Drop[‡]

For rated Btuh:		
From	To	Liquid Line
0	4,970	1/4*
4,980	10,300	5/16 [†]
10,310	18,700	3/8
18,710	44,300	1/2
44,310	83,200	5/8

Up to 150 equivalent feet

90°F Liquid, 2°F Pressure Drop[‡]

For rated Btuh:		
From	To	Liquid Line
0	3,960	1/4*
3,970	8,150	5/16 [†]
8,160	14,900	3/8
14,910	35,500	1/2
35,510	66,700	5/8
66,710	111,000	7/8 [†]

Up to 200 equivalent feet

90°F Liquid, 2°F Pressure Drop[‡]

For rated Btuh:		
From	To	Liquid Line
0	3,370	1/4*
3,380	6,940	5/16 [†]
6,950	12,700	3/8
12,710	30,300	1/2
30,310	56,900	5/8
56,910	94,800	7/8 [†]

* For hot gas defrost, use a liquid line one size larger than shown.

[‡] For 1°F pressure drop, multiply rated Btuh by 1.45 before using the Liquid Line Sizing Table.

[†] Larger liquid line size may be used (such as 3/8), if preferred.

[†] 3/4 liquid line may be used to reduce cost.

Liquid Correction Factors for Liquid Line Sizing Table - Use Maximum Liquid Temperature

For maximum liquid temperatures other than 90°F, multiply rated Btuh by liquid correction factor before using the Liquid Line Sizing Table

Maximum Liquid Temperature:	40°F	50°F	60°F	70°F	80°F	90°F	100°F	110°F	120°F
Liquid Correction Factor:	0.96	0.95	0.95	0.95	0.97	1.00	1.05	1.12	1.21

Suction Horizontal Line Sizing

Up to 50 equivalent feet

90°F Liquid, 2°F Pressure Drop[‡]

For rated Btuh:		
From	To	Horizontal
0	1,730	3/8**
1,740	4,100	1/2**
4,110	7,700	5/8**
7,710	12,800	7/8 [†]
12,810	20,300	7/8
20,310	41,000	1-1/8
41,010	71,400	1-3/8
71,410	113,000	1-5/8

Up to 100 equivalent feet

90°F Liquid, 2°F Pressure Drop[‡]

For rated Btuh:		
From	To	Horizontal
0	1,180	3/8**
1,190	2,810	1/2**
2,820	5,280	5/8**
5,290	8,780	7/8 [†]
8,790	14,000	7/8
14,010	28,200	1-1/8
28,210	49,200	1-3/8
49,210	77,800	1-5/8

Up to 150 equivalent feet

90°F Liquid, 2°F Pressure Drop[‡]

For rated Btuh:		
From	To	Horizontal
0	940	3/8**
950	2,240	1/2**
2,250	4,220	5/8**
4,230	7,030	7/8 [†]
7,040	11,200	7/8
11,210	22,700	1-1/8
22,710	39,500	1-3/8
39,510	62,500	1-5/8
62,510	130,000	2-1/8

Up to 200 equivalent feet

90°F Liquid, 2°F Pressure Drop[‡]

For rated Btuh:		
From	To	Horizontal
0	800	3/8**
810	1,910	1/2**
1,920	3,600	5/8**
3,610	6,000	7/8 [†]
6,010	9,530	7/8
9,540	19,400	1-1/8
19,410	33,800	1-3/8
33,810	53,500	1-5/8
53,510	112,000	2-1/8

[‡] For 1°F pressure drop, multiply rated BTU by 1.44 before using the Suction Horizontal Line Sizing Table.

** Larger suction horizontal line size may be used, if preferred.

[†] 3/4 horizontal suction line may be used to reduce cost.

Liquid Correction Factors for Suction Horizontal Line Sizing Table - Use Maximum Liquid Temperature

For maximum liquid temperatures other than 90°F, multiply rated Btuh by liquid correction factor before using the Suction Horizontal Line Sizing Table

Maximum Liquid Temperature:	40°F	50°F	60°F	70°F	80°F	90°F	100°F	110°F	120°F
Liquid Correction Factor:	0.72	0.76	0.81	0.86	0.92	1.00	1.09	1.21	1.37

Suction Vertical Riser Sizing

Maximum Allowable Riser Size For Adequate Oil Return*

70°F Minimum Liquid Temperature, using 0.35 PSI Per 100 Feet (per 2006 ASHRAE Handbook - Refrigeration).

For rated Btuh:		
From	To	Vertical
1,360	2,550	1/2
2,560	4,270	5/8
4,280	6,790	5/8 [†]
6,800	13,900	7/8
13,910	24,300	1-1/8
24,310	38,400	1-3/8
38,410	80,000	1-5/8
80,010	142,000	2-1/8

It may be necessary to make adjustments to compensate for special situations which cause the actual Btuh to differ from the rated Btuh of the cases.

All liquid line and suction line sizes are inches, refrigeration O.D. Subject to change without notice.

* If horizontal line size is smaller than specified vertical riser size, the smaller size may be used for both.

[†] 3/4 suction riser may be used to reduce pressure drop.

Liquid Correction Factors for Suction Vertical Riser Sizing Table - Use Minimum Liquid Temperature

Multiply rated Btuh by liquid correction factor before using the Suction Vertical Riser Sizing Table

Minimum Liquid Temperature:	40°F	50°F	60°F	70°F	80°F	90°F	100°F
Liquid Correction Factor:	0.84	0.88	0.94	1.00	1.07	1.16	1.27

CJ 3/8/17

SP-0612-01, Rev D

ILLUSTRATIONS

Refrigeration Line Sizing - Ice Cream

FIGURE 25: LOW TEMP - ICE CREAM

R-404 Line Sizing Tables for Zero Zone Ice Cream Freezer (-16°F Evaporator Temperature)

Liquid Line Sizing - Electric Defrost*

Up to 50 equivalent feet

90°F Liquid, 2°F Pressure Drop[‡]

For rated Btuh:		
From	To	Liquid Line
0	7,090	1/4 [†]
7,100	14,600	5/16 [*]
14,610	26,500	3/8
26,510	62,800	1/2
62,810	117,000	5/8

Up to 100 equivalent feet

90°F Liquid, 2°F Pressure Drop[‡]

For rated Btuh:		
From	To	Liquid Line
0	4,830	1/4 [†]
4,840	9,930	5/16 [*]
9,940	18,200	3/8
18,210	43,100	1/2
43,110	80,900	5/8

Up to 150 equivalent feet

90°F Liquid, 2°F Pressure Drop[‡]

For rated Btuh:		
From	To	Liquid Line
0	3,850	1/4 [†]
3,860	7,930	5/16 [*]
7,940	14,500	3/8
14,510	34,500	1/2
34,510	64,800	5/8
64,810	108,000	7/8 [†]

Up to 200 equivalent feet

90°F Liquid, 2°F Pressure Drop[‡]

For rated Btuh:		
From	To	Liquid Line
0	3,270	1/4 [†]
3,280	6,750	5/16 [*]
6,760	12,400	3/8
12,410	29,400	1/2
29,410	55,400	5/8
55,410	92,100	7/8 [†]

* For hot gas defrost, use a liquid line one size larger than shown.

‡ For 1°F pressure drop, multiply rated Btuh by 1.45 before using the Liquid Line Sizing Table.

† Larger liquid line size may be used (such as 3/8), if preferred.

‡ 3/4 liquid line may be used to reduce cost.

Liquid Correction Factors for Liquid Line Sizing Table - Use Maximum Liquid Temperature

For maximum liquid temperatures other than 90°F, multiply rated Btuh by liquid correction factor before using the Liquid Line Sizing Table

Maximum Liquid Temperature:	40°F	50°F	60°F	70°F	80°F	90°F	100°F	110°F	120°F
Liquid Correction Factor:	0.95	0.94	0.94	0.95	0.97	1.00	1.05	1.12	1.23

Suction Horizontal Line Sizing

Up to 50 equivalent feet

90°F Liquid, 2°F Pressure Drop[‡]

For rated Btuh:		
From	To	Horizontal
0	1,420	3/8 ^{**}
1,430	3,360	1/2 ^{**}
3,370	6,300	5/8 ^{**}
6,310	10,500	7/8 [†]
10,510	16,600	7/8
16,610	33,600	1-1/8
33,610	58,400	1-3/8
58,410	92,300	1-5/8

Up to 100 equivalent feet

90°F Liquid, 2°F Pressure Drop[‡]

For rated Btuh:		
From	To	Horizontal
0	970	3/8 ^{**}
980	2,290	1/2 ^{**}
2,300	4,320	5/8 ^{**}
4,330	7,180	7/8 [†]
7,190	11,400	7/8
11,410	23,100	1-1/8
23,110	40,300	1-3/8
40,310	63,700	1-5/8
63,710	132,000	2-1/8

Up to 150 equivalent feet

90°F Liquid, 2°F Pressure Drop[‡]

For rated Btuh:		
From	To	Horizontal
0	770	3/8 ^{**}
780	1,840	1/2 ^{**}
1,850	3,450	5/8 ^{**}
3,460	5,750	7/8 [†]
5,760	9,120	7/8
9,130	18,600	1-1/8
18,610	32,400	1-3/8
32,410	51,200	1-5/8
51,210	107,000	2-1/8

Up to 200 equivalent feet

90°F Liquid, 2°F Pressure Drop[‡]

For rated Btuh:		
From	To	Horizontal
0	660	3/8 ^{**}
670	1,560	1/2 ^{**}
1,570	2,950	5/8 ^{**}
2,960	4,910	7/8 [†]
4,920	7,790	7/8
7,800	15,900	1-1/8
15,910	27,700	1-3/8
27,710	43,800	1-5/8
43,810	91,000	2-1/8

‡ For 1°F pressure drop, multiply rated BTU by 1.44 before using the Suction Horizontal Line Sizing Table.

** Larger suction horizontal line size may be used, if preferred.

† 3/4 horizontal suction line may be used to reduce cost.

Liquid Correction Factors for Suction Horizontal Line Sizing Table - Use Maximum Liquid Temperature

For maximum liquid temperatures other than 90°F, multiply rated Btuh by liquid correction factor before using the Suction Horizontal Line Sizing Table

Maximum Liquid Temperature:	40°F	50°F	60°F	70°F	80°F	90°F	100°F	110°F	120°F
Liquid Correction Factor:	0.72	0.76	0.80	0.86	0.92	1.00	1.10	1.22	1.38

Suction Vertical Riser Sizing

Maximum Allowable Riser Size For Adequate Oil Return*

70°F Minimum Liquid Temperature, using 0.35 PSI Per 100 Feet (per 2006 ASHRAE Handbook - Refrigeration).

For rated Btuh:		
From	To	Vertical
1,210	2,280	1/2
2,290	3,810	5/8
3,820	6,050	5/8 [†]
6,060	12,400	7/8
12,410	21,600	1-1/8
21,610	34,300	1-3/8
34,310	71,300	1-5/8
71,310	127,000	2-1/8

* If horizontal line size is smaller than specified vertical riser size, the smaller size may be used for both.

† 3/4 suction riser may be used to reduce pressure drop.

Liquid Correction Factors for Suction Vertical Riser Sizing Table - Use Minimum Liquid Temperature

Multiply rated Btuh by liquid correction factor before using the Suction Vertical Riser Sizing Table

Minimum Liquid Temperature:	40°F	50°F	60°F	70°F	80°F	90°F	100°F
Liquid Correction Factor:	0.83	0.88	0.94	1.00	1.08	1.17	1.28

CAJ 3/8/17

SP-0612-02, Rev D

It may be necessary to make adjustments to compensate for special situations which cause the actual Btuh to differ from the rated Btuh of the cases.

All liquid line and suction line sizes are inches, refrigeration O.D.
Subject to change without notice.

ILLUSTRATIONS

Refrigeration Line Sizing

FIGURE 26: REFRIGERATION LINE SIZING

R-404 Line Sizing Tables for Zero Zone Cooler (+28°F Evaporator Temperature)

Liquid Line Sizing

Up to 50 equivalent feet

90°F Liquid, 2°F Pressure Drop[‡]

For rated Btuh:		
From	To	Liquid Line
0	2,750	3/16"
2,760	8,050	1/4"
8,060	16,600	5/16"
16,610	30,100	3/8
30,110	71,200	1/2

Up to 100 equivalent feet

90°F Liquid, 2°F Pressure Drop[‡]

For rated Btuh:		
From	To	Liquid Line
0	1,870	3/16"
1,880	5,480	1/4"
5,490	11,300	5/16"
11,310	20,600	3/8
20,610	48,800	1/2
48,810	91,700	5/8

Up to 150 equivalent feet

90°F Liquid, 2°F Pressure Drop[‡]

For rated Btuh:		
From	To	Liquid Line
0	1,480	3/16"
1,490	4,360	1/4"
4,370	8,990	5/16"
9,000	16,500	3/8
16,510	39,100	1/2
39,110	73,500	5/8

Up to 200 equivalent feet

90°F Liquid, 2°F Pressure Drop[‡]

For rated Btuh:		
From	To	Liquid Line
0	1,260	3/16"
1,270	3,710	1/4"
3,720	7,660	5/16"
7,670	14,000	3/8
14,010	33,400	1/2
33,410	62,800	5/8

[‡] For 1°F pressure drop, multiply rated Btuh by 1.45 before using the Liquid Line Sizing Table.

[†] Larger liquid line size may be used (such as 3/8), if preferred.

Liquid Correction Factors for Liquid Line Sizing Table - Use Maximum Liquid Temperature

For maximum liquid temperatures other than 90°F, multiply rated Btuh by liquid correction factor before using the Liquid Line Sizing Table

Maximum Liquid Temperature:	40°F	50°F	60°F	70°F	80°F	90°F	100°F	110°F	120°F
Liquid Correction Factor:	0.98	0.97	0.96	0.97	0.98	1.00	1.04	1.09	1.17

Suction Horizontal Line Sizing

Up to 50 equivalent feet

90°F Liquid, 2°F Pressure Drop[‡]

For rated Btuh:		
From	To	Horizontal
0	1,970	5/16"
1,980	3,580	3/8
3,590	8,460	1/2
8,470	15,900	5/8
15,910	26,300	7/8 [†]
26,310	41,600	7/8
41,610	84,000	1-1/8

Up to 100 equivalent feet

90°F Liquid, 2°F Pressure Drop[‡]

For rated Btuh:		
From	To	Horizontal
0	1,350	5/16"
1,360	2,450	3/8
2,460	5,810	1/2
5,820	10,900	5/8
10,910	18,100	7/8 [†]
18,110	28,700	7/8
28,710	58,000	1-1/8

Up to 150 equivalent feet

90°F Liquid, 2°F Pressure Drop[‡]

For rated Btuh:		
From	To	Horizontal
0	1,080	5/16"
1,090	1,960	3/8
1,970	4,650	1/2
4,660	8,740	5/8
8,750	14,600	7/8 [†]
14,610	23,100	7/8
23,110	46,700	1-1/8
46,710	81,300	1-3/8

Up to 200 equivalent feet

90°F Liquid, 2°F Pressure Drop[‡]

For rated Btuh:		
From	To	Horizontal
0	920	5/16"
930	1,670	3/8
1,680	3,970	1/2
3,980	7,470	5/8
7,480	12,500	7/8 [†]
12,510	19,700	7/8
19,710	40,000	1-1/8
40,010	69,600	1-3/8

[‡] For 1°F pressure drop, multiply rated Btuh by 1.44 before using the Suction Horizontal Line Sizing Table.

^{**} Larger suction horizontal line size may be used, if preferred.

[†] 3/4 horizontal suction line may be used to reduce cost.

Liquid Correction Factors for Suction Horizontal Line Sizing Table - Use Maximum Liquid Temperature

For maximum liquid temperatures other than 90°F, multiply rated Btuh by liquid correction factor before using the Suction Horizontal Line Sizing Table

Maximum Liquid Temperature:	40°F	50°F	60°F	70°F	80°F	90°F	100°F	110°F	120°F
Liquid Correction Factor:	0.74	0.78	0.82	0.87	0.93	1.00	1.08	1.19	1.32

Suction Vertical Riser Sizing

Maximum Allowable Riser Size For Adequate Oil Return*

70°F Minimum Liquid Temperature, using 0.35 PSI Per 100 Feet (per 2006 ASHRAE Handbook - Refrigeration)

For rated Btuh:		
From	To	Vertical
480	880	5/16
890	2,090	3/8
2,100	3,950	1/2
3,960	6,590	5/8
6,600	10,500	5/8 [†]
10,510	21,300	7/8
21,310	37,300	1-1/8
37,310	59,100	1-3/8

It may be necessary to make adjustments to compensate for special situations which cause the actual Btuh to differ from the rated Btuh of the cases.

All liquid line and suction line sizes are inches, refrigeration O.D. Subject to change without notice.

* If horizontal line size is smaller than specified vertical riser size, the smaller size may be used for both.

[†] 3/4 suction riser may be used to reduce pressure drop.

Liquid Correction Factors for Suction Vertical Riser Sizing Table - Use Minimum Liquid Temperature

Multiply rated Btuh by liquid correction factor before using the Suction Vertical Riser Sizing Table

Minimum Liquid Temperature:	40°F	50°F	60°F	70°F	80°F	90°F	100°F
Liquid Correction Factor:	0.85	0.89	0.94	1.00	1.07	1.15	1.24

CAJ 3/8/17

SP-0612-11, Rev C

ILLUSTRATIONS

Electric Defrost Wiring

FIGURE 27: LOW TEMP

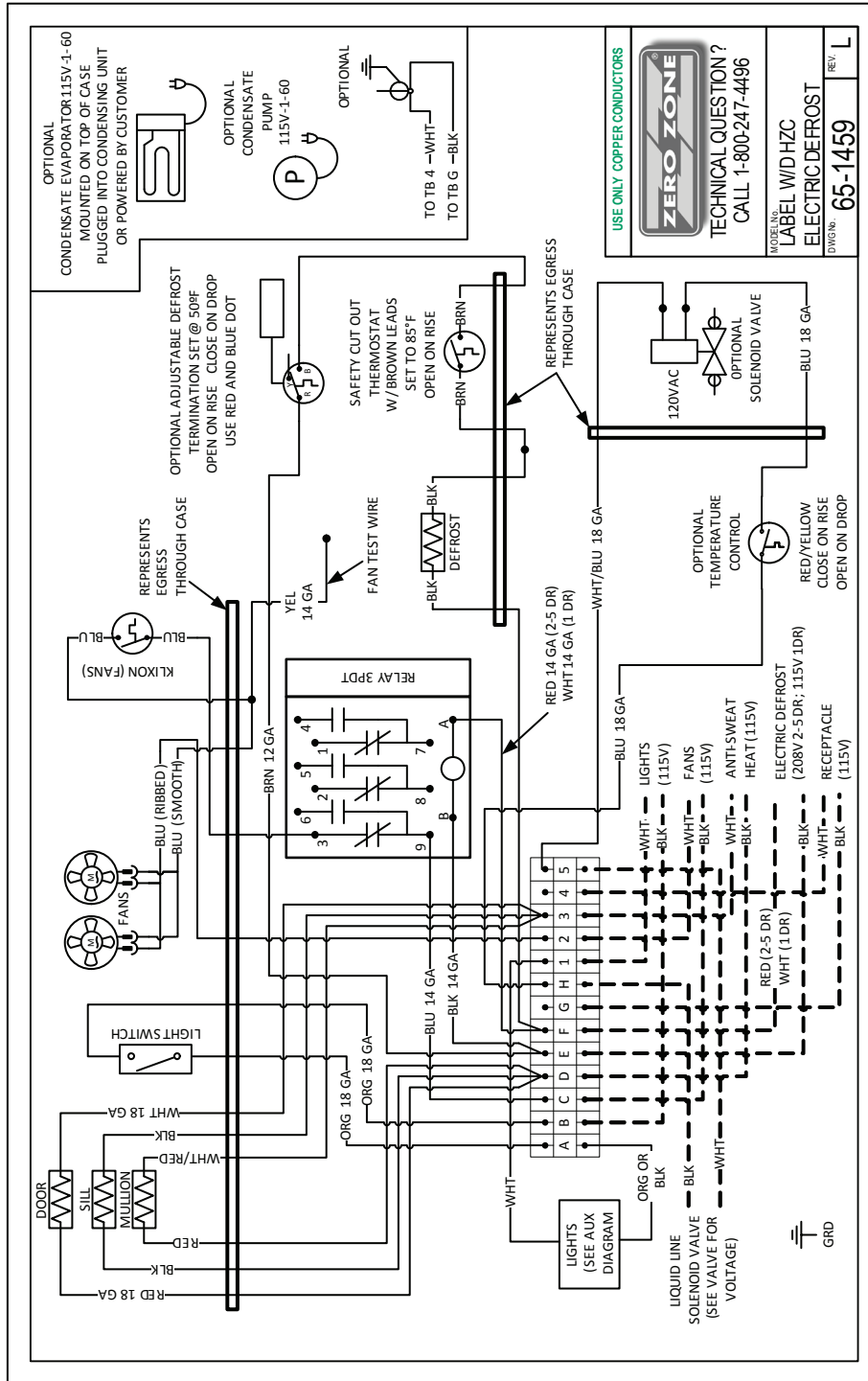

USE ONLY COPPER CONDUCTORS

ZERO ZONE

TECHNICAL QUESTION ?
CALL 1-800-247-4496

MODEL: LABEL W/D HZC
ELECTRIC DEFROST
DWG NO: **65-1459**
REV: **L**

LIGHTS (SEE AUX DIAGRAM)

LIGHTS (SEE AUX DIAGRAM)

LIGHTS (SEE AUX DIAGRAM)

LIQUID LINE

SOLENOID VALVE (SEE VALVE FOR VOLTAGE)

WHT - 115V

BLK - 115V

WHT - 115V

BLK - 115V

WHT - 115V

BLK - 115V

WHT - 115V

BLK - 115V

WHT - 115V

BLK - 115V

WHT - 115V

BLK - 115V

WHT - 115V

BLK - 115V

WHT - 115V

BLK - 115V

RED (2.5 DR)

WHT (1 DR)

BLK - 115V

WHT - 115V

BLK - 115V

GRD

ILLUSTRATIONS

Hot Gas Defrost Wiring

FIGURE 28: LOW TEMP

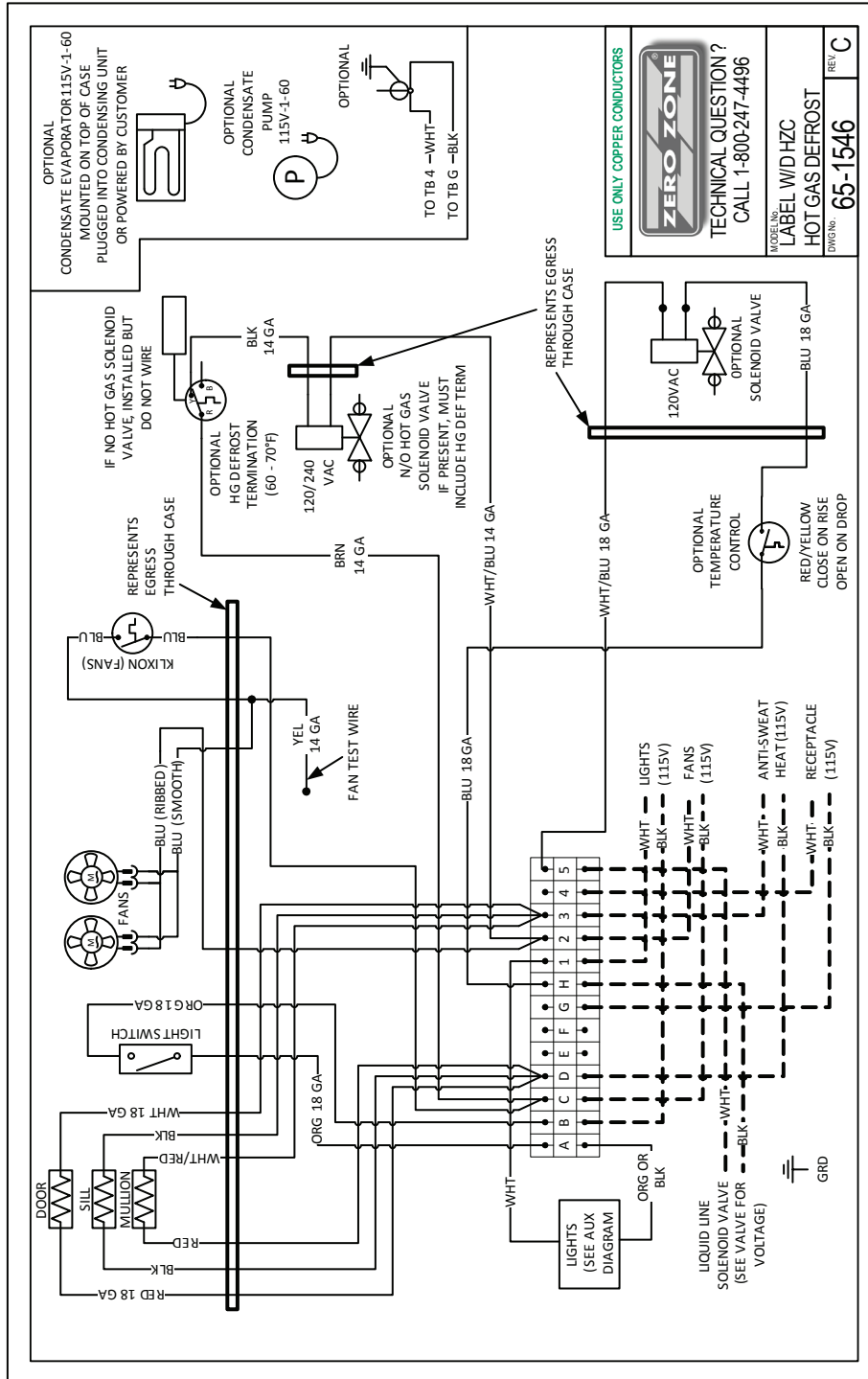

ILLUSTRATIONS

Single Point Connection Wiring

FIGURE 29: LOW TEMP

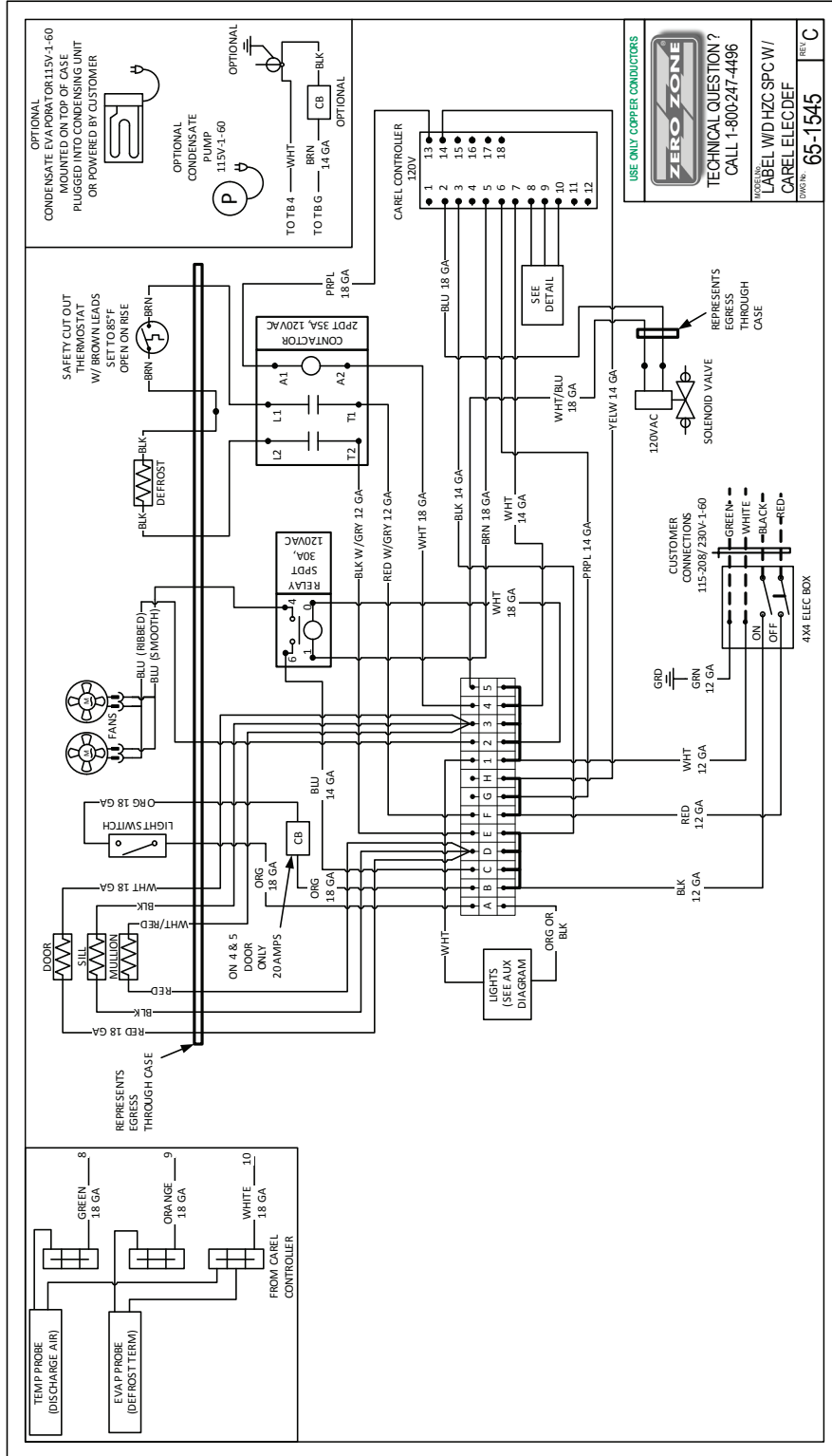

ILLUSTRATIONS

Master/Satellite Wiring

FIGURE 30: LOW TEMP

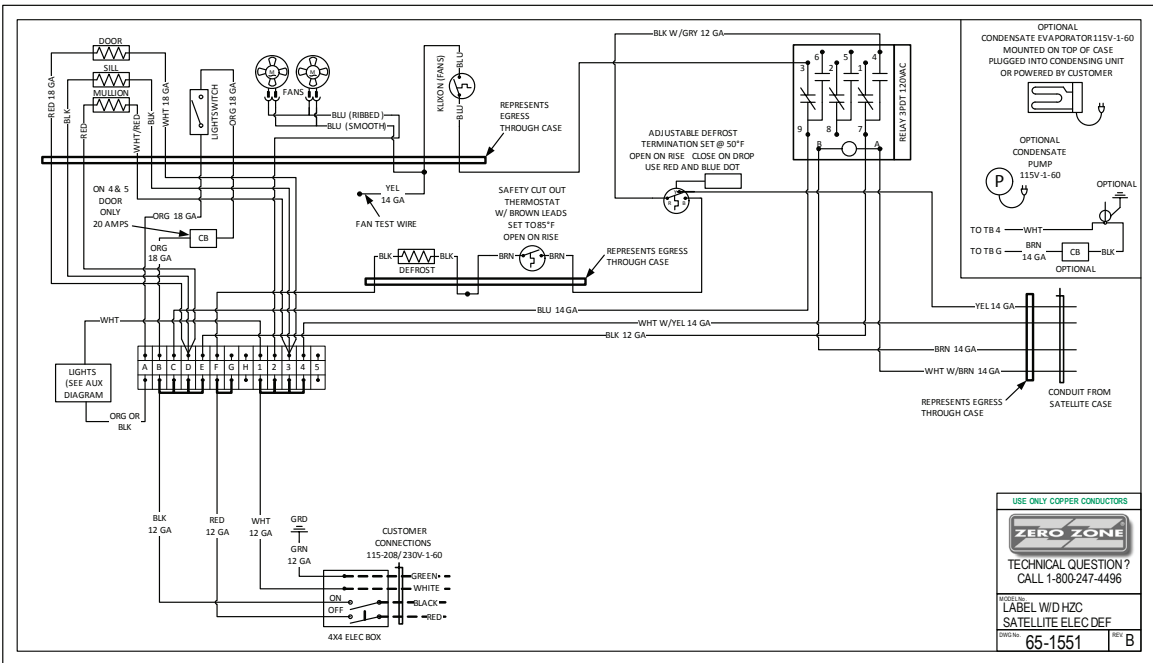
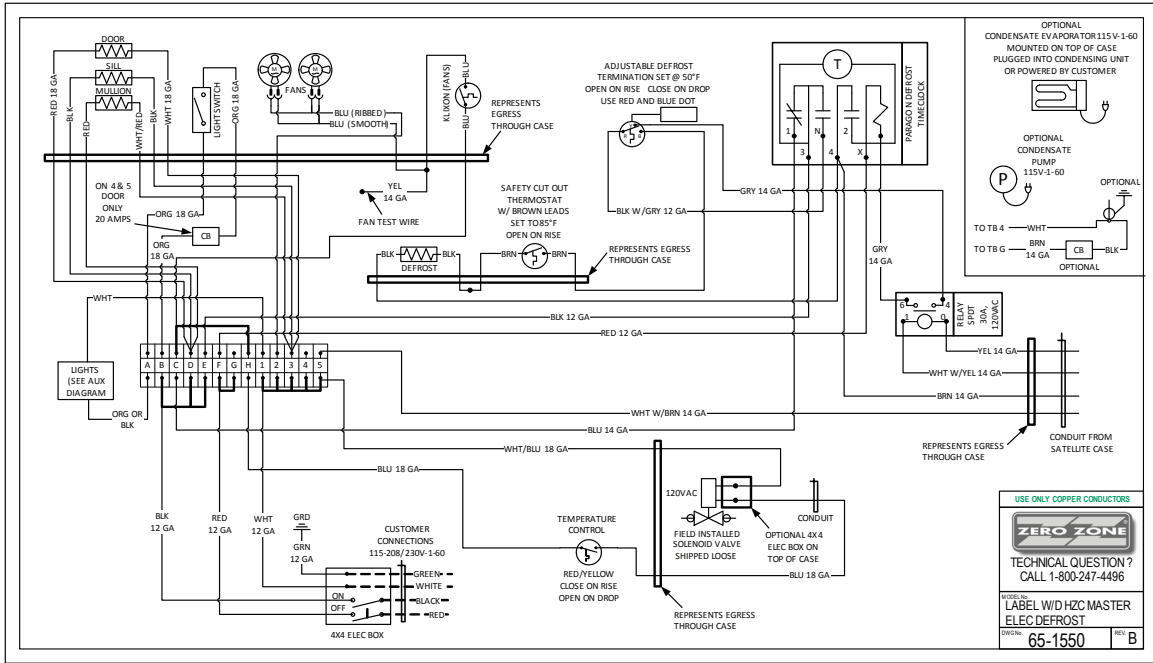

ILLUSTRATIONS

Off-Cycle Defrost or Satellite Wiring

FIGURE 31: MEDIUM TEMP

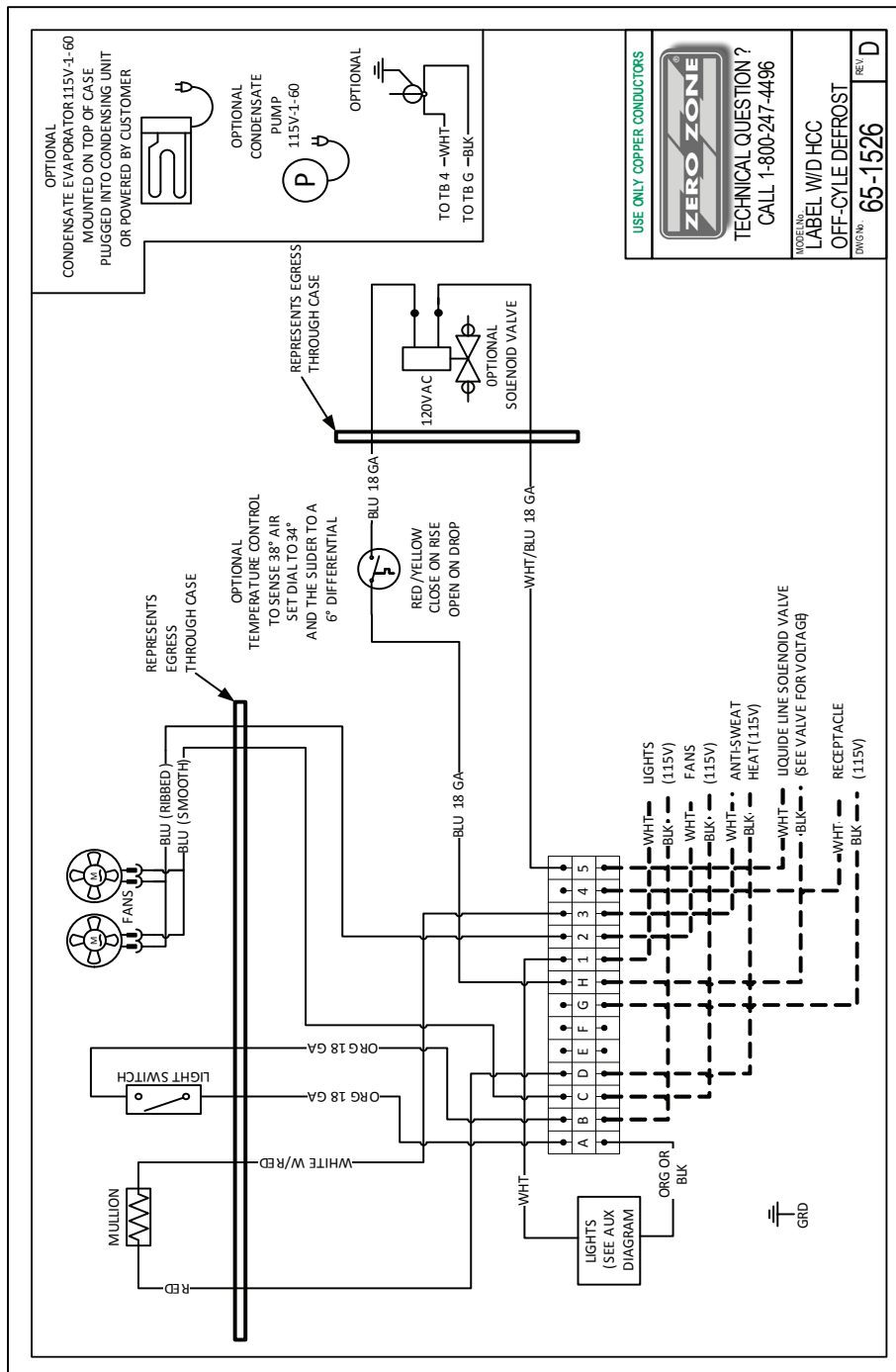

ILLUSTRATIONS

Single Point Connection or Master Wiring - Medium Temp

FIGURE 32: SINGLE POINT CONNECTION OR MASTER WIRING

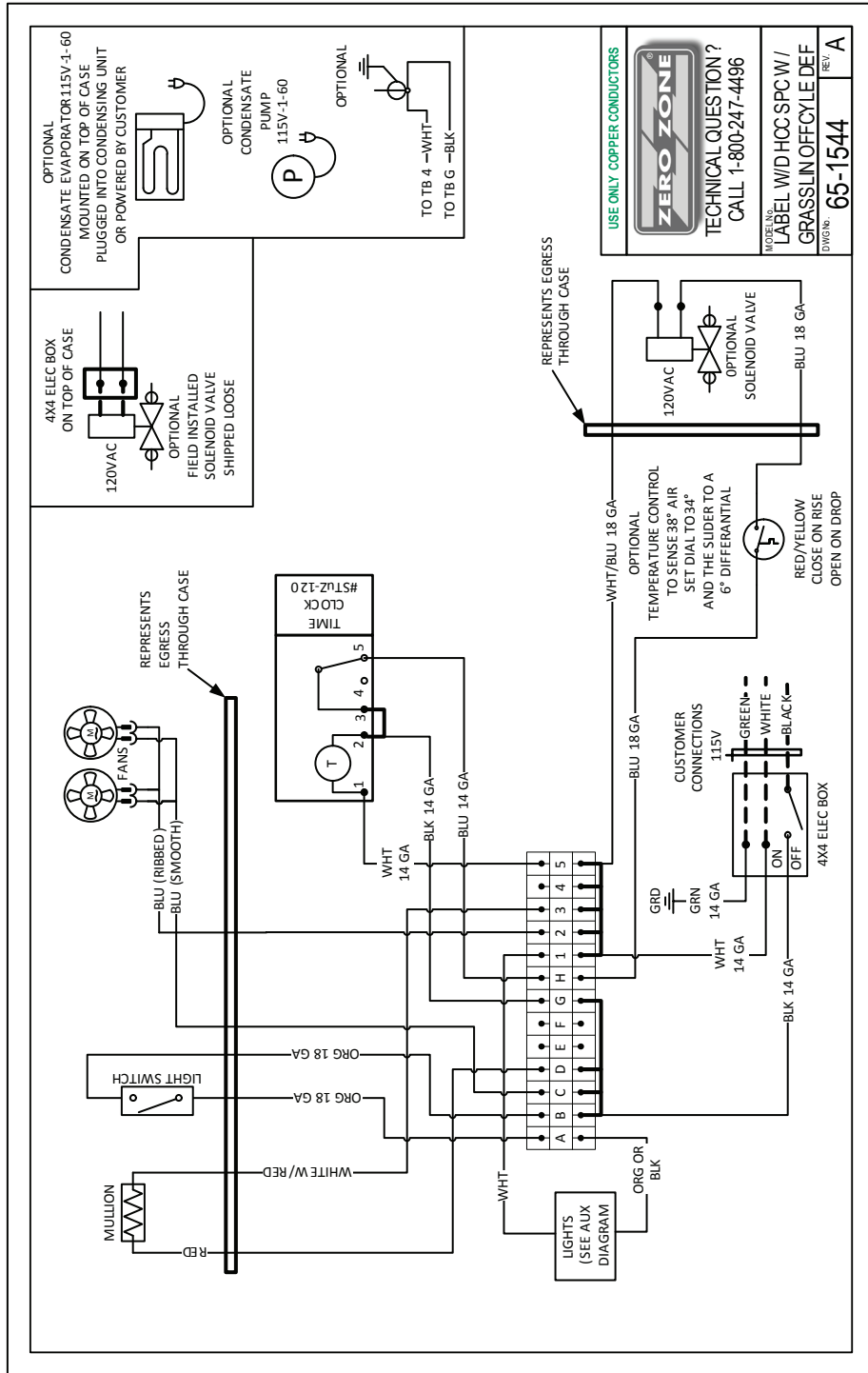

ILLUSTRATIONS

Hot Gas Defrost - Low Temp

ITEM #	PART NAME
1	COIL COVER
2	FAN
3	FAN HOUSING
4	COIL
5	CHECK VALVE
6	SERPENTINE
7	SLHX HEAT EXCHANGER
8	TXV VALVE
9	HAND VALVE (OPTIONAL)
10	DRIER (OPTIONAL)
11	CHECK VALVE
12	OPTIONAL DEFROST TERMINATION SOLENOID
13	HOT GAS CLIP
14	DEFROST TERMINATION PROBE LOCATION ON DUMP LINE

FIGURE 33: COIL 30" HOT GAS

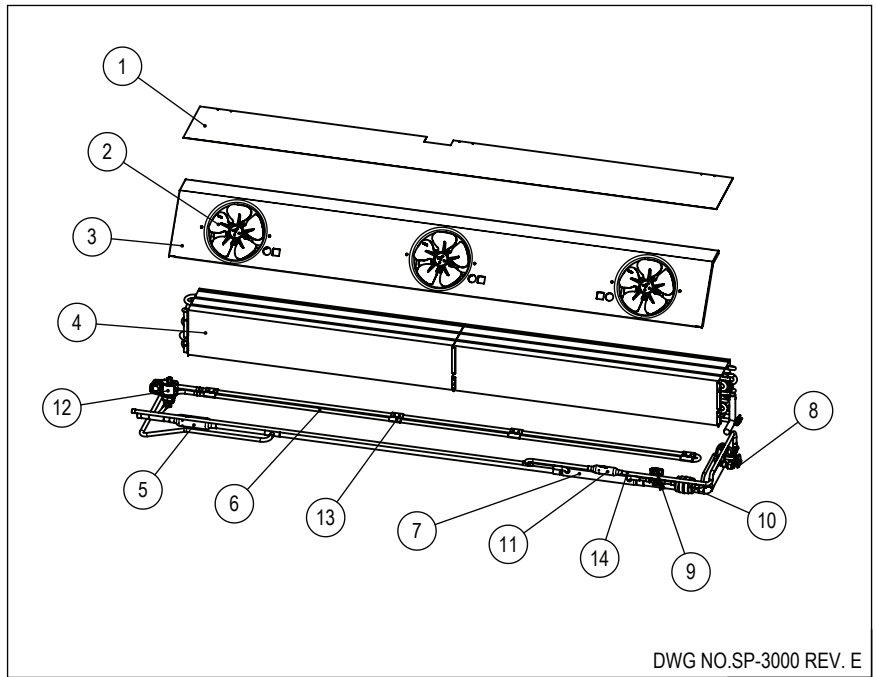

ILLUSTRATIONS

Electric Defrost - Low/Medium Temp

FIGURE 34: 30" ELECTRIC

ITEM #	PART NAME
1	COIL COVER
2	FAN
3	LIQUID LINE
4	SUCTION LINE
5	FAN HOUSING
6	HEAT EXCHANGER
7	EXPANSION VALVE
*8	HEATING ELEMENT
*9	HEATER CLIP
10	DEFROST TERMINATION PROBE LOCATION

*Low Temp Only

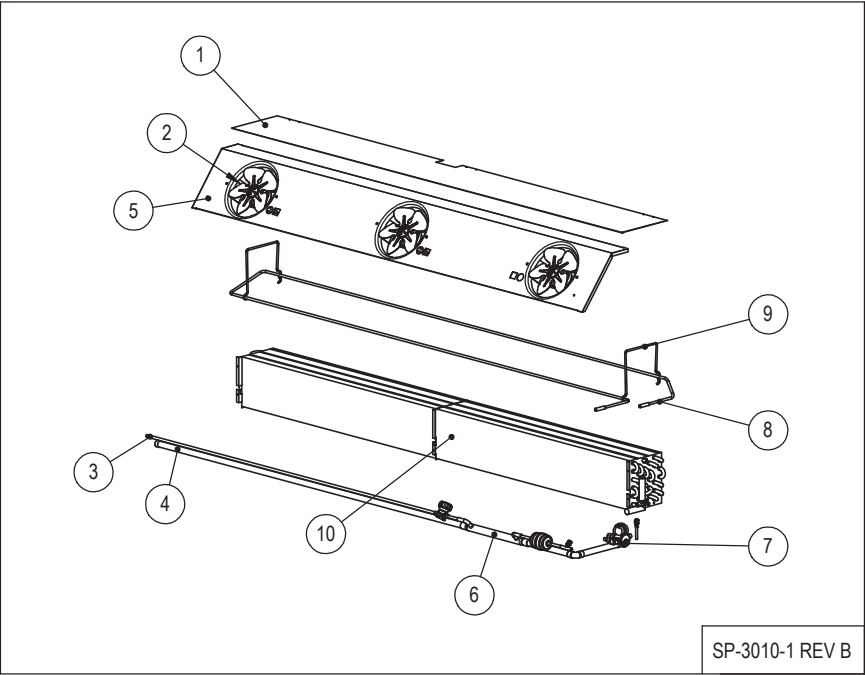

SP-3010-1 REV B



For other technical support, please refer to
the Technical Resources page at:

WWW.ZERO-ZONE.COM

or contact the Zero Zone Service Department at:

800-247-4496

All specifications subject to change without notice.

