



OMC SPECIFICATION SHEET

Open Multideck Mobile Merchandiser

Features and Benefits:

- Patented case design holds food products at Food Code required temperatures below 41° without freezing rear product by distributing coldest air to air curtain.
- Twin thermal pane glass front and side panels provide increased product visibility, easy cleanability and reduced heat gain.
- 100% CFC-free urethane foam and steel construction for maximum energy efficiency and product durability.
- Condensate pan evaporates accumulated water and eliminates the need for a floor drain.
- T-8 bulbs are energy efficient and provide brilliant sign and product display.

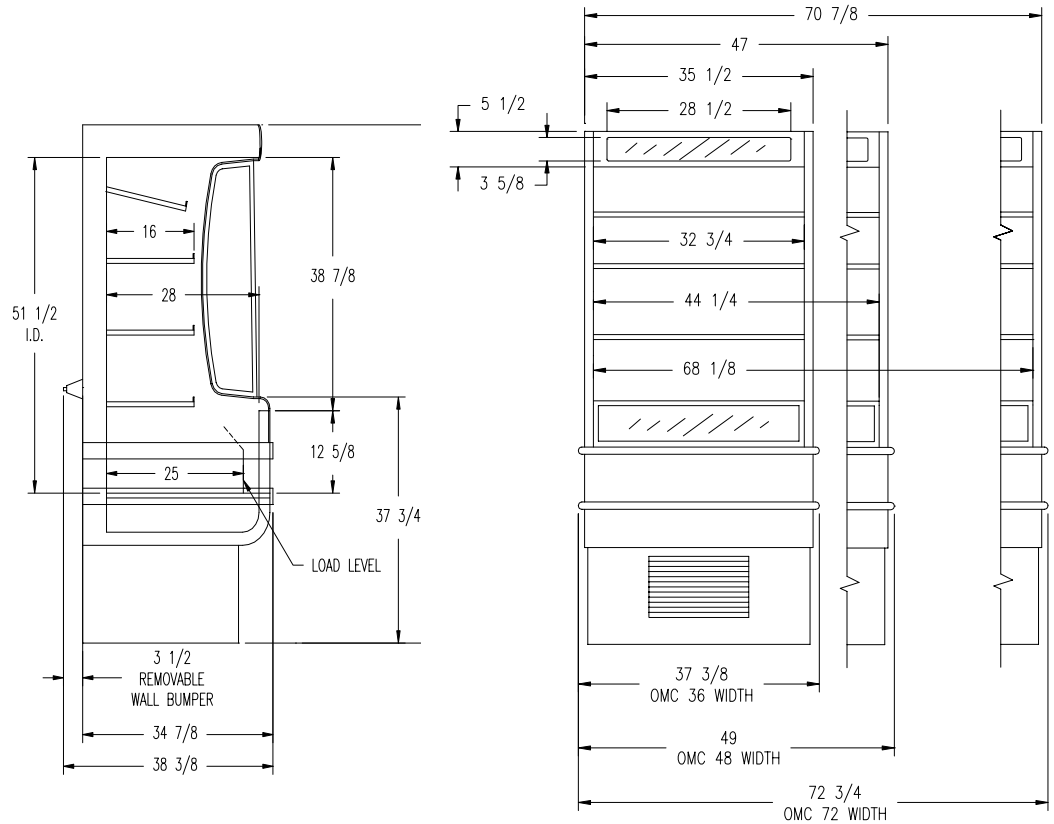

OMC48 208V
NEMA L14-20P PLUG



OMC36
OMC48
NEMA 5-30P PLUG



OMC72
NEMA L14-30P PLUG



NEMA L14-30P

Standard Features:

- White interior and exterior
- 1" Black bumpers on front and side of case
- Case wall bumpers
- White backlit sign face with black block letters
- R-404A
- Electronic Controller
- Standard commercial grade casters
- Four white solid shelves-two position
- 1-1/4" High product stops

Optional Features:

- Custom painted or vinyl laminate exterior.
- Custom painted interior and/or shelving
- Custom graphics on backlit sign face
- Additional shelving
- Custom bumper colors
- Price tag molding

| Model | Weight w/shelves pounds | ELECTRICAL | | | H.P. | Refrig. | Cubic Feet Capacity |
|--------|-------------------------|---------------------------|------------------|----------|------|---------|---------------------|
| | | Incoming Supply | Min Circuit Amps | AMPS RLA | | | |
| OMC 36 | 547 | 115V-1 PHASE -60 HZ | 30 | 19.6 | 3/4 | R-404A | 18 |
| OMC 48 | 657 | 115V-1 PHASE -60 HZ | 30 | 21.6 | 1 | R-404A | 24 |
| | | 208V-1 PHASE -60 HZ | 20 | 13.9 | 1 | | |
| OMC 72 | 740 | 208/230-115V-1 PHASE-60HZ | 30 | 19.0 | 2 | R-404A | 37 |

Case designed to operate in an ambient air temperature of 75°F or lower and relative humidity of 55% or lower.

All specifications are subject to change without notice.



Zero Zone, Inc. 110 N Oakridge Dr. North Prairie, WI 53153-9792
(800) 247-4496 fax (262) 392-6450
www.zero-zone.com

