

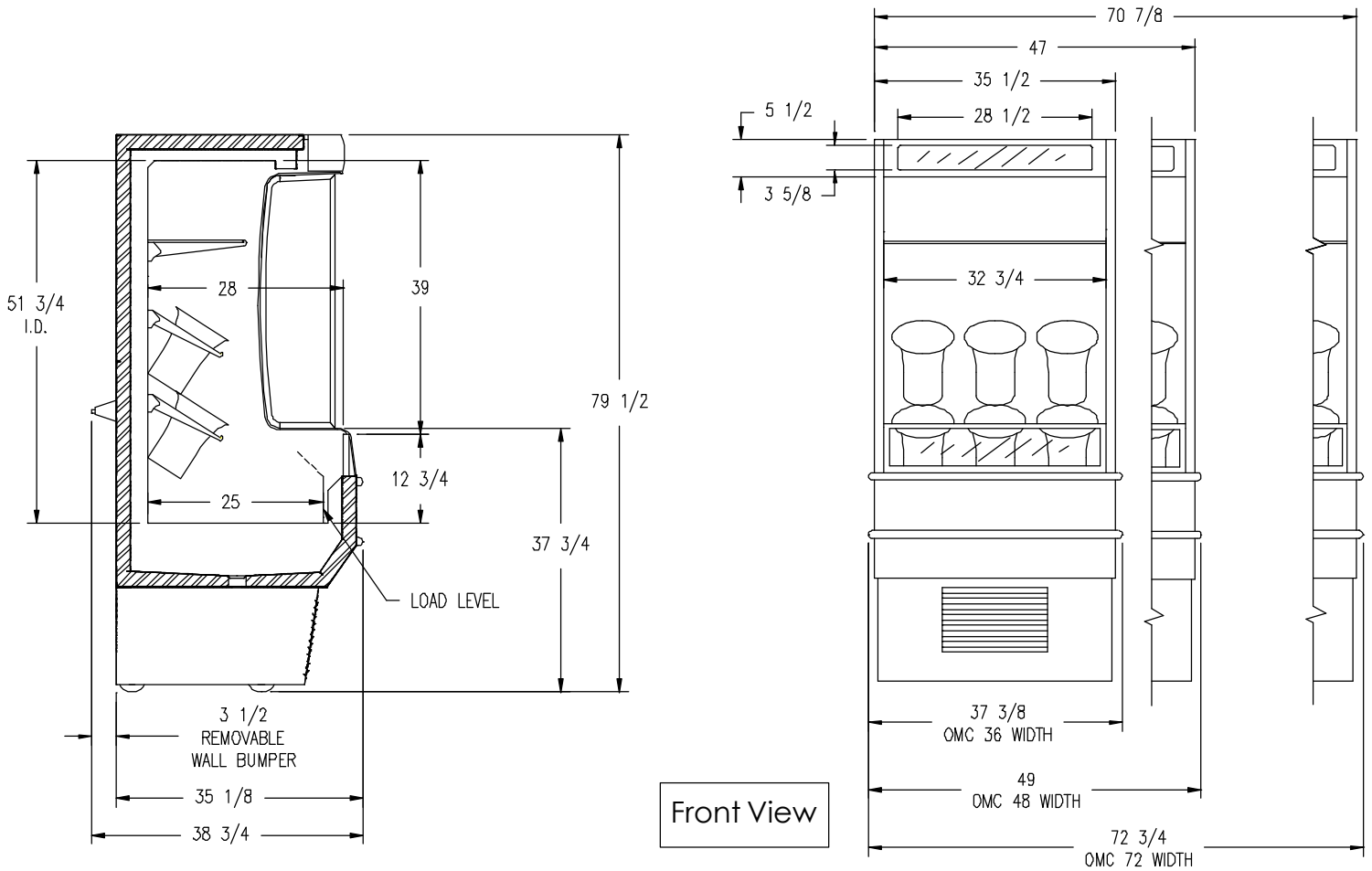

# OMCFL SPECIFICATION SHEET



MODEL	ESTIMATED WEIGHT	OUTSIDE DIMENSIONS (INCHES)			INSIDE DIMENSIONS (INCHES)			CUBIC FEET CAPACITY
		W	H	D	W	H	D	
OMC36FL	547	37-3/8	79-1/2	38-3/4	32-3/4	51-3/4	25	18
OMC48FL	657	49	79 1/2	38 3/4	44 1/4	51 3/4	25	24
OMC72FL	740	72-3/4	79 1/2	38 3/4	68-1/8"	51 3/4	25	37

MODEL	ELECTRICAL			H.P.	REFRIG.
	INCOMING SUPPLY	MIN CIRCUIT AMPS	AMPS RLA		
OMC36FL	115-1 PHASE - 60 HZ	30	19.6	3/4	R-404A
OMC48FL	115-1 PHASE - 60 HZ	30	21.6	1	R-404A
OMC72FL	208/230 - 115 - 1 PHASE - 60 HZ	30	19.0	(2) 3/4	R-404A

CASE DESIGNED TO OPERATE IN AN AMBIENT OF 75°F OR LOWER AND RELATIVE HUMIDITY OF 55% OR LOWER

Zero Zone, Inc. • 110 N. Oakridge Dr.  
 North Prairie, WI 53153-9792  
 1-800-247-4496 • FAX: 1-262-392-6450  
 www.zero-zone.com



All specifications are subject to change without notice.