



Refrigeration Data

Refrigeration	Lineup Data	Individual Case Data (Includes 1 Pair of End Panels)			
	Per Foot Avg.	4'	6'	8'	12'
Evaporator Temperature (°F) ^{1,2}	28	28	28	28	28
Baseline Btu/h ^{3,4}	1,270	5,566	8,189	10,704	15,735
Discharge Air Temperature (°F) (w/ 8°F Superheat) ⁵	37	37	37	37	37
Discharge Air Velocity (fpm) ⁶	230	230	230	230	230
Btu/h Deducts	Btu/h Per Foot	Btu/h	Btu/h	Btu/h	Btu/h
Low Sill with Glass Front	-100	-400	-600	-800	-1,200
Medium Sill	-40	-160	-240	-320	-480
Medium Sill with Glass Front	-140	-560	-840	-1,120	-1,680
Btu/h Adders	Btu/h Per Foot	Btu/h	Btu/h	Btu/h	Btu/h
Canopy LED Lights (Zero Zone ChillBrite 4249) 2nd Row	13	52	78	104	156
Sill LED Lights (Zero Zone ChillBrite 4251) 1 Row	7	28	42	56	84
Undershelf LED Lights (Zero Zone ChillBrite 4250) Per Row	10	40	60	80	120

Electrical & Energy Data ⁷

Fan Motors (115V)	Lineup Data		Individual Case Data (Includes 1 Pair of End Panels)							
	Amps	Watts	4'		6'		8'		12'	
High Efficiency Electronic (ECM or SSC)	0.11	7.7	0.60	42	0.60	42	0.90	63	1.20	84
Lighting System (115V)	Amps	Watts	Amps	Watts	Amps	Watts	Amps	Watts	Amps	Watts
Canopy LED Lights (Zero Zone ChillBrite 4249) Per Row	0.047	5.8	0.19	23	0.28	35	0.38	46	0.56	69
Sill LED Lights (Zero Zone ChillBrite 4251) 1 Row	0.023	2.9	0.09	12	0.14	17	0.19	23	0.28	35
Undershelf LED Lights (Zero Zone ChillBrite 4250) Per Row	0.012	1.5	0.05	6	0.07	9	0.10	12	0.14	17

Physical Data

Refrigeration Piping: R-404A & R-448A ⁸	Outlet Size (in.)					
	4'	6'	8'	12'		
Suction Line O.D. (Top Refrigeration Exit)	5/8	5/8	7/8	7/8		
Liquid Line O.D.	3/8	3/8	3/8	3/8		
Refrigeration Piping: CO2 ⁸	4'	6'	8'	12'		
Suction Line O.D. (Top Refrigeration Exit)	1/2	1/2	1/2	1/2		
Liquid Line O.D.	3/8	3/8	1/2	1/2		
Case Calculations	Solid End Panel	Windowed End ⁹	4'	6'	8'	12'
Weight (lbs.)	30	50	452	678	791	1,222

Operating Set Points

Off-Cycle Defrost	R-404A	R-448A
Time Per Defrost (Minutes)	36	30
Drip Time (Minutes)	N/A	N/A
EPR Settings (psig)	66	59
Frequency (Per Day)	4	6

Notes:

- For high-glide refrigerants, use dew point for unit sizing. Adjust evaporator pressure as needed to maintain discharge air temperatures.
- Evaporator temperatures listed above are for unlit shelves. Evaporator temperatures may need to be reduced for lit shelves or aftermarket display accessories.
- Baseline Evaporator Btu/h based on parallel rack system, 1 row LED canopy lighting (Zero Zone ChillBrite®), ECM or SSC electronic fan motors, 4 rows of angled and tiered shelves, and low sill height.
- For condensing units (non-rack system), multiply total Btu/h rating by 1.11 (R-404A) or 1.14 (R-448A).
- Discharge air temperature is measured at the outlet of the honeycomb.
- Discharge air velocity is average velocity at peak of defrost.

- Amps are based on electrical nameplate values. Watts are based on laboratory observations of actual energy use.
- Use 0.5 lb/ft evaporator refrigerant charge for receiver sizing.
- Glass windowed end panels only available with 2 1/2" end panels.

Case Performance Notes:

- Btu/h load increases by approximately 120 Btu/h per foot for aftermarket shelving/merchandising.
- Operating temperature and defrost set points may need to be adjusted for alternate shelving, store conditions, or packout.
- A minimum 20° evaporator is recommended without positive defrost.



Reveal Merchandiser® ORMC80(L/M)-PX Specs

Open Multi-Decks (80" Height)

ORMC80(L/M)-PX: (L=Low, M=Medium Sill Height)-PX=Produce Exclusive

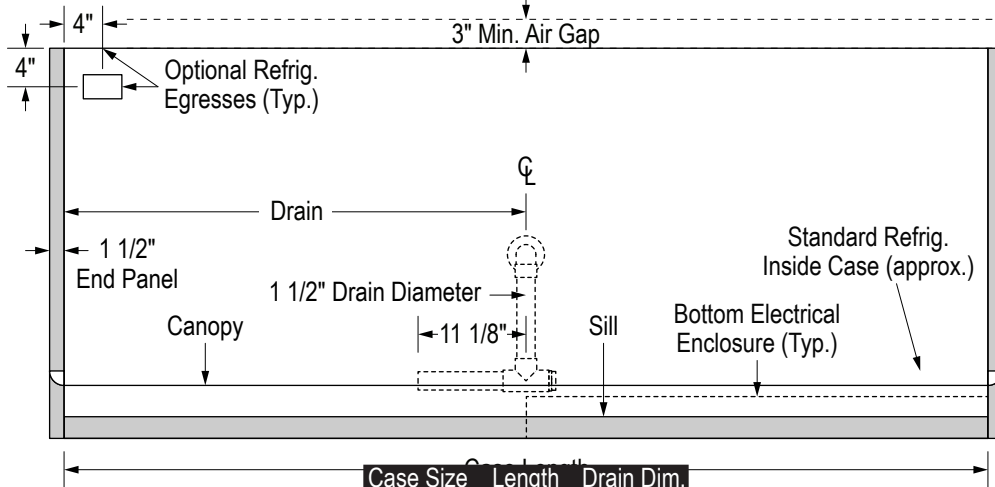

Case Size	Length	Drain Dim.
4'	48"	24"
6'	72"	36"
8'	96"	48"
12'	144"	72"

Top refrigeration connections increase case height by up to 4".

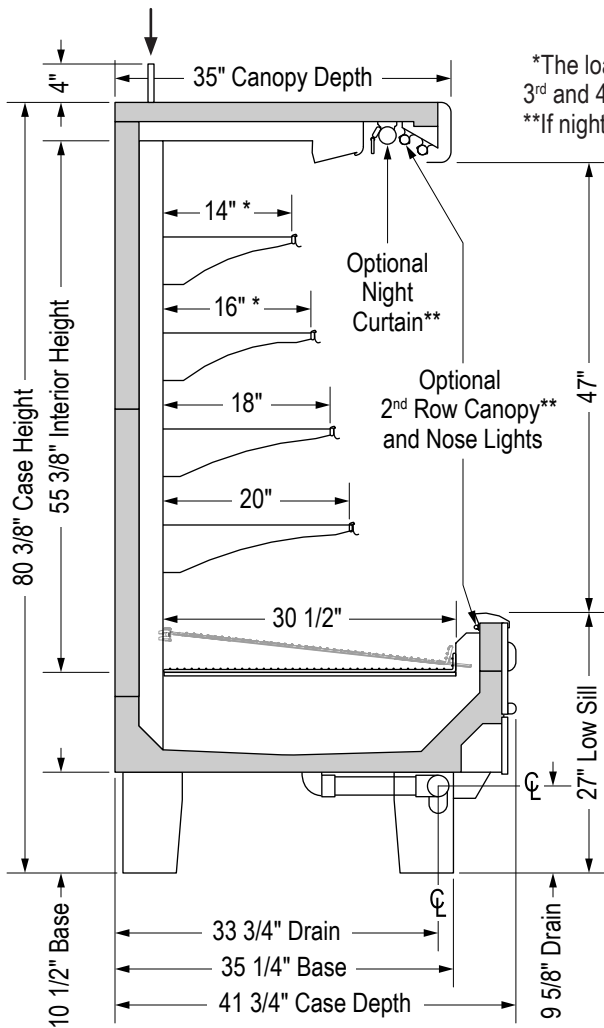

*The load limit affects maximum shelf depth. Max: Top shelf = 14"; 2nd shelf = 16"; 3rd and 4th shelf = 18".

**If night curtain is ordered, 2nd row of canopy lights are not available.

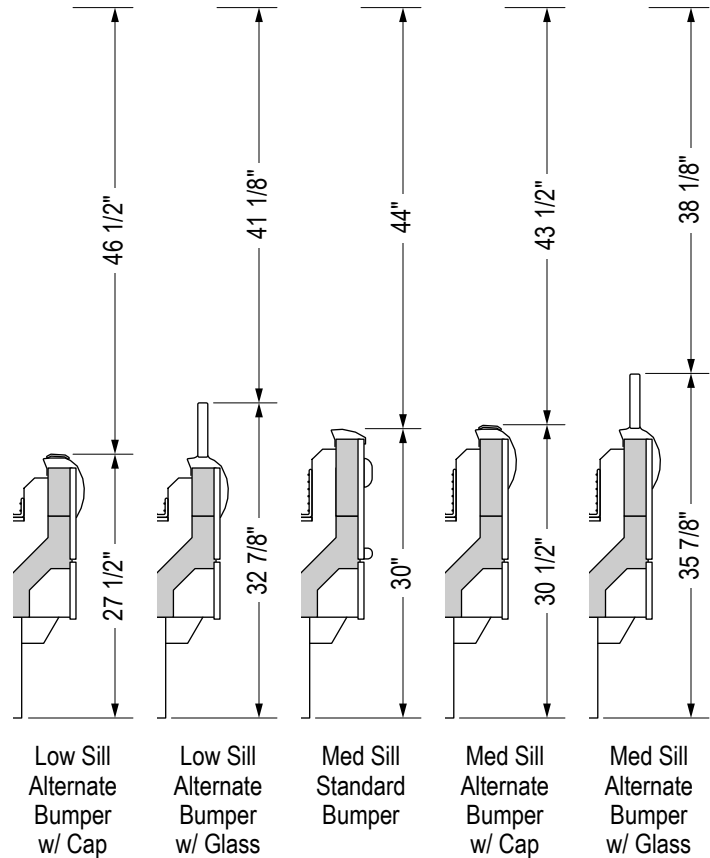

SS-95-G

Specifications are subject to change without notice. All dimensions are nominal.
Case designed to operate in an ambient temperature of 75°F and relative humidity of 55% or lower.

10/4/2023



Zero Zone, Inc.
800-247-4496 • www.zero-zone.com
© 2023 Zero Zone, Inc.





Reveal Merchandiser® ORMC82(L/M)-PX Specs

Open Multi-Decks (82" Height)

ORMC82(L/M)-PX: (L=Low, M=Medium Sill Height)-PX=Produce Exclusive

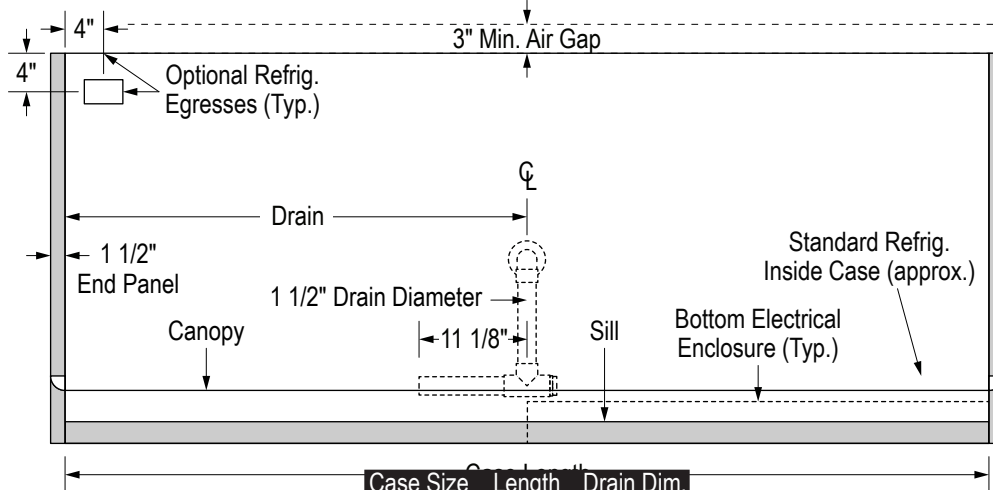

Case Size	Length	Drain Dim.
4'	48"	24"
6'	72"	36"
8'	96"	48"
12'	144"	72"

Top refrigeration connections increase case height by up to 4".

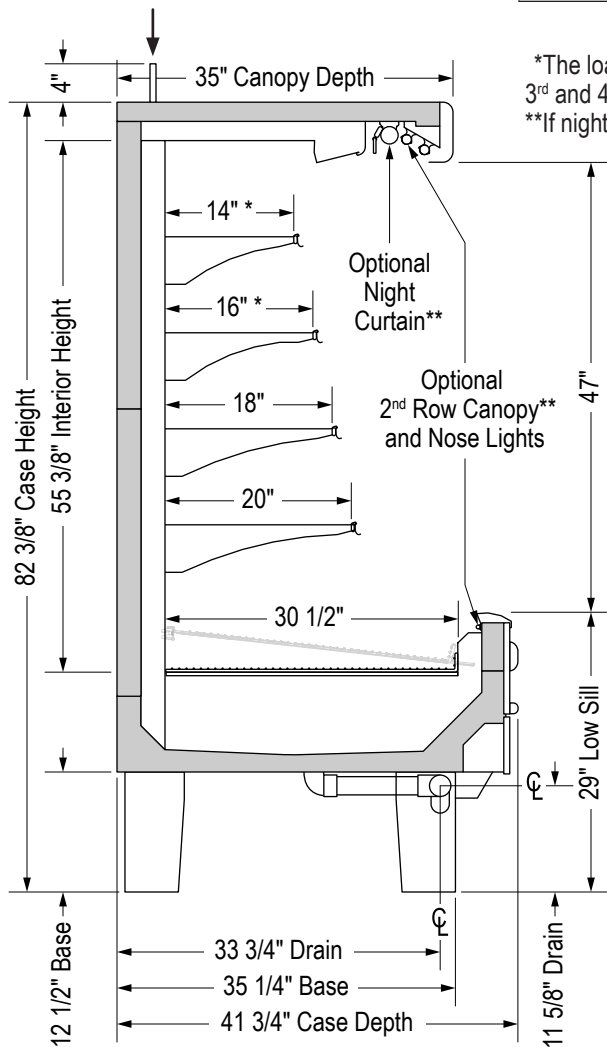

*The load limit affects maximum shelf depth. Max: Top shelf = 14"; 2nd shelf = 16"; 3rd and 4th shelf = 18".

**If night curtain is ordered, 2nd row of canopy lights are not available.

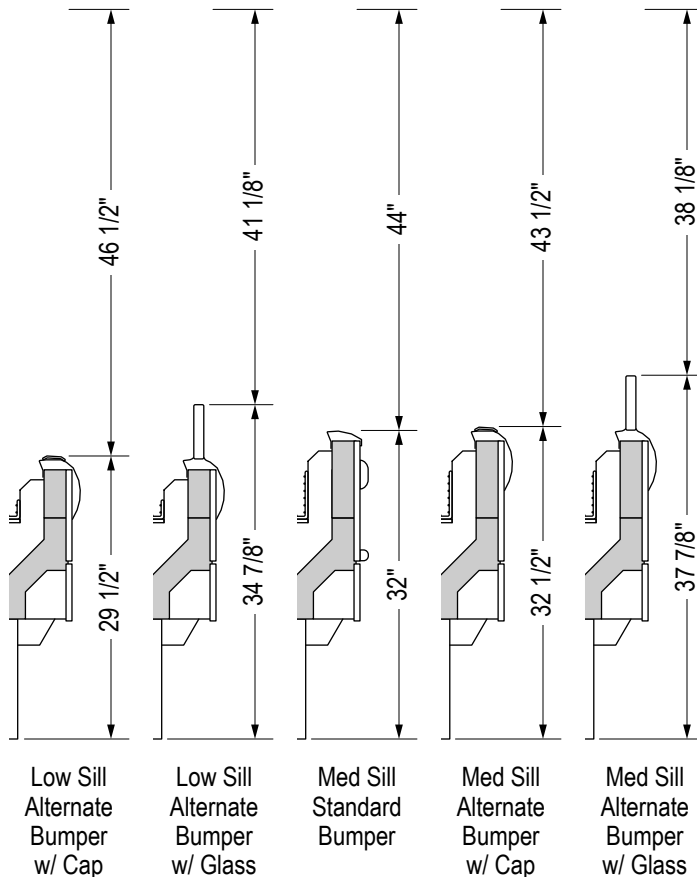

SS-95-G

Specifications are subject to change without notice. All dimensions are nominal.
Case designed to operate in an ambient temperature of 75°F and relative humidity of 55% or lower.

10/4/2023



Zero Zone, Inc.
800-247-4496 • www.zero-zone.com
© 2023 Zero Zone, Inc.

