



# Self-Contained Coolers

## INSTALLATION and OPERATING INSTRUCTIONS for

### SMCP26 Series



### SMCP26FL Series



### SMCP26PC Series





## TABLE OF CONTENTS

### SUBJECT

<b>GENERAL INFORMATION.....</b>	<b>1</b>
INTRODUCTION.....	1
INSPECTION.....	1
LOCATION.....	1
<b>INSTALLATION.....</b>	<b>1</b>
ELECTRICAL.....	1
START-UP.....	1
<b>USER INFORMATION.....</b>	<b>2</b>
CLEANING.....	2
SHELF LOCATION.....	2
LANE DIVIDERS – (SHELF ACCESSORIES).....	2
SHELF GLIDES – (SHELF ACCESSORIES).....	2
PRE CUT SALAD RACK – (SHELF ACCESSORIES).....	2-3
FLORAL SHELVES – (SHELF ACCESSORIES).....	3
TEMPERATURE CONTROL.....	3
LOADING THE COOLER.....	3
LIGHT SWITCH.....	3
COIL DE-ICING.....	3
<b>SERVICE.....</b>	<b>3</b>
EVAPORATOR.....	3-4
EXPANSION VALVE.....	4
EVAPORATOR FANS.....	4
LIGHTS.....	4
ALTERNATE LIGHTING – T-8.....	4
COMPRESSOR ACCESS PANEL (GRILL).....	4
COMPRESSOR.....	4
LIGHT BALLAST.....	5
SIGNAGE.....	5
CIRCUIT PROTECTION.....	5
<b>PREVENTATIVE MAINTENANCE.....</b>	<b>5</b>
<b>SPECIFICATION SHEET.....</b>	<b>6</b>
<b>WIRING DIAGRAMS.....</b>	<b>7-8</b>
<b>WARRANTY.....</b>	<b>9</b>



## GENERAL INFORMATION

### Introduction

The information contained in this manual pertains to Zero Zone 2- and 3-door self-contained coolers used for refrigerated food, pre-cut salads, or floral merchandising. Zero Zone has made every effort to produce refrigeration equipment of the highest quality using state of the art components and modern manufacturing techniques. Read these instructions carefully and completely before attempting to install Zero Zone equipment. Refer to all National, State, and local electrical, health and HVACR code requirements before installation. These display coolers are designed to operate in an air-conditioned environment where the air temperature is maintained at 75°F or lower and the relative humidity does not exceed 55%.

### Inspection

These display coolers were factory-tested, inspected and properly packed to ensure delivery in the best possible condition. The equipment should be checked for damage before and after unloading. It should be uncrated immediately after unloading and further checked for damage.

**ALL CLAIMS FOR DAMAGES MUST BE FILED WITH THE TRANSPORTATION COMPANY – NOT WITH ZERO ZONE. THE CARRIER WILL SUPPLY NECESSARY REPORT AND CLAIM FORMS.**

Once uncrated, verify that the available electrical supply corresponds with that specified on the cooler's rating plate. The rating plate can be found on the ceiling of the cooler above the left-hand door.

### Location

The Zero Zone upright reach-in coolers are ideal for remodels, end cap displays or wherever space is at a premium. These coolers must not be installed in a location where they would be exposed to the direct

rays of the sun or near a source of radiant heat. Locate on a floor with sufficient strength because if the building floor sags, the cooler doors could bind. The cooler must be level and plumb for proper operation.

A minimum of a 4" space between the back of the cooler and surrounding wall and shelving must be maintained for proper case airflow.

## INSTALLATION

### Electrical

The cooler lights, fans, door heaters, and compressor operate on 115 volt, 1 phase, 60 Hz. Wiring should be sized according to the amperage rating stamped on the nameplate, which is located on the ceiling of the left-hand door. The standard amperage rating is 20 amps for a 2-door and 25 amps for a 3-door.

All internal wiring has been completed at the factory. Two-door cases have a three-prong 20-amp 115-volt appliance cord. Three-door units have a three-prong 25-amp 115-volt power connection that is made to the leads in the back of the ballast box located in the right side of the compressor compartment. A three prong 20-amp appliance cord is optional on 3-door cases. The cord connected units should be plugged into a dedicated 20-amp outlet.

The 3-door units' fans, lights and anti-condensate heaters are protected by a 20-amp circuit breaker. The breaker is mounted in the electric box located in the front of the case behind the grill. When a cord is supplied, the unit does not have a 20-amp circuit breaker.

**Note:** All wiring installations must comply with the National Electrical Code and all local codes.

### Start-Up

For the 2-door cord connected units the on/off switch must be switched on after the cord is connected. The on/off switch is mounted on the



electric box located in the front of the case behind the grill. For the 3-door cooler, energizing the electric circuit will start the case.

## USER INFORMATION

### Cleaning

The cooler should be thoroughly cleaned before start-up and routinely thereafter to maintain a sanitary appearance. Use mild detergent and warm water (never an abrasive cleaner) to wipe out the inside of the cooler. Wash down all glass doors with a quality glass cleaner. The cooler will remain bright and sparkling with just a few minutes of cleaning each week.

**Note:** Do not use high-pressure water or steam to clean the interior.

### Shelf Location (See Specifications)

The shelves are adjustable in ½ inch increments and may be located in any position for best display. Due to the air discharge arrangement, it is suggested that the uppermost shelf be placed 10 to 11 inches down from the ceiling and the remaining shelves approximately 10-1/2 inches apart at the front of the cooler.

**BE SURE SHELF CLIPS OR BRACKETS ARE COMPLETELY SEATED BEFORE INSTALLING THE SHELF.**

### Lane Dividers – (Shelf Accessories)

Lane Dividers with 2-7/8 inch or 3-1/4 inch wide lanes are available for use on the shelves. The rear of the lane divider has the shelf hooks inset from the end. The rear of the shelf should be set lower than the front so that the shelf slants downward at the rear. The lane divider is installed by hooking the rear hooks under the large shelf wire. Flex the lane divider and hook the wire under the large front shelf wire (See Figure 1).

### Shelf Glides – (Shelf Accessories)

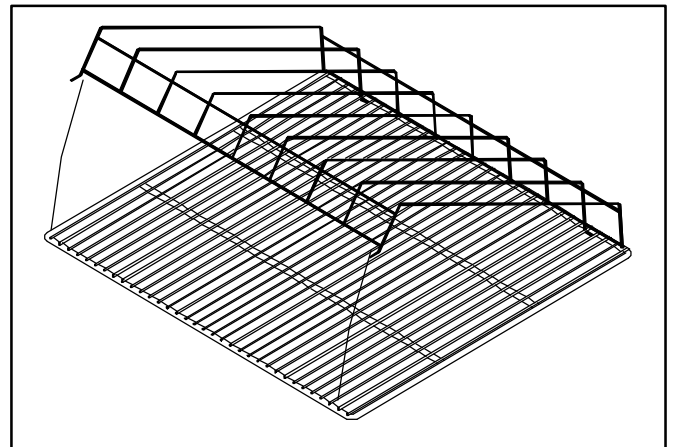

Figure 1. Lane Divider

Shelf glides are available for use with lane dividers. This helps the product gravity feed to the front of the case.

### Pre Cut Salad Rack – (Shelf Accessories)

The rear of the rack has two feet that slip under the shelf wires. The rear of the rack also has a raised wire stop. The stop is used to provide an air gap between the product and rear wall.

The rack is installed as follows:

- Set the rack on top of the shelf
- Rotate the rack 45 degrees to the side
- Slide both rear feet under the shelf wires

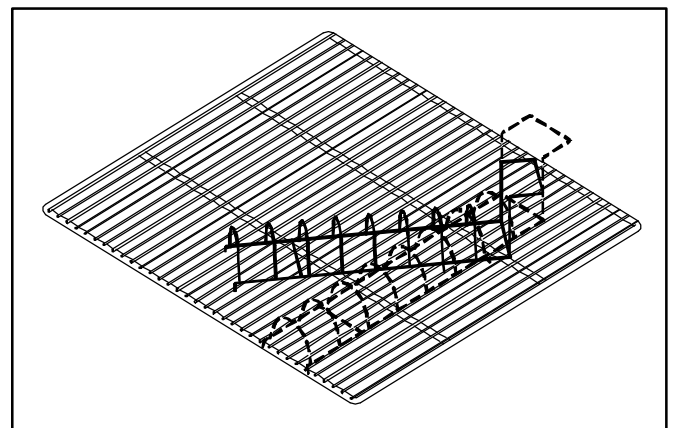

Figure 2. Salad Rack



- Rotate the salad rack back to the original position while keeping the rear feet under the wires
- Gently squeeze the front of the rack and slide the two feet between the shelf wires (See Figure 2)

### Floral Shelves – (Shelf Accessories)

Glass cantilever floral shelves are available. The shelves rest on special extra wide shelf brackets. Cantilever floral bucket shelves are also available. The bucket shelf bracket is adjustable to allow for shelf tilting. Before attempting to adjust the shelf bracket, follow these steps:

- Remove the shelf
- Remove the set screw from the side of the bracket
- Rotate the bracket to the new position
- Install the set screw
- Cantilever shelf standards are factory installed and must be ordered with a new case

### Temperature Control

The cooler temperature is controlled by a low-pressure control, located in the compressor compartment. The control is factory-set to maintain a cooler air temperature of 36°F to 41°F. An adjustment knob on top of the low-pressure control permits fine-tuning of the cooler temperature.

To raise the case temperature, turn the adjusting knob to a higher number. To lower the case temperature, turn the knob to a lower number. The factory-set position is at "5". Maximum cold is "1".

When properly adjusted the unit should not run continuously. Off cycle time allows the coil to de-ice automatically. If a coil freeze-up occurs, unsatisfactory cooler temperatures will result.

### Loading The Cooler

The cooler may be loaded with merchandise after the desired case temperature has been achieved. When loading the shelves, leave at least 1-1/2 inches between the top of the merchandise and the shelf immediately above it. This allows customers to

remove the product from the cooler easily. Leave a 1½-inch air gap at the rear of the case. This allows cool air to travel down the back of the product and return to the evaporator at the front of the case.

Products should be placed on the shelves in an orderly fashion. Whenever possible, leave some room between rows of packages so that chilled air can filter over and around products.

For proper display, the products should be placed on edge and slanted to the back so the customer can see the faces of the packages. Rotate inventory on a regular basis.

### Light Switch

The light switch is located inside the cooler in the upper right corner of the frame or on the mullion of the right door. Always turn the lights off when replacing bulbs.

### Coil De-Icing

Periodic de-icing to keep the coil free of excessive frost for top efficiency is accomplished automatically during the unit off cycle.

**! CAUTION !**

**ADJUSTING THE CASE TEMPERATURE TO AN EXTREMELY LOW SETTING WILL CAUSE THE UNIT TO RUN CONTINUOUSLY. IF THIS OCCURS, THE OFF-CYCLE DEFROST STAGE WILL NOT OCCUR, RESULTING IN UNSATISFACTORY COOLER OPERATION AND COIL ICING.**

### **SERVICE**

**! CAUTION !**

**DISCONNECT POWER TO THE CASE BEFORE SERVICING ELECTRICAL COMPONENTS.**



## Evaporator

The evaporator coil, located at the rear ceiling of the cooler, is factory assembled with an expansion valve. To inspect the coil, the coil cover can be removed as follows. Loosen screws on the underside of the coil cover until forward edge drops down exposing the evaporator coil and fan assemblies. While supporting the cover, unplug the fan electrical connection from main coil housing. The coil cover can then be removed from the case.

## Expansion Valve

A thermostatic expansion valve with adjustable super-heat and thermal bulb is mounted to the evaporator coil. Under certain conditions, it may be necessary to adjust the super-heat setting for maximum coil effectiveness. To adjust the expansion valve, remove the coil cover as described for evaporator inspection. Remove the cap from the bottom of the valve. When looking up the valve stem, turn the valve stem counter-clockwise to open the valve. Turn the valve stem clockwise to close the valve. Measure the suction line temperature at the expansion valve-sensing bulb and compare it to the suction temperature corresponding to the saturated pressure.

Turn the valve stem only  $\frac{1}{4}$  turn at a time and allow sufficient time for the valve to settle before making any further adjustments. Replace the valve stem cap after the valve super-heat has been adjusted.

## Evaporator Fans

Air is circulated throughout the cooler with shaft down, 115-volt medium temperature fan motors. These motors must be operating at all times. The fans are mounted on the evaporator coil cover. To service the fans, they are accessed by removal of the coil cover as described under SERVICE/EVAPORATOR.

## Lights

800 milliamp T-12 lamps are standard with these coolers. There are three lamps in the 2-door coolers and four lamps in the 3-door coolers. The full height lamps provide even illumination of the entire case contents for a better presentation. To ensure maximum component life, always replace with 800 milliamp lamps. Use retainer clips and lamp shields.

To change a lamp, turn off the light switch and remove the retainer clip located between the socket and end cap. Carefully push the lamp upward into the spring-loaded lamp socket to allow the lamp to be removed

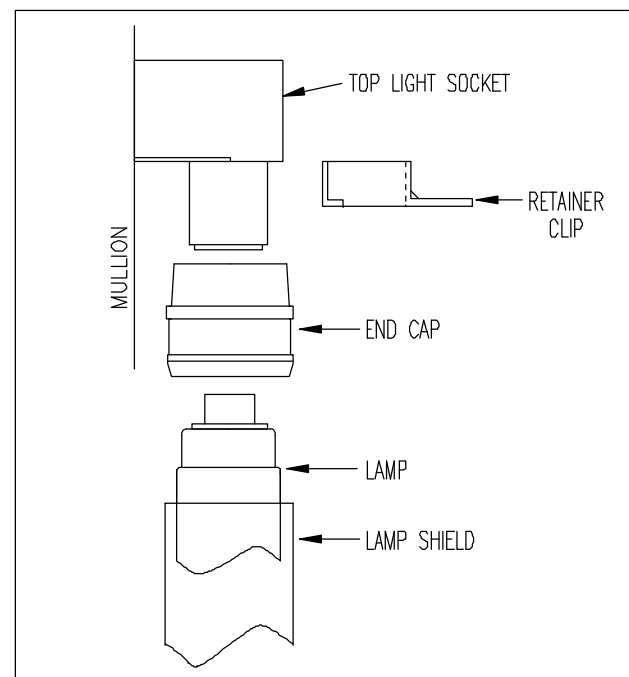

Figure 3. Changing A Light Bulb

from the bottom socket. (See Figure 3.) Remove the end caps and lamp shield for use on the new lamp.

## Alternate Lighting – T8

These systems use a lens to direct lamp light output evenly across the shelves. The bulb used is an Osram FO32W/41K (4ft). The lens must be removed to access the lamp. With the lens removed, reach into the fixture and remove the mylar warning cover. Remove the lamp socket assembly by carefully pulling away from the top and bottom retaining



clips. Move the foam center seals away from the electrical connectors. Disconnect the electrical connectors on the top and bottom sockets by depressing the locking tab and pulling away from the socket. Detailed information is contained in the door instruction booklet.

**Note:** The ballast for this system is located in the door mullion.

### Compressor Access Panel (Grill)

Remove the compressor access panel located at the front bottom of the cooler by removing the screws at the bottom ends of the panel. Drop the panel down and pull out. The panel must be removed before any service work can be done to the compressor, light ballasts and pressure control.

### Compressor

A 115 volt, 1 phase, 60 Hz, compressor is mounted below the cooler. The condensing unit is equipped with liquid line and suction service valves for refrigeration technician service.

### Light Ballast

The 2-door cooler has one (1) three-lamp ballast.

The 3-door cooler has two (2) two-lamp ballasts. They are located in the galvanized electric box located at the right side of the compressor compartment at the back.

To remove the electric box cover, remove the sheet metal screws from the bottom of the ballast box and slide the cover upwards to disengage the top flange. The cover can then be removed for ballast inspection or replacement.

### Circuit Protection

The 3-door unit is equipped with one 20-amp circuit breaker. The circuit breaker is located in the front of the electric box. The circuit breaker protects the fan, door and light circuits. If these circuits fail to work,

check to make sure the circuit breaker is switched to the "on" position. A red bar below the word "off" indicates the circuit breaker has tripped. To reset the breaker, switch it off and then on. If the circuit breaker continues to trip, contact a technician to repair the case.

### **PREVENTIVE MAINTENANCE**

1. Clean condenser fins at least once every 6 months in order to achieve maximum cooling efficiency. More often if cooler is in a particularly dirty or dusty location or near an entrance or check out.
2. Keep floor drain pan and condensate drain tube clear of debris.



# SMCP26 SPECIFICATION SHEET

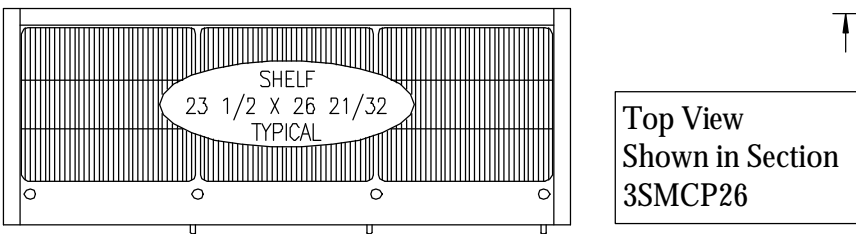
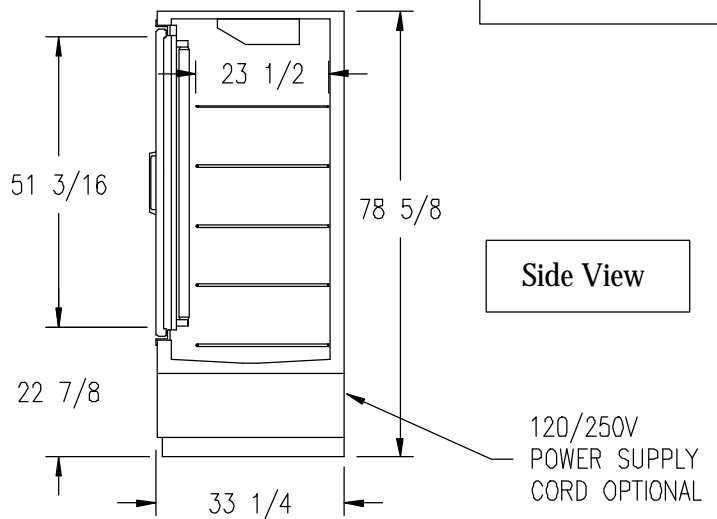
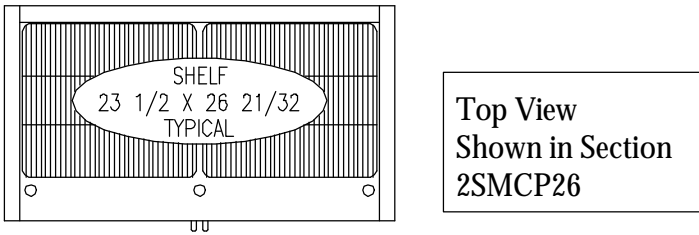
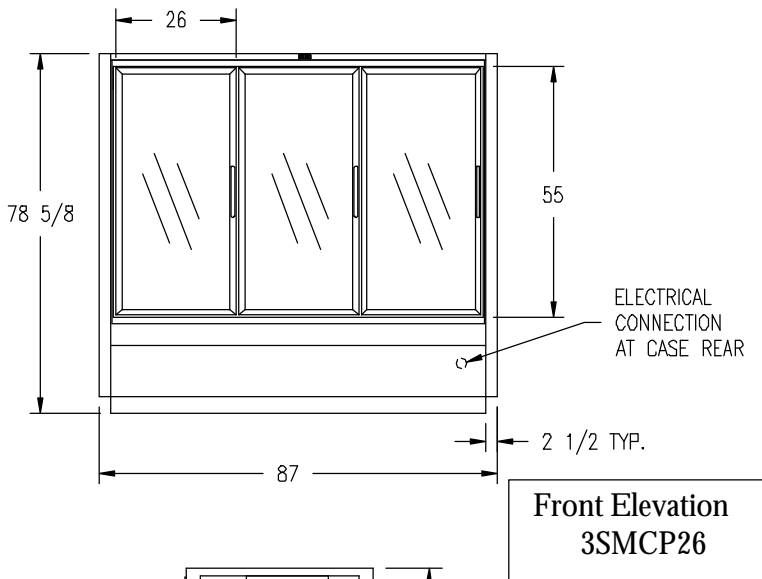
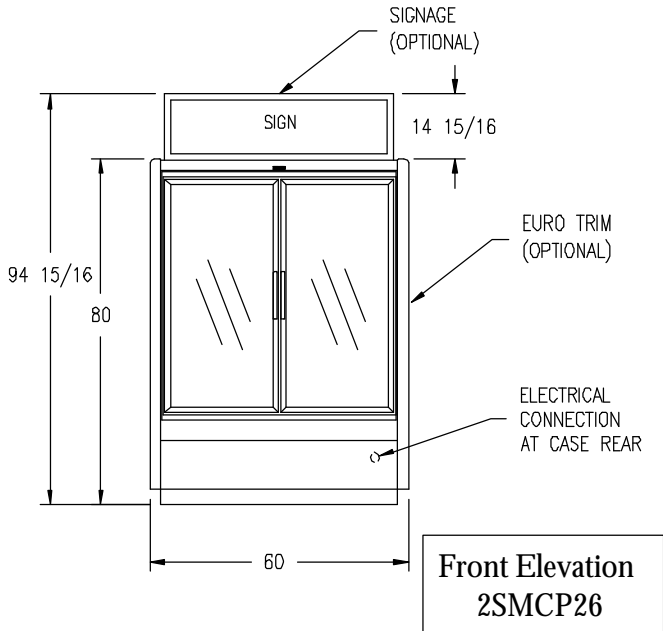

MODEL	WEIGHT (w/shelves)	OUTSIDE DIMENSIONS (INCHES)			INSIDE DIMENSIONS (INCHES)			NET CUBIC FEET CAPACITY	NET SHELF AREA SQ. FT.
		W	H	D	W	H	D		
2SMCP26	640	60	78 5/8	33 1/4	55	59 7/8	29 1/2	43.6	43.5
3SMCP26	856	87	78 5/8	33 1/4	82	59 7/8	29 1/2	61.4	65.3
MODEL	ELECTRICAL						H.P.	REF.	(OPTIONAL)
	INCOMING SUPPLY			MIN CIRCUIT AMPS	AMPS RLA	REF.			CHARGE (LBS.)
2SMCP26	115-1 PHASE-60 HZ.			20	14.02	1/2	R22	2 1/2	
3SMCP26	115-1 PHASE-60 HZ.			25	17.6	1/2	R22	2 1/2	

Zero Zone Inc. • 110 N. Oakridge Dr.  
 North Prairie, WI 53153-9792  
 1-800-247-4496 • FAX: 1-262-392-6450  
 www.zero-zone.com

All specifications are subject to change without notice.



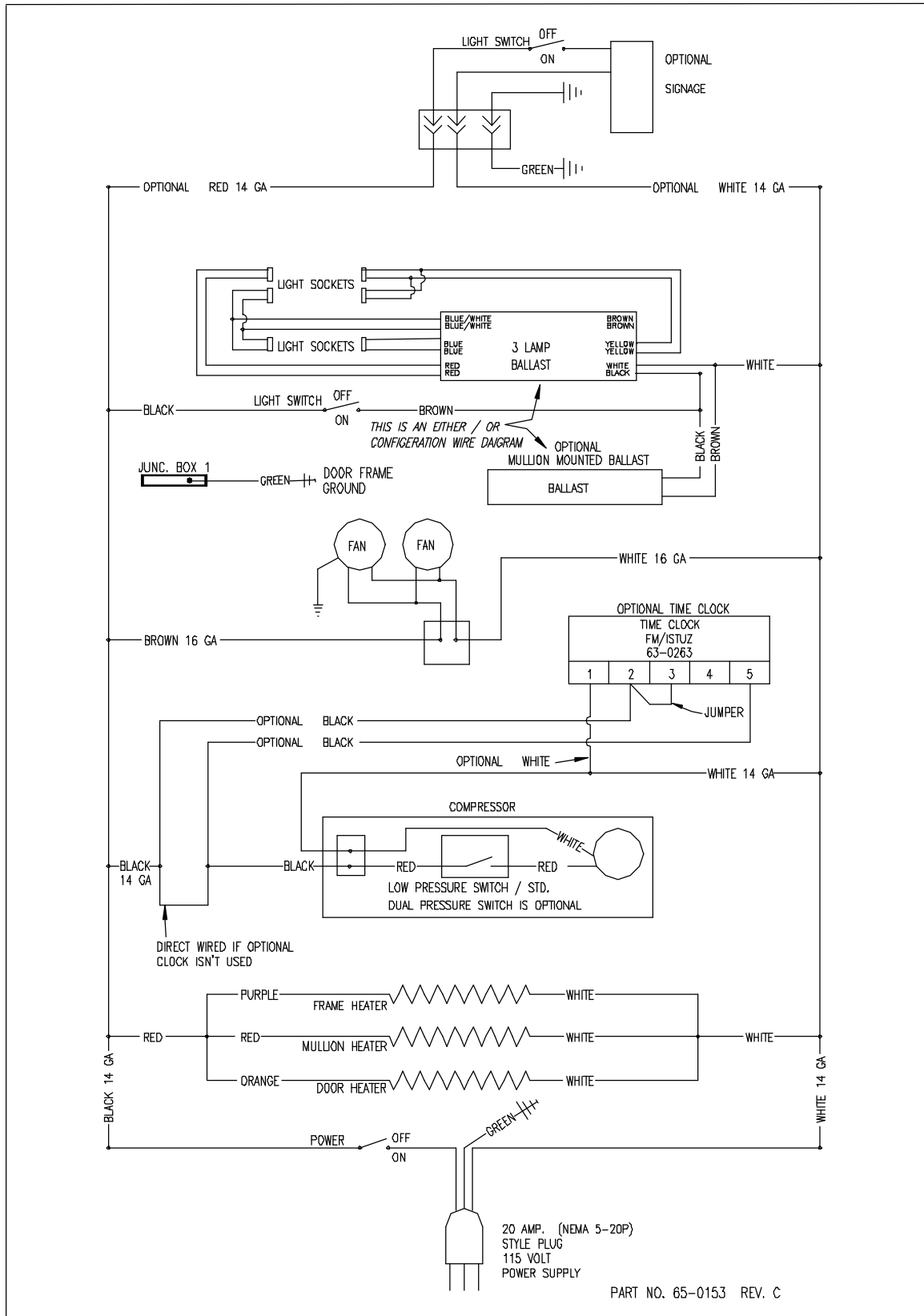

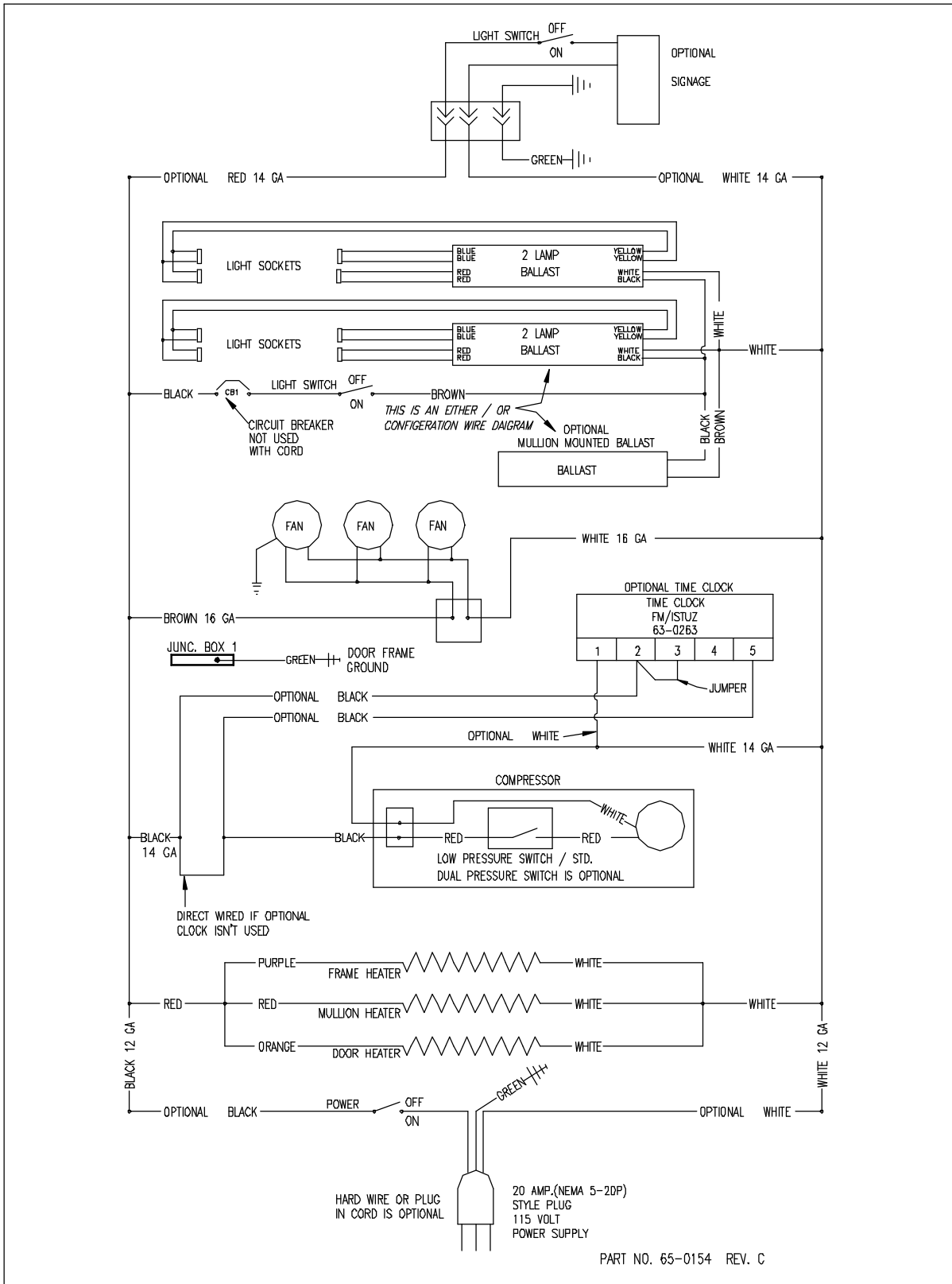



1. **Limited Warranty.** ZERO ZONE, INC. ("Seller") hereby warrants that any products manufactured by it and sold under this Warranty shall be free for a period of one year from the date of shipment, from defects in material and workmanship which, under normal use and service would render such products unusable or unserviceable. The obligation of Seller under this Warranty shall be limited to the repair or replacement of any parts that the Seller determines are defective. This Limited Warranty does not cover labor, freight, transportation or other charges incidental to replacement or repair. Parts returned to Seller must be returned freight prepaid and replacements will be returned to the Buyer freight collect.
2. **Motor Compressor Extended Warranty.** Seller hereby warrants with respect to any motor compressor sold under this Warranty, exclusive of any and all parts of the condensing unit assembly thereof, that such motor compressor shall be free from defects in material and workmanship for a period of four (4) years from the date of the expiration of the one year Warranty provided by the manufacturer of such motor compressor, **if the Buyer purchases said Warranty at the time of equipment purchase.** In the event the motor compressor is not free from defects in material and/or workmanship during such four year period, Buyer must purchase a replacement for the defective motor compressor and obtain whatever salvage credit may be available from the manufacturer thereof. Upon receipt by Seller or written notice from Buyer of compressor, Seller will issue a purchase or a refund, at Seller's option, for an amount of the salvage credit. All labor and shipping charges incurred in connection with such replacement shall be the sole obligation of the Buyer.
3. **Product Not Manufactured by Seller.** The written Warranty, if any, provided by the manufacturer of any part of the refrigeration unit sold by Seller to Buyer, but not manufactured by Seller, is hereby assigned to Buyer. However, Seller makes no representation or Warranty regarding the existence, validity or enforceability of any such written Warranty.
4. **LIMITATION AND EXCLUSION OF WARRANTIES.** THE WARRANTIES SET FORTH HEREIN ARE EXCLUSIVE AND IN LIEU OF ALL OTHER WARRANTIES AND REMEDIES WHATSOEVER, INCLUDING BUT NOT LIMITED TO, IMPLIED WARRANTIES OF MERCHANTABILITY AND/OR FITNESS FOR A PARTICULAR PURPOSE.
5. **Consequential Damages.** Notwithstanding anything to the contrary set forth in this Warranty Certificate, Seller shall not be liable for any incidental or consequential damages arising out of, or directly or indirectly caused by a defective part sold by Seller, including but not limited to, costs arising from the replacement of the part, loss of gas or product, or any damage to person or property, whether as a result of Seller's negligence, breach of contract, breach of Warranty or otherwise.

Model No. \_\_\_\_\_ Serial No. \_\_\_\_\_