



# Self-Contained Freezers

# INSTALLATION and OPERATING INSTRUCTIONS for

**SMZP26 Series**



Zero Zone, Inc. • 110 N. Oakridge Dr. • North Prairie, WI 53153-9792  
1-800-247-4496 • FAX: 1-414-392-6450 • [www.zero-zone.com](http://www.zero-zone.com)

CRMA  
Certified



06995M21000129

# TABLE OF CONTENTS



<b>SUBJECT</b>	
<b>GENERAL INFORMATION</b> .....	<b>1</b>
INTRODUCTION.....	1
INSPECTION.....	1
LOCATION.....	1
<b>INSTALLATION</b> .....	<b>1</b>
ELECTRICAL.....	1
START-UP.....	1-2
<b>USER INFORMATION</b> .....	<b>2</b>
	2
CLEANING.....	
SHELF LOCATION.....	2
TEMPERATURE CONTROL.....	2
LOADING THE FREEZER.....	2
LIGHT SWITCH.....	2
<b>DEFROSTING</b> .....	<b>3</b>
	3
GENERAL.....	
DEFROST TIME CLOCK.....	3
LIMIT THERMOSTAT.....	3
<b>SERVICE</b> .....	<b>3</b>
	3
EVAPORATOR.....	
EXPANSION	3
VALVE.....	
ELECTRIC DEFROST ELEMENT.....	4
EVAPORATOR FANS.....	4
LIGHTS.....	4
ALTERNATE LIGHTING – T-8.....	4
COMPRESSOR ACCESS PANEL (GRILL).....	4
	4
COMPRESSOR.....	
LIGHT BALLAST.....	5
ELECTRICAL COMPONENTS.....	5
REFRIGERATION	5
COMPONENTS.....	
CONDENSATE DRAIN PAN HEATER.....	5
<b>PREVENTATIVE MAINTENANCE</b> .....	<b>5</b>
<b>SPECIFICATION SHEET</b> .....	<b>6</b>
<b>WIRING DIAGRAMS</b> .....	<b>7-8</b>





## GENERAL INFORMATION

### Introduction

The information contained in this manual pertains to Zero Zone 2- and 3-door self-contained freezers used for frozen food or ice cream merchandising. Zero Zone has made every effort to produce refrigeration equipment of the highest quality using state of the art components and modern manufacturing techniques.

Read these instructions carefully and completely before attempting to install Zero Zone equipment. Refer to all National, State, and local electrical, health and HVACR code requirements before installation.

These display freezers are designed to operate in an air-conditioned environment where the air temperature is maintained at 75°F or lower and the relative humidity does not exceed 55%.

### Inspection

These display freezers were factory-tested, inspected and properly packed to ensure delivery in the best possible condition. This equipment should be checked for damage immediately upon delivery, both before and after. **ALL CLAIMS FOR DAMAGES MUST BE FILED WITH THE TRANSPORTATION COMPANY – NOT WITH ZERO ZONE.** The carrier will supply necessary report and claim forms.

### Location

The freezer must not be installed in the direct rays of the sun or near a source of radiant heat. It must be installed on a sound floor of sufficient strength and must be level and plumb for proper operation.

A minimum 4" space between the back of the freezer and the building wall or shelving must be maintained for proper airflow.

## INSTALLATION

### Electrical

The freezer lights, fans, and door heaters operate on 115 volt, 1 phase, 60 Hz. The compressor and defrost heater operate on 208/230 volt, 1 phase, 60 Hz.

All internal wiring has been completed at the factory. The 115-208/230 volt power connections are made to the leads protruding from the left side of the electrical box, which is located on the right side of the compressor compartment.

A cord connection is optional on the 2-door case. When a cord is supplied, a NEMA 14-20R four prong 20 amp twist lock receptacle must be provided in your store. The cord length is approximately 6 feet.

A four-wire 115-208/230 volt single-phase circuit is required for both case sizes. Wiring should be sized according to the amperage rating stamped on the serial plate. A standard 2-door case is rated at 20 amps. A standard 3-door case is rated at 25 amps.

Note: all wiring must comply with the National Electrical Code and all local codes.

### Start-up

Make sure the compressor floats free on the mounting grommet. The case is shipped with the valves back seated (open).

Energizing the electric circuit will start the case. On cord-connected units, the on/off switch must be switched on after the cord is connected. The on/off switch is mounted on the electric box located in the front of the case behind the grill. After the case is in operation, set the Time Clock to the proper time of day so that defrost will occur at the desired time.

To set the Time Clock, remove the front grill and locate the display on the face of the electrical box. Flip up the plastic bezel face of the display to reveal four keypad buttons.



1. Press and hold SET for 5 seconds. The display will show CloC.
  2. Press SET again to change the time of day.
  3. Press up or down until the correct time-of-day is displayed.
  4. Press SET to accept the change.
  5. Press the down arrow twice to exit the menu.
- See page 8 of the ERC2 manual for more details.

Note: When the freezer is started from an ambient condition, the lights and fans may not immediately turn on. They will turn on and off until the coil temperature reaches a stable 25°F or lower. The limit control regulates the operation of the fans and lights. Refer to defrosting section for complete details.

## **USER INFORMATION**

### Cleaning

The freezer should be thoroughly cleaned before start-up, and routinely thereafter to maintain a clean appearance. Use mild detergent and warm water (never an abrasive cleaner) to wipe the inside of the freezer. Wash down all glass doors with a good glass cleaner. The freezer will remain bright and sparkling with just a few minutes of cleaning each week.

**Note: Do not use high-pressure water or steam to clean the interior. Remove any debris to prevent the drain tube from clogging.**

### Shelf Location (See Specifications)

The shelves are adjustable in ½ inch increments and may be located in any position for best display advantage due to the air discharge arrangement. It is suggested that the uppermost shelf be placed 10 to 11 inches down from the ceiling and the remaining shelves approximately 10 inches apart at the front of the freezer.

### Temperature Control

An electronic time clock is used to regulate temperatures in the freezer. A temperature probe located in the return air sends temperature information to the control. The control is factory-set to maintain a freezer air temperature of -8°F to -16°F. The control is mounted in the control panel box located at the right front of the compressor compartment.

To adjust the temperature, remove the front grill and locate the display on the face of the electrical box. Flip up the plastic bezel face of the display to reveal four keypad buttons.

6. Press and hold SET for 5 seconds. The display will show CloC.
  7. Press the down arrow and the display will show SET.
  8. Press up or down to go to the desired setpoint temperature.
  9. Press SET to accept the change.
  10. Press the down arrow to exit the menu.
- See page 8 of the ERC2 manual for more details.

### Loading The Freezer

The freezer may be loaded with merchandise after it has been operating for at least 12 hours with correct case temperature and proper control operation. While loading the shelves, **leave at least 1-1/2" between the top of the merchandise and the shelf immediately above it** so the customer can reach to select the merchandise. This space also helps in maintaining proper airflow in the freezer.

### Light Switch

The light switch is located inside the freezer in the right door opening. Always turn the lights off when replacing lamps.



## DEFROSTING

### General

Periodic defrosting to keep the coil free of excessive frost for top efficiency is accomplished automatically by the control system. A time clock is used to defrost the freezer coil at predetermined times during the day.

### Defrost Time Clock

The defrost sequence of operation is as follows:

When the control system initiates a defrost cycle, the fans, door heaters and compressor are turned off. The defrost heater is energized and defrosting begins. As the ice on the coil melts, the temperature in the coil rises to the set point. When the set point is reached, the defrost is terminated. If the coil temperature fails to reach the termination temperature but the fail-safe time has elapsed, the control system will terminate the defrost.

In either case, normal freezer operation is resumed.

DEFROST FACTORY SET POINTS	
NUMBER/DAY	2
TERMINATION	48 ° F
FAIL SAFE	50 MIN.
DEFROST TIME	8 am & 8 pm

Adjustments can be made to the number of defrosts, termination temperature or time, and time of each defrost. See page 9 and 10 of the ERC manual for instructions.

### Limit Thermostat

Each freezer has a factory set limit thermostat to regulate the operation of the evaporator fans, and door heaters. The thermostat is built into the electronic control.

BECAUSE OF THE LIMIT THERMOSTAT, THE EVAPORATOR FANS AND DOOR HEATERS WILL REMAIN OFF UNTIL THE COMPRESSOR IS OPERATING

AND THE COIL TEMPERATURE IS BROUGHT BELOW THE THERMOSTAT CUT-IN SETTING (+25°F.).

When the freezer first operates (due to temperature fluctuations), the fans may cycle off and on a few times until coil temperature is below +25°F.

## SERVICE

**! CAUTION !**  
**DISCONNECT POWER TO THE CASE BEFORE**  
**SERVICING ELECTRICAL COMPONENTS.**

### Evaporator

The evaporator coil is located at the bottom rear of the freezer under a two-piece metal cover. To inspect the coil, remove the sheet metal screws from the cover and back wall. The shorter cover on the right side must be removed first.

### Expansion Valve

A thermostatic expansion valve with pressure limiting ZP charge, adjustable super-heat and sensing bulb is mounted to the evaporator outlet. Under certain conditions, it may be necessary to adjust the super-heat setting for maximum coil effectiveness. To adjust the expansion valve, remove the right end coil cover from the top end of the coil. Remove the cap from the valve. When looking at the valve stem, turn it counterclockwise to open the valve. Turn the valve stem clockwise to close the valve. Measure the suction line temperature at the expansion valve-sensing bulb and compare it to the suction temperature corresponding to the saturated pressure.

Turn the valve stem only ¼ turn at a time and allow sufficient time for the valve to settle before making any further adjustments. Replace the valve stem cap after the valve super-heat has been adjusted.  
**BE CERTAIN THE VALVE STEM CAP IS WIPED DRY.**

## Electric Defrost Element

The defrost element is located under the evaporator coil. The electric wire leads are connected in the electrical box located on the right side of the compressor compartment. To remove the defrost element, remove the coil covers. Take out the two sheet metal screws in front of the heater tray. These screws are located one on each end of the evaporator coil. Then slide out the complete heater pan assembly from under the coil and under the fan housing. Slowly lift the heater pan assembly between coil and fan housing, turning it on edge while lifting.

## Evaporator Fans

Air is circulated throughout the freezer with shaft up, 115-volt low temperature fan motors. These motors must be operating at all times except during defrost. To service the fan:

1. Disconnect all power.
2. Remove wire fan guard and the two mounting bracket screws.
3. Unplug fan from fan power supply plug located under fan housing.

## Lights

High output 1500 milliamp bulbs are standard with these freezers. To ensure maximum component life, always replace with 1500 milliamp bulbs. Use retainer clips and lamp shields.

To change a light bulb, turn off the light switch and remove the retainer clip located between the socket and the end cap. Carefully lift the lamp up into the spring-loaded lamp socket to allow the bulb to be removed from the bottom socket. (See Figure 1.) Remove the end caps and lamp shield.

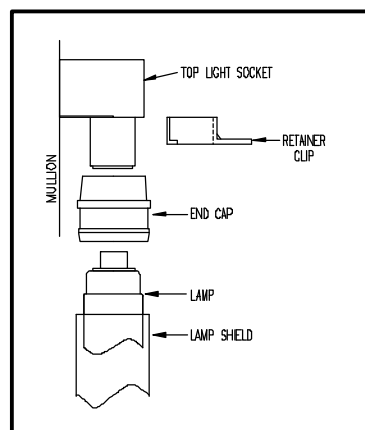

## Alternate lighting – T8

These systems use a lens to direct light output evenly across the shelves. The bulb used is an Osram FO32W/41K (4ft). The lens must be removed to access the bulb. With the lens removed, reach into the fixture and remove the mylar warning cover. Remove the bulb/socket assembly by carefully pulling away from the top and bottom retaining clips. Move the foam center seals away from the electrical connectors. Disconnect the electrical connectors on the top and bottom sockets by depressing the locking tab and pulling away from the socket. Detailed information is contained in the door instruction booklet.

## Compressor Access Panel (Grill)

The compressor access panel (grill) is located at the front bottom of the freezer. It can be taken off by removing the two screws at the bottom ends of the panel. Drop the panel down and pull the bottom of the grill outward. The panel must be removed before any service work can be done to the compressor, electronic control system or condensate drain pan heater.

## Compressor

A 208/230v, 1 phase, 60 Hz, R404A/R507 (prior to 1/95 R502) compressor is mounted in the compressor compartment located below the freezer. The condensing unit is equipped with a liquid receiver, and suction service valves for the refrigeration technician.

R404A is the standard refrigerant. Check your nameplate to determine if R507 was supplied as a special order.



## Light Ballast

The 3-door freezer has two (2) two-lamp ballasts. They are located in the galvanized electric box on the right side of the compressor compartment.

The 2-door freezer has one (1) three-lamp ballast. It is located in the galvanized electric box located on the right side of the compressor compartment.

If the case is equipped with T-8 lighting, the ballasts are mounted in the door frame mullions.

## Electrical Components

To remove the electric box cover, remove the 4 sheet metal screws from the face of the electric box. The cover can then be removed for component inspection or replacement.

The ERC-2 display is attached to the box cover, connecting the box to the cover. Slowly remove cover to prevent damage to cable or connector sockets.

## Refrigeration Components

Whenever refrigeration components have been replaced, the low side should be pressurized and the connections checked for leaks. Evacuate the low side to remove moisture and non-condensables that may have been introduced during the service process. After leak check and evacuation, all of the service valves should be opened to put the system into operation. A certified refrigerant technician must do this work.

## Condensate Drain Pan Heater

To replace the pan heater, disconnect the power supply to case. Remove the electrical box access panel. Heater wire connections are on the terminal block mounted in the electrical box.

## PREVENTIVE MAINTENANCE

1. Clean condenser fins at least once every month, more often if freezer is in a dusty location.
2. Keep floor drain pan and drain tube clear of debris.
3. Clean condensate drain pan periodically.





# SMZP26 SPECIFICATION SHEET

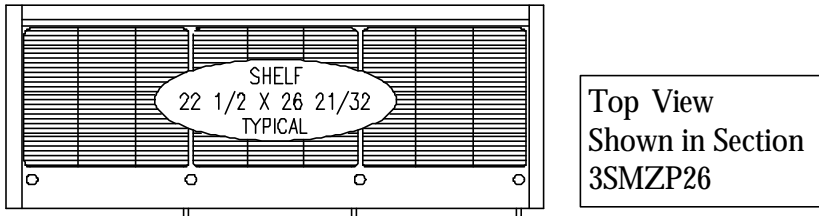
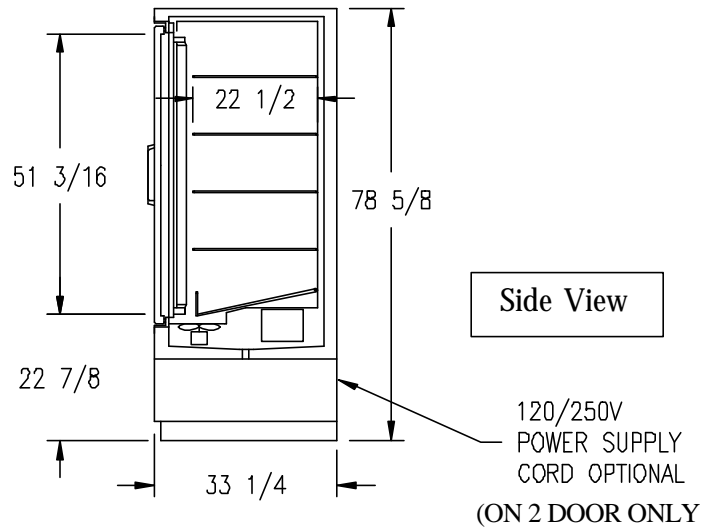
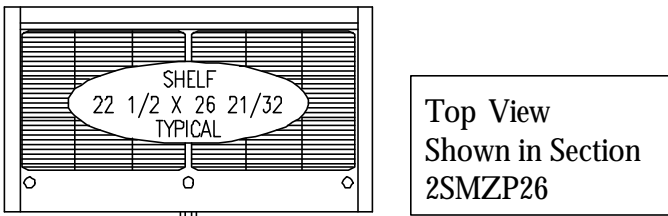
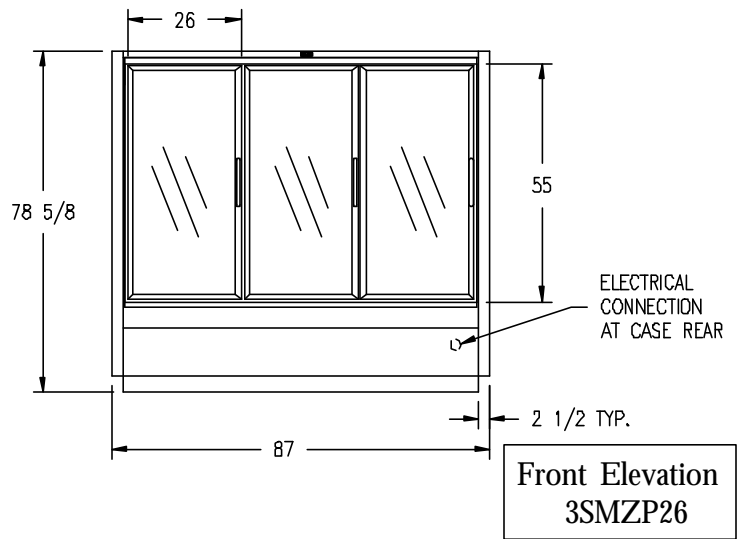
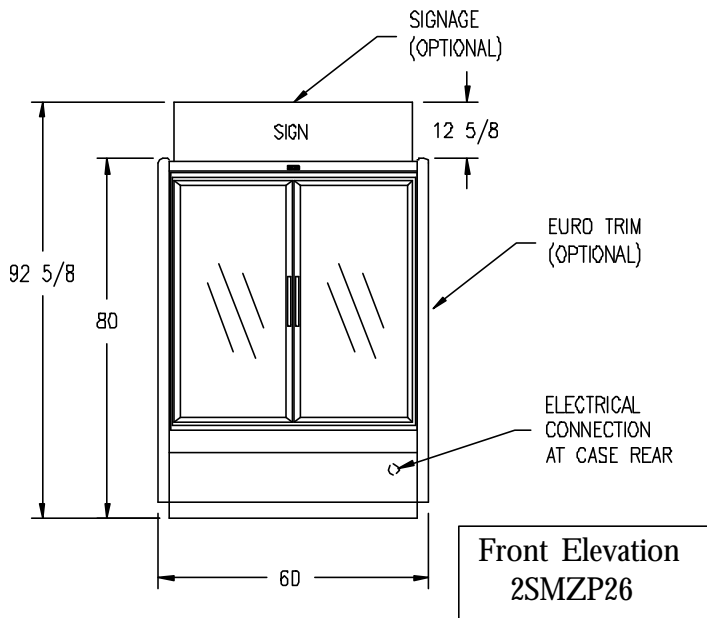

MODEL	WEIGHT (w/shelves)	OUTSIDE DIMENSIONS (INCHES)			INSIDE DIMENSIONS (INCHES)			NET CUBIC FEET CAPACITY	NET SHELF AREA SQ. FT.
		W	H	D	W	H	D		
2SMZP26	866	60	78 5/8	33 1/4	55	52	28 3/8	37.2	41.7
3SMZP26	1108	87	78 5/8	33 1/4	82	52	28 3/8	55.5	62.5

MODEL	ELECTRICAL				H.P.	REF.	CHARGE (LBS.)
	INCOMING SUPPLY		MIN CIRCUIT AMPS	AMPS RLA			
2SMZP26	115-208/230V-1 PHASE-60 HZ.		20	16	1 1/2	R404A	4 1/2
3SMZP26	115-208/230V-1 PHASE-60 HZ.		25	19	2	R404A	5 1/2

Zero Zone Inc. • 110 N. Oakridge Dr.  
 North Prairie, WI 53153-9792  
 1-800-247-4496 • FAX: 1-262-392-6450  
[www.zero-zone.com](http://www.zero-zone.com)

All specifications are subject to change without notice.



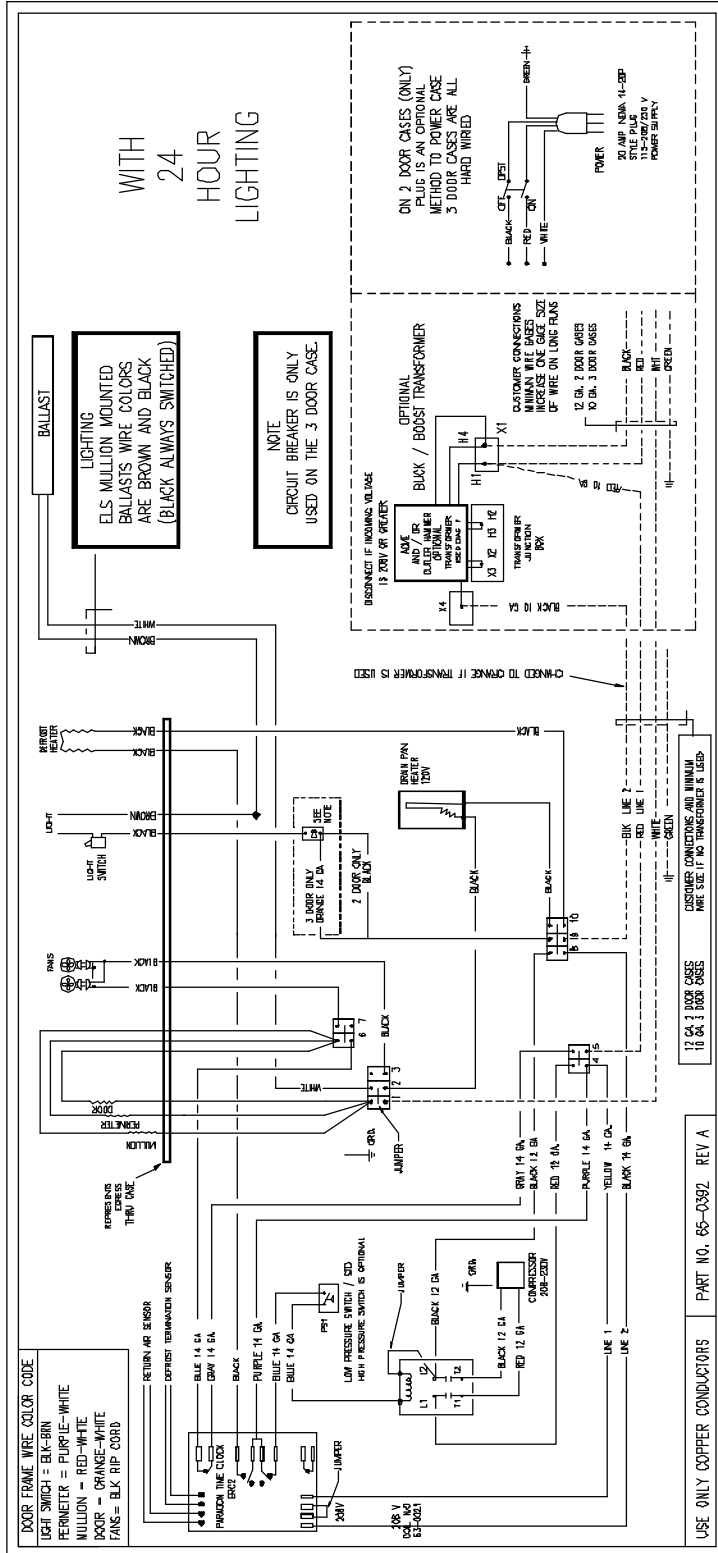

### WIRING FOR 2SMZP26 W/24 HOUR LIGHTING